

PART V
GRAPTOLITHINA
WITH SECTIONS ON ENTEROPNEUSTA
AND PTEROBRANCHIA

By O. M. B. BULMAN

CONTENTS

	PAGE
INTRODUCTION	V3
General features of graptolites	V4
Outline of classification	V4
Suprageneric divisions of Graptolithina and other classes of Stomochorda	V4
Morphological terms applied to Graptolithina and other Stomochorda	V5
Glossary of morphological terms	V5
ENTEROPNEUSTA AND PTEROBRANCHIA	V7
Stomochorda	V7
Subphylum Stomochorda Dawydoff, 1948	V7
Enteropneusta	V8
Class Enteropneusta Gegenbaur, 1870	V8
Pterobranchia	V8
Class Pterobranchia Lankester, 1877	V8
Morphology	V8
Order Rhabdopleurida Fowler, 1892	V9
Order Cephalodiscida Fowler, 1892	V11
GRAPTOLITHINA	V12
Diagnosis and general features	V12
Class Graptolithina Bronn, 1846	V12
Previous studies	V12
Techniques	V13
Preparation of specimens	V13
Illustration	V14
Mode of life	V15
Significance of graptolitic facies	V16
Distribution	V17
Geographical distribution	V17
Geological distribution	V17
Sources for correlation of graptolite zones	V18
Graptolite affinities	V18
Nature of graptolite zooid	V20
Dendroidea	V21

(V1)

	PAGE
Order Dendroidea Nicholson, 1872	V21
Morphology	V21
Periderm	V22
Thecae	V23
Stolothecae	V23
Autothecae	V24
Bithecae	V25
Thecal grouping	V25
Mode of branching	V26
Dissepiments	V27
Development	V28
Classification	V29
Systematic descriptions	V30
Tuboidea	V37
Order Tuboidea Kozłowski, 1938	V37
Camaroidea	V41
Order Camaroidea Kozłowski, 1938	V41
Morphology	V41
Systematic descriptions	V42
Stolonoidea	V42
Order Stolonoidea Kozłowski, 1938	V42
Morphology	V42
Systematic descriptions	V43
Graptoloidea	V43
Order Graptoloidea Lapworth, 1875	V43
Morphology	V43
General features	V43
Periderm	V44
Sicula	V44
Thecae	V45
General relations	V45
Interthecal septa	V46
Principal types	V46
Monograptid trends and their significance	V49
Thecal spines	V50
Common canal	V51
Nema or virgula	V51
Branching of rhabdosome	V52
Median septum	V52
Localized thickening	V53
Muscle scars	V54
Regeneration	V54
Development	V54
General discussion	V54

	PAGE
Dichograptid type	V57
Isograptid type	V58
Leptograptid type	V58
Diplograptid type	V59
Other biserial types	V61
Monograptid type	V63
Graptogonophores	V63
Cladia	V64
Synrhabdosomes	V66
Evolutionary trends and faunal succession	V67
Dichograptid fauna	V68
Leptograptid fauna	V68
Diplograptid fauna	V68
Monograptid fauna	V68
Classification	V69
Principles	V69
Phylogeny	V69
Systematic descriptions	V74
Graptolithina incertae sedis	V94
Group Graptovermida Kozłowski, 1949	V94
Group Graptoblasti Kozłowski, 1949	V94
Group Acanthastida Kozłowski, 1949	V94
Unrecognizable genera	V95
REFERENCES	V95
SOURCES OF ILLUSTRATIONS	V98
INDEX	V99

INTRODUCTION

Several attempts have been made in the past to produce a comprehensive textbook (as opposed to a monograph) dealing with the graptolites, although they are generally regarded as a "difficult" group of animals whose study is best left to the few specialists. BARRANDE's *Graptolites de Bohême* (1850) perhaps may be claimed as an essay in this direction; HALL's *Introduction to the Study of the Graptolites* (1869), essentially a reprint of the lengthy introduction to his *Graptolites of the Quebec Group*, is a still better example; and Part I (all that was ever published) of Nicholson's *Monograph of British Graptolitidae* (1872) also deals at length with generalities of structure, development, and distribution, with a description of then-recognized genera. After this, there was a long interval when prog-

ress was measured in the appearance of a succession of national monographs (mainly at specific level), although accounts of these organisms were included in various textbooks, of which FRECH's account in ROEMER's *Lethaea Palaeozoica* (1897) and RUEDEMANN's contribution to ZITTEL-EASTMAN's *Textbook* (1912) are the best-known. In 1938, the present writer prepared a section on Graptolithina for SCHINDEWOLF's *Handbuch der Paläozoologie*, but unfortunately the greater part of the impression was destroyed during the war. Despite the barren war years so much has happened since that writing to extend our knowledge of the nature and structure of graptolites that the present volume had to be rewritten entirely. That this too rapidly will become out of date in consequence of work now in

progress in many different countries seems inevitable, but such activity is a welcome indication of revived interest in the group.

It is a pleasure to acknowledge the editorial assistance of Professor RAYMOND C. MOORE, and the help of several of my

students and co-workers who have given me information in advance of their own publications. The section on "Mode of Life" has been taken largely from the *Treatise on Ecology*.

GENERAL FEATURES OF GRAPTOLITES

This section of the *Treatise* is concerned primarily with the Graptolithina, but it is prefaced with a short account of living and fossil Stomochorda (*Balanoglossus*, *Cephalodiscus*, and *Rhabdopleura*). The reason for this is that although the graptolites are an extinct group, confined to the Paleozoic, recent morphological discoveries have made it seem probable that they may be allied more nearly to some of the Stomochorda than to any other living group, and accordingly they are here provisionally regarded as a separate class of that subphylum.

The graptolites are colonial organisms that secrete an external skeleton of chitinous material.¹ This skeleton has the form of a cup or tube (*theca*) surrounding each individual zooid, the thecae being assembled along one or more branches (*stipes*) to form the complete colony or *rhabdosome*. When flattened and carbonized, the stipes commonly present the appearance of a minute saw, being of about the same scale of magnitude as a fretsaw blade. The colony originates in a conical cell (*sicula*) differing

from the subsequently formed thecae in various points of morphology, and contrasting in its comparative uniformity with the variety to be found in thecal form. The sicular individual probably differs in character from the later zooids which bud from it (p. V21).

In several orders, the budding process is related to a chitinized stolon reminiscent of the *pectocaulus* of *Rhabdopleura*, and the structure and histology of the periderm also are closely similar to those of the pterobranchiates. These are the principal features supporting attribution of the graptolites to the Stomochorda.

Graptolite remains are widely distributed in rocks of Paleozoic age, particularly the lower Paleozoic, where the members of one order (Graptoloidea) have an acknowledged value in stratigraphical correlation. The other (sessile) orders have a sporadic distribution and little stratigraphical value. Remains of true pterobranchs are excessively rare; apart from one Tremadocian genus, a few species assigned to *Cephalodiscus* and *Rhabdopleura* have been described from upper Mesozoic and Tertiary strata.

¹The use of the terms "chitin" and "chitinous" here and in following pages does not imply an exact knowledge of the substance of the graptolite periderm; its histology is described on page V22.

OUTLINE OF CLASSIFICATION

For convenience of reference, it seems desirable to furnish a tabular summary of suprageneric taxonomic assemblages which are recognized and described in this division (Part V) of the *Treatise* and to place it near the beginning of the text. The known stratigraphic range of each unit is stated and the number of recognized genera is indicated by accompanying figures enclosed in parentheses; where genera and subgenera are recorded, both are enumerated, the first figure given referring to genera and the second to subgenera.

Suprageneric Divisions of Graptolithina and Other Classes of Stomochorda

- Stomochorda (*subphylum*) M.Cam.-Rec.
- Enteropneusta (*class*) Rec.
- Pterobranchia (*class*) (4;4) L.Ord.-Rec.
- Rhabdopleurida (*order*) (1) Cret.-Rec.
- Rhabdopleuridae (1) Cret.-Rec.
- Cephalodiscida (*order*) (3;4) L.Ord.(Tremadoc.)-Rec.
- Eocephalodiscidae (1) L.Ord.(Tremadoc.).
- Cephalodiscidae (2;4) ?Eoc., Rec.
- Graptolithina (*class*) (127) Cam.-L.Carb.
- Dendroidea (*order*) (34) Cam.-L.Carb.
- Dendrograptidae (11) U.Cam.-L.Carb.
- Anisograptidae (7) L.Ord.(incl.Tremadoc.).
- Acanthograptidae (3) ?U.Cam., M.Ord.-U.Sil.
- Inocaulidae (4) Ord.-Sil.

- Ptilograptidae (1) *L.Ord.(Arenig.)-U.Sil.*
 Chaunograptidae (4) *Cam.-Dev.*
 Incertae sedis (4) *Ord.-Sil.*
 Tuboidea (order) (11) *L.Ord.(Tremadoc.)-Sil.*
 Tubidendridae (1) *L.Ord.(Tremadoc.)*.
 Idirotubidae (10) *L.Ord.(Tremadoc.)-Sil.*
 Camaroidea (order) (5) *L.Ord.(Tremadoc.)*
 Bithecocarididae (1) *L.Ord.(Tremadoc.)*.
 Cysticamaridae (4) *L.Ord.(Tremadoc.)*.
 Stolonioidea (order) (1) *L.Ord.(Tremadoc.)*
 Stolonodendridae (1) *L.Ord.(Tremadoc.)*.
 Graptoloidea (order) (76) *L.Ord.-U.Sil.*
 Dichograptidae (28) *L.Ord.-M.Ord.*
 Multiramous forms (16) *L.Ord.*
 Goniograpti (8) *L.Ord.(Arenig.-Llanvirn.)*.
 Temnograpti (2) *L.Ord.(Arenig.)*.
 Schizograpti (5) *L.Ord.*
 Dichograpti (1) *L.Ord.(Arenig.-Llanvirn.)*.
 Pauciramous forms (12) *L.Ord.-M.Ord.*
 Tetragrapti (2) *L.Ord.*
 Didymograpti (10) *L.Ord.(Tremadoc.)-M.*
 Ord.
 Corynoididae (1) *M.Ord.*
 Cryptograptidae (4) *L.Ord.-M.Ord.*
 Leptograptidae (5) *M.Ord.-U.Ord.*
 Dicranograptidae (2) *M.Ord.-U.Ord.*
 Diplograptidae (10) *L.Ord.-L.Sil.*
 Climacograptinae (1) *L.Ord.-L.Sil.*
 Diplograptinae (4) *L.Ord.-L.Sil.*
 Petalograptinae (2) *L.Sil.*
 Incertae sedis (3) *L.Ord.-U.Ord.*
 Lasiograptidae (4) *Ord.*
 Retiolitidae (12) *M.Ord.-U.Sil.*
 Archiretiolitinae (4) *M.Ord.-U.Ord.*
 Retiolitinae (3) *L.Sil.*
 Plectograptinae (5) *M.Ord.-U.Sil.*
 Dimorphograptidae (3) *L.Sil.*
 Monograptidae (7) *L.Sil.-U.Sil.*
 Monograptinae (2) *L.Sil.-U.Sil.*
 Cyrtograptinae (5) *M.Sil.-U.Sil.*
 Incertae sedis (5) *Ord.*
 Graptovermida (group) (2) *Ord.*
 Graptoblasti (group) (2) *L.Ord.(Tremadoc.)*
 Acanthastida (group) (1) *L.Ord.(Tremadoc.)*.

MORPHOLOGICAL TERMS APPLIED TO GRAPTOLITHINA AND OTHER STOMOCHORDA

Description of the morphology of various-rank divisions of the Stomochorda recognized in this book is given in several places under appropriate headings. Accordingly, it has seemed very desirable to organize a single alphabetically arranged glossary of morphological terms containing concise definitions and indicating typographically the relative importance attached to the different terms. Thus, most commonly used terms are printed in boldface capital letters (as **AUTOTHECA**), useful but less important terms in boldface small letters (as **clathria**), and least important (in part obsolete) terms in italic letters (as *solid axis*).

Glossary of Morphological Terms

anastomosis. Temporary fusion, as of adjacent branches to form an ovoid mesh.

ancora (ancora stage). Anchor-shaped initial growth stage of retiolitids, apparently formed of virgella with 2 distal bifurcations.

appendix. Reticulate tubular structure at distal end of rhabdosome in certain Plectograptinae.

AUTOTHECA. One of the 3 types of graptolithine thecae, possibly containing female zooid (*see stolotheca*).

basal disc. See root.

biform. Graptoloid rhabdosome (esp. Monograptidae) with thecae of 2 conspicuously different shapes.

bilateral. Graptoloid rhabdosome disposed more or less symmetrically to right and left of sicula.

BISERIAL. Scandent graptoloid rhabdosome composed of 2 rows of thecae in contact back to back or side by side.

BITHECA. One of the 3 types of graptolithine thecae, possibly containing male zooid.

branch. See stipe.

branching, dichotomous. Division of stipe characterized by branches that diverge symmetrically from parent stipe.

branching, lateral. Division of stipe characterized by branch that diverges at an angle to parent stipe, which continues in its original direction of growth.

budding individual. Term previously used for stolotheca (obsolete).

camara. Proximal inflated portion of autotheca in Camaroidea.

central disc. Web of chitinous material uniting proximal ends of stipes in certain horizontal graptoloid rhabdosomes.

cladium. Rhabdosome or "pseudobranch" developed from thecal or sicular aperture in Cyrtograptinae, remaining attached to parent rhabdosome.

clathria. Skeletal framework of chitinous rods (lists), some supporting an attenuated periderm.

coenocidium. Chitinous exoskeleton of colonies or associations of Pterobranchia.

collum. Erect tubular portion of autotheca in Camaroidea.

colony. See rhabdosome.

COMMON CANAL. Tubular cavity lying along dorsal side of a stipe, formed by sum of the common portions of all thecae; approximately the sum of all prothecae along a stipe (Figs. 30,33).

corona. Inflated reticulate proximal end of retiolitids, succeeding the ancora stage in development. cortical tissue. *See* periderm.

CROSSING CANAL. Proximal (prothecal) portion of graptoloid theca which grows across axis of the sicula to develop on the side opposite that of its origin.

declined. Graptoloid rhabdosome with branches hanging below the sicula, subtending an angle less than 180° between their ventral sides (Fig. 28).

deflexed. Similar to declined but with distal extremities of stipes tending to horizontal (Fig. 28).

dendroid (habit of growth). Bushy colony formed by irregular branching.

denticulate (especially of thecae). Sharply pointed, provided with a short spine or mucro.

dichotomous. *See* branching.

dissepiment. Strand of periderm serving to connect adjacent branches in a dendroid rhabdosome (especially *Dictyonema*).

distal. Last-formed portion (of rhabdosome, theca, etc.) farthest away from point of origin (*see* proximal).

DORSAL. Side of uniserial stipe opposite thecal apertures, or comparable side of thecal aperture; in a horizontal dichograptid, for example, this is the dorsal side of rhabdosome in position of growth, but orientation is different in monograptids.

extensiform. Didymograptid with horizontal branches.

extroverted. Thecae hooked or turned back upon themselves by excessive growth of dorsal margin of aperture.

flabellate (habit of growth). Colony fan-shaped, with branches spread out in single plane.

fusellar tissue. *See* periderm.

gonangia. Term formerly used for bithecae (obsolete).

gymnocaulus. Unchitinized stolon behind terminal bud from which new zooids are proliferated (*Rhabdopleura*).

horizontal. Graptoloid rhabdosome with branches disposed in a plane at right angles to axis of sicula (Fig. 28).

hydrosome. Term formerly used for rhabdosome (obsolete).

hydrotheca. Term formerly used for autotheca of dendroids and theca of graptoloids (obsolete).

INITIAL BUD. Bud which grows out through foramen in sicular wall to produce first theca of rhabdosome; first stolothea in dendroids, prothecal portion of first theca in graptoloids.

intertecal septum. Chitinous membrane separating adjacent thecal cavities in Graptoloidea; generally

partly secreted by each of the 2 thecal zooids which it separates.

introverted. Theca turned inward (or dorsally) by excessive growth of ventral margin of aperture, usually accompanied by sigmoidal curvature of thecal axis.

isolation. Separation of distal extremities (meta-thecal portions) of adjacent thecae, as in *Rastrites*.

lacinia. Delicate chitinous network, extraneous to rhabdosome proper, supported on thecal, mesial, or septal spines.

languette. Laterally expanded ventral process of a theca.

lappet. Expanded lateral process of a theca.

list. Chitinous rod strengthening periderm, or (in form of clathria) supporting the reticula.

LOPHOPORE. Pair or group of fleshy "arms" provided with ciliated tentacles and situated adjacent to mouth of the zooid.

mesial. Middle portion of free ventral wall of a theca.

METASICULA. Distal part of sicula bearing normal graptolite growth lines (*see* sicula).

METATHECA. Distal portion of a graptoloid theca; equivalent to autotheca of dendroids (Fig. 30).

multiramous. With numerous branches.

NEMA. Hollow threadlike prolongation of apex of prosicula by which rhabdosome was attached; used where nema is "exposed," as in all except scandent rhabdosomes (*see* virgula).

OBVERSE. Aspect of rhabdosome in which sicula is most completely visible, opposite of reverse.

occlusion. Sealing of thecal aperture by a film of chitinous tissue.

orders (of branching). Successive divisions of dichotomous or lateral branches, or successive generations of cladia.

pauciramous. With comparatively few branches.

pectocaulus. Chitinized stolon (or "black stolon") embedded in lower surface of mature parts of coenocium of *Rhabdopleura*.

pendent. With branches hanging below sicula and approximately parallel (Fig. 28).

PERIDERM. Chitinous substance composing rhabdosome, consisting of an inner layer (fusellar tissue) with growth bands and growth lines, and an outer layer (cortical tissue) of laminated material.

polymorphic. Colony comprising more than one kind of zooid, or rhabdosome with more than one type of theca.

PROSICULA. Proximal, initially formed part of sicula, secreted as single conical unit (*see* sicula).

PROTHECA. Proximal portion of graptoloid theca before differentiation of the succeeding theca;

equivalent to stolothea of dendroids (Figs. 8, 30).

proximal. First-formed portion (of rhabdosome, theca, etc.) nearest to point of origin (*see* distal).

quadrilateral. Scandent graptoloid rhabdosome composed of 4 rows of thecae (*Phyllograptus*).

reclined. Graptoloid rhabdosome with branches growing upward, subtending an angle less than 180° between their dorsal sides (Fig. 28).

reflexed. Similar to reclined, but with distal extremities of the stipes tending to horizontal (Fig. 28).

reticula. Delicate chitinous network, usually supported on clathria (Retiolitidae).

REVERSE. Aspect of rhabdosome in which sicula is more or less concealed by crossing canal(s), opposite of obverse.

RHABDOSOME. Chitinous exoskeleton of graptolithine colony; compound or multiple rhabdosomes result from development of cladia, as in Cyrtograptinae (*see* synrhabdosome).

root. Basal discoidal plate or branching filamentous structure developed from sicula for attachment of sessile graptolites, as in Dendroidea.

SCANDENT. Graptoloid with stipes growing erect along or enclosing nema (=virgula); monograptid, biserial, or quadrilateral.

scopulae. Peculiar ramifying fibrous development from edges of median septum (as in lasiograptids) comparable with lacinia.

selvage. Thickened margin, especially of aperture.

septal. Related to septum.

SEPTUM. Chitinous membrane separating the 2 series of thecae in a biserial graptoloid, complete septum beginning between 4th formed theca (*th2*²) and 5th formed theca (*th3*¹), incomplete septum beginning between some later thecal pair, and partial septum occurring on one side (obverse or reverse) of rhabdosome only.

SICULA. Skeleton of initial zooid of a colony, divisible into a conical prosicula (secreted as one unit) and a distal metasicula (with normal graptolite growth lines).

solid axis. Term formerly used for virgula (obsolete).

STIPE. One branch of a branched rhabdosome; entire colony of an unbranched rhabdosome.

stolon. Slender internal chitinous thread (as in Dendroidea) from which thecae appear to originate; comparable with pectocaulus of Pterobranchia.

STOLOTHECA. One of the 3 types of graptolithine thecae, enclosing main stolon and proximal portions of daughter stolothea, autothea and bitheca; probably secreted by immature autothecal zooid, constituting in effect proximal portion of autothea (and equivalent to prothea of graptoloids).

synrhabdosome. Growth association of (usually) biserial graptoloid rhabdosomes attached distally by their nemata around a common center.

THECA. Chitinous tube or cup lodging any zooid of a rhabdosome; term very generally used to denote autothecae of Graptoloidea (which are not polymorphic).

thecal grouping. More or less regular association of groups of autothecae and bithecae to form small branches (twigs), particularly in Acanthograptidae.

thecorhiza. Encrusting basal disc in Tuboidea containing stolothecae, from which autothecae and bithecae arise singly, in clusters, or as branches.

twig. *See* thecal grouping.

UNISERIAL. Rhabdosome or stipe of graptoloid consisting of a single chain of thecae.

VENTRAL. Side of stipe on which thecal apertures are situated (*see* dorsal).

VIRGELLA. Spine developed during formation of metasicula, embedded in sicula wall and projecting freely from apertural margin.

VIRGULA. Hollow threadlike prolongation of apex of prosicula; homologous with nema, and used where this thread is enclosed within scandent rhabdosome (biserial rhabdosomes) or incorporated in dorsal wall (Monograptidae).

Wiman rule. Regular production of autothea, bitheca and stolothea in successive generations of alternating triads as first described by WIMAN; diagnostic of Dendroidea.

ZOOID. Soft-bodied individual inhabiting a theca or coenocelial tube.

ENTEROPNEUSTA AND PTEROBRANCHIA

STOMOCHORDA

Subphylum STOMOCHORDA

Dawydoff, 1948

Bilateral coelomate organisms with body divisible into 3 segments (protosoma, mesosoma, and metasoma), with mouth ventrally placed between protosoma and mesosoma, and diverticulum of dorsal part of pharynx

extending forward to form stomochord (comparable with notochord of the Chordata); posterior part of pharynx communicating with exterior by branchial pores. Nervous system primitive, but notoneural. *L.Ord.(Tremadoc.)-Rec.*

These organisms in the past have been

associated generally with the Urochorda (Tunicates) and Cephalochorda (*Amphioxus*) under the term Protochordates; but despite resemblances in the branchial and nervous systems, the difference between the stomochord (both in its origin and rela-

tions) and the notochord of true Chordata warrants their separation as a distinct group. They are here provisionally classed as a subphylum of the Chordata, but considerable doubt exists as to their true genetic affinities.

ENTEROPNEUSTA

Class ENTEROPNEUSTA Gegen- baur, 1870

[*nom. correct.* HAECKEL, 1879 (*pro* Enteropneusti GEGENBAUR, 1870)] [=Hemichorda BATESON, 1885]

Free, with elongate wormlike body and pronounced division into an acorn-shaped proboscis (protosoma), collar (mesosoma), and trunk (metasoma); stomochord extending into the proboscis; branchial apparatus well developed as a long double row of pores strengthened by a cuticular branchial skeleton. *Rec.*

The class is unknown fossil; among numerous living genera, the following may be mentioned:

Balanoglossus DELLE CHIAJE, 1829 [**B. clavigerus*]. Widely distributed around Atlantic and Pacific coasts.

Ptychodera ESCHSCHOLTZ, 1825 [**P. flava*]. Indo-Pac.-W. Indies.

Saccoglossus SCHIMKEWITSCH, 1892 [**Balanoglossus mereschkowskii* WAGNER, 1885]. N. Atl.-White Sea-Japan-N.Z.—FIG. 1. *Saccoglossus pusillus* RITTER, White Sea; $\times 0.7$ (11).

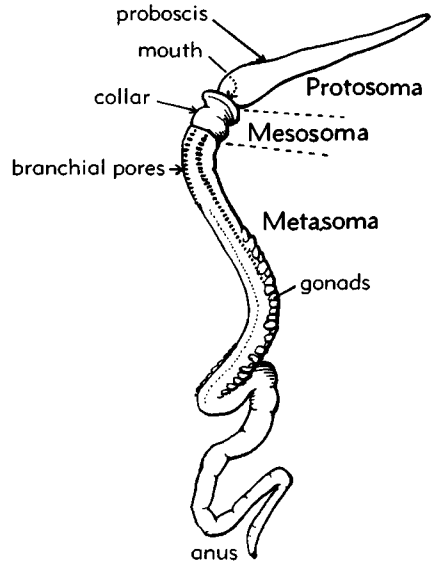

FIG. 1. A typical enteropneustan, *Saccoglossus pusillus*, showing the principal external features of the body (11).

PTEROBRANCHIA

Class PTEROBRANCHIA Lankester, 1877

Fixed colonial or pseudocolonial organisms; body compact and without conspicuous division into 3 parts; middle segment (mesosoma) small but with one or more pairs of arms furnished with tentacles (=lophophore); posterior segment (metasoma) with long stalk or peduncle by which the zooid may be attached; branchial apparatus rudimentary; cuticular skeleton external. *Cret.-Rec.*

MORPHOLOGY

The body of pterobranchiates is small (2 to 7 mm. in *Cephalodiscus*) or even microscopic (less than 0.5 mm. in *Rhabdopleura*), and its most conspicuous feature

is the lophophore structure developed from the mesosomal or collar segment, which gives it a pronounced bilateral symmetry and a superficially polyzoan appearance (Fig. 2,1). The lophophore consists of one pair of arms in *Rhabdopleura*, and many pairs in *Cephalodiscus*, and contains an extension of the collar coelom into the arms and tentacles. The preoral lobe (protosoma) forms a glandular cephalic disc which posteriorly overhangs the mouth. Only in embryonic stages is the mesosomal segment clearly differentiated from the trunk segment, and from the ventral side of the sac-like trunk arises the peduncle or contractile stalk. In *Rhabdopleura* this is of considerable length and serves to attach the organism at the base of its tube to the pectocaulus or stolon; it is shorter in *Cephalodiscus* and

free, the organisms living not in true colonies but in associations.

The mouth opens into a large pharyngeal region, from the roof of which is given off anteriorly a small diverticulum which is the homologue of the stomochord of the Enteropneusta; but in the pterobranchiates it does not extend forward into the protosomal segment. Laterally the pharynx is developed into a branchial region with a single pair of branchial pores in *Cephalodiscus*, whereas in *Rhabdopleura* the whole branchial structure is rudimentary. Posteriorly, the pharynx leads into a capacious stomach, from which a straight intestine doubles back to the anal pore situated on a dorsal prominence in the front part of the trunk segment. The gonads are paired in *Cephalodiscus*, single in *Rhabdopleura*; the sexes are separate except in certain species of *Cephalodiscus* where hermaphrodite individuals occur. Males and females usually are indistinguishable, but some species are dimorphic and in *C. sibogae* the males are degenerate. Asexual reproduction (budding) is common in both genera.

The blood system comprises few main vessels, centered on a cardiopericardial vesicle situated in the protosoma near the tip of the stomochord; this is claimed to be homologous with the madreporic vesicle of

larval echinoderms. The nervous system is rudimentary, with a central ganglion near the base of the lophophore.

A chitinous exoskeleton is secreted both by *Cephalodiscus* and *Rhabdopleura*.

Order RHABDOPLEURIDA

Fowler, 1892

Truly colonial animals with zooids attached by a contractile stalk to the stolon or pectocaulus; zooids provided with one pair of arms; gonads unpaired; no branchial pores. The skeleton (coenocidium) consists of an irregularly branching system of chitinous tubes, attached to the surface of a pebble or shell, from which slender free zooidal tubes rise erect. Creeping and zooidal tubes are alike composed of regular growth bands that are clearly defined by transverse growth lines, and the pectocaulus is embedded in the base of the creeping tube. *Cret.-Rec.*

Growth of the colony is by distal extension of the soft stolon (gymnocaulus) bearing at its extremity a permanent terminal bud ("blastozoid *inachevé*"). This terminal bud secretes the adnate or creeping tube as it advances. According to SCHEPOTIEFF, this tube is a closed, pointed tube; but LANKESTER describes it as an open-ended

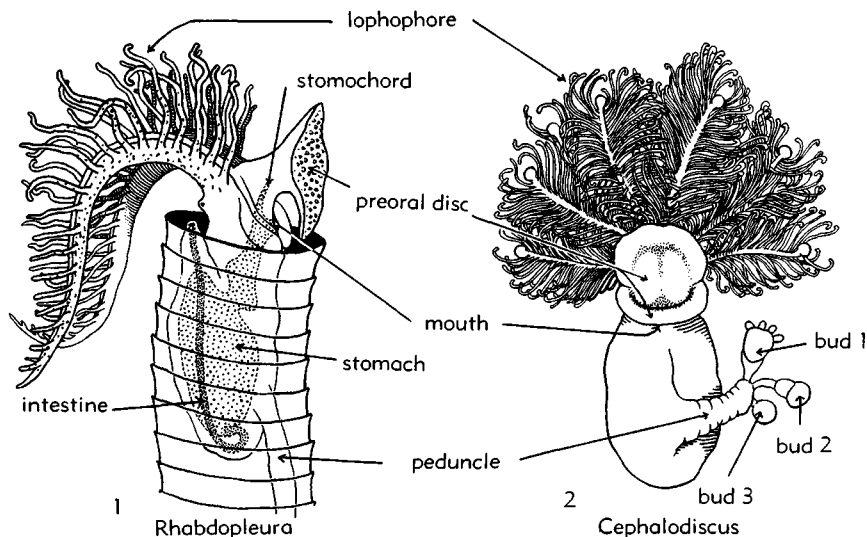

FIG. 2. Enlarged drawings of (1) *Rhabdopleura* and (2) *Cephalodiscus* showing the principal external features of the body in the Pterobranchia (11).

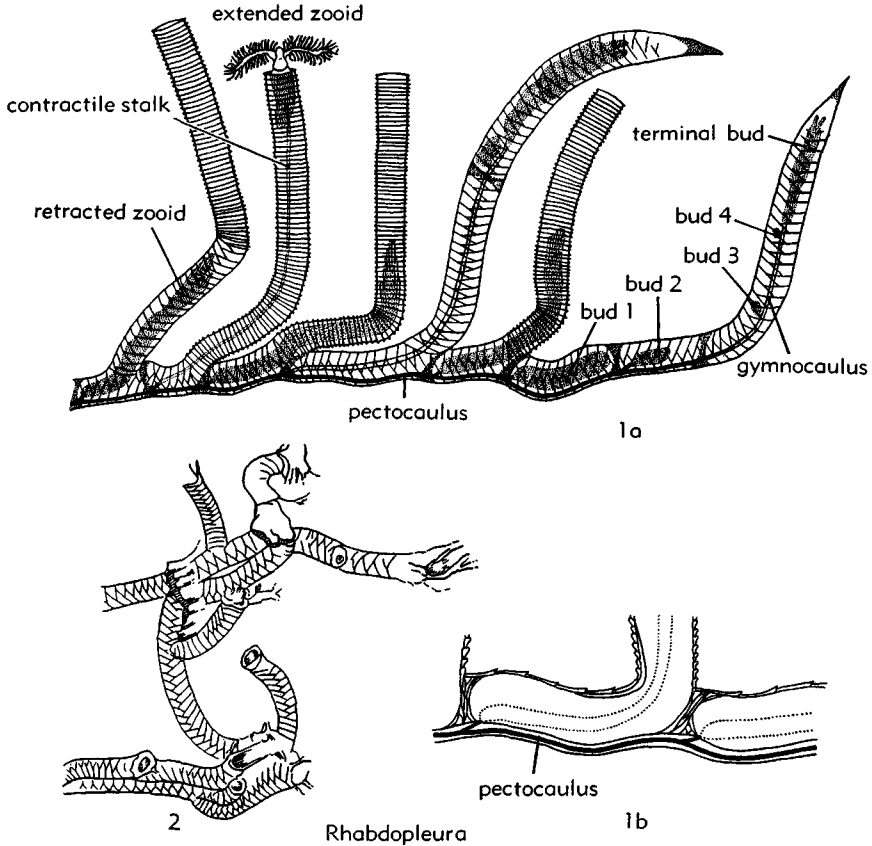

FIG. 3. Rhabdopleurida (p. V10).

tube. Normal zooidal buds develop successively behind the terminal bud on the gymnocaulus, forming a linear series with the youngest always nearest to the terminal bud. As each develops, it becomes sealed off by a transverse partition across the creeping tube, and at about this stage the gymnocaulus becomes chitinized to form the black stolon or pectocaulus (some 20 microns in diameter) and becomes embedded in the lower chitinous wall of the creeping tube. Each zooid in turn then forms by resorption a circular pore at the distal end of its chamber, and the zooid emerges, secreting as it grows upward the slender, erect, free portion of the zooidal tube. Branching occurs when one of the buds develops into a terminal bud instead of a normal zooid and starts to form its own creeping tube. Initial stages of development of the colony are only very imperfectly known.

Chitinous growth bands of the creeping tube are laid down in the form of half segments deposited alternately to left and right, so that the growth lines exhibit a characteristic median zigzag suture; the free zooidal tube consists of complete rings of chitin, each intersected by a single oblique suture marking the beginning and end of its formation. The initial rings at the base of the free zooidal tube are of course laid down discordantly on the growth bands of the creeping tube.

Family RHABDOPLEURIDAE Harmer, 1905

Characters of the order. *Cret.-Rec.*

Rhabdopleura ALLMAN, 1868 [**R. normani*]. *U.Cret.*(Pol.) - *Eoc.*(Eng.) - *Rec.*(E.Atl., S.Pac. - Ant-arct.).—FIG. 3, 1. **R. normani*, Rec.; 1a, portion of coenocium of living specimen showing expanded and retracted zooids, developing buds,

terminal bud, and characteristic growth lines of creeping and zooidal tubes, $\times 20$ (32); *1b*, long. sec. of part of coenocium showing pectocaulus, transv. partitions, and relations of growth bands, $\times 25$ (9).—FIG. 3, 2. *R. eocenica* THOMAS & DAVIS, *M.Eoc.*, *S.Eng.*; $\times 12$ (55).

Order CEPHALODISCIDA Fowler, 1892

Zooids forming free unattached associations, not true colonies; lophophore composed of several pairs of arms; gonads paired; one pair of branchial pores; coenocium extremely variable and generally irregular in form. *Ord.(Tremadoc.)-Rec.*

The coenocium of cephalodiscids is extremely variable in form, encrusting, dendroid or compact, and it may be elaborately spined. In the majority of species, separate zooidal tubes are formed, usually connected by cuticular substance; or somewhat rarely, completely embedded in it; in a few forms, the superficial openings (ostia) lead into a general cavity occupied by all the zooids and their buds. Where distinct zooidal tubes are present, usually they do not communicate with one another, and buds produced from the peduncle or stalk free themselves from the parent before secreting their own tubes. Zooids are able to leave their tubes and move about the coenocium, and in this way to secrete the connective cuticular tissue. In the less compact types of coenocium, the zooidal tubes are seen to be formed of growth bands comparable with

those of *Rhabdopleura* but irregular in form and spacing.

Family EOCEPHALODISCIDAE Kozłowski, 1949

Chambers relatively few (about 10), forming a compact, minute, unspined coenocium. *L.Ord.(Tremadoc.)*.

Eocephalodiscus KOZŁOWSKI, 1949 [**E. polonicus*]. *L.Ord.(Tremadoc.)*, Pol.—FIG. 4, 3. **E. polonicus*; $\times 20$ (32).

Family CEPHALODISCIDAE Harmer, 1905

Coenocium relatively large, variable in form, with or without individual zooidal tubes, or rarely absent altogether. *?Tert., Rec.*

Cephalodiscus M'INTOSH, 1882 [**C. dodecalophus*]. Several subgenera based on form of coenocium. *Rec.*, S. Hemis.(almost exclusively). [Silicified tubes from *M.Eoc.*, Fr., provisionally referred to this genus.]

C. (Cephalodiscus) [= *Demiothecia* RIDGEWOOD, 1906]. Coenocium branching, each ostium leading into cavity which is occupied in common by all zooids and their buds. *Rec.*—FIG. 4, 1. *C. (C.) hodgsoni* (RIDGEWOOD), Antarct.; *ca.* $\times 1.5$ (87).

C. (Idiothecia) RIDGEWOOD, 1906 [**Cephalodiscus nigrescens* LANKESTER, 1905]. Coenocium branching, composed of individual zooidal tubes embedded in common coenocial substance. *Rec.*

C. (Orthoecus) ANDERSON, 1907 [**Cephalodiscus indicus* SCHEPOTIEFF, 1909]. Zooids with individual tubes embedded in common coenocial

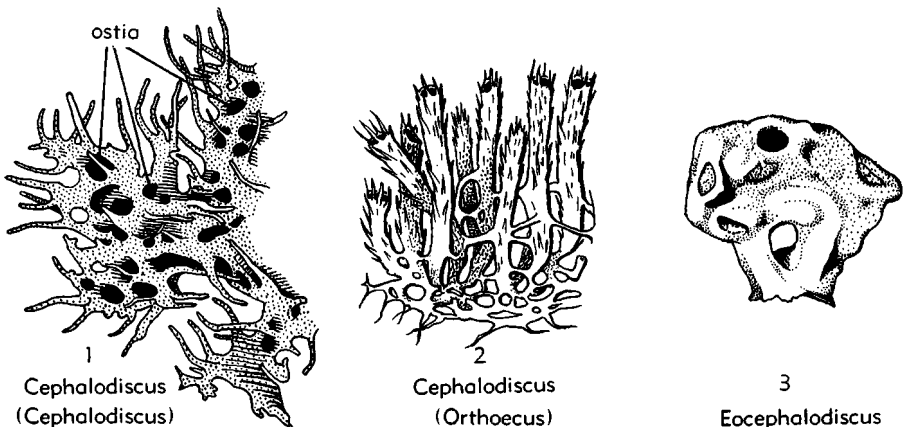

FIG. 4. Cephalodiscida (p. V11).

substance to form an irregular mass. *Rec.*—FIG. 4,2. *C. (Orthoecus) sp.*, IndoChina; *ca.* $\times 1.5$ (1).
C. (Acoelothecia) JOHN, 1931 [**C. (A.) kempi*].

Colony in form of branched meshwork of spines and bars without definite coenocelial cavities. *Rec.*
Atubaria SATO, 1936 [**A. heterolopha*]. Without any coenocidium. *Rec.*

GRAPTOLITHINA

DIAGNOSIS AND GENERAL FEATURES

Class GRAPTOLITHINA Bronn, 1846

Colonial marine organisms that secrete a chitinous exoskeleton with characteristic growth bands and growth lines in periderm; thecae arranged in single or double row along stipes, or rarely in less regular aggregates, in some orders polymorphic and related to a chitinized stolon system; rhabdosomes originating in a conical sicula, sessile or epiplanktonic, attached by nema (or virgula) from apex of sicula; stipes free or rarely encrusting. *M.Cam.-Carb.*

PREVIOUS STUDIES

In the early days of paleontology, graptolites attracted comparatively little attention. Their remains were thought originally to be those of plants, although LINNÉ believed them to be inorganic when bestowing the name *Graptolithus* upon *G. sagittarius* and *G. scalaris*, and it appears that WAHLENBERG (1821) was the first to recognize their animal nature. The generic name *Graptolithus* now has been suppressed by the International Commission on Zoological Nomenclature (Opinion 197), but it persists in the forms *Graptolithina*, *Graptoloidea*, and the anglicized version "graptolites."

The early phase of work by BRONN (1834), BECK (1839), and others, followed towards the middle of the century by publications of M'COY, BARRANDE, and SALTER, has given us a number of well-known generic names; but probably the first work of real insight and understanding is HALL's *Graptolites of the Quebec Group* (1865), where more than a dozen genera and over 50 species of graptolites (including dendroids) were described and beautifully figured.

Soon after this began the period of LAPWORTH's great contribution with a series of

papers (extending mainly from 1870 to 1880) devoted not only to a more exact understanding of structure and morphology and a more precise determination of species, but above all to the demonstration of their stratigraphical value (see especially his *Geological Distribution of the Rhabdophora*, 1879-80). This phase of work on the group may be said to have culminated in the *Monograph of British Graptolites* (1901-18) where LAPWORTH was assisted by Miss ELLES and Miss WOOD to produce an exhaustive and superbly illustrated monograph which has been an indispensable aid to workers all over the world. Comparable work was being done in Sweden, at first by LINNARSSON (who published but little), later by TÖRNQUIST and HADDING, while RUEDEMANN's *Graptolites of New York* (1904-8) and his recently published *Graptolites of North America* (1947) serve the same need for the North American continent. Description of Australian graptolite faunas, begun under M'COY, was continued by T. S. HALL; outstanding among recent work is that of HARRIS and D. E. THOMAS. BARRANDE's investigations of Bohemian graptolites have been continued in recent years by BOUČEK and (since 1940) in a great number of papers by PŘIBYL; comparable work on German Silurian faunas has been undertaken by HUNDT, MANCK, and MÜNCH.

Toward the end of last century a remarkable series of papers was published by HOLM (1890, 1895) and WIMAN (1895-1901), who may be said to have initiated the really detailed study of graptolite morphology, aided by novel techniques of solution and serial sectioning. After an interval of nearly 30 years, a revival of interest in the application of special techniques began with KRAFT's (1926) memoir on *Diplograptus* and *Monograptus*, and much of HOLM's

work which was left unpublished at his death was completed in a series of papers by BULMAN (1932-36). Other workers, including COX, EISENACK, MÜNCH, STRACHAN, WALKER, and THORSTEINSSON, have carried on this type of research and have added considerably to our knowledge of structure and development. The outstanding contribution of this character, however, was that of KOZŁOWSKI (1938, 1949), whose researches on the Tremadocian dendroids of

Poland have completely re-orientated our views on graptolite affinities. He and his pupils are continuing this type of work on material from higher horizons. Such investigations are, of course, limited by the discovery of suitably preserved material; it seems probable that further really outstanding advances will come in the near future from THORSTEINSSON's investigations of richly fossiliferous and varied limestone material of the Canadian Arctic.

TECHNIQUES

PREPARATION OF SPECIMENS

Detailed information about structure and development of graptolites is obtained almost entirely from specimens which have been dissolved out of their matrix and rendered more or less transparent by the use of various oxidizing agents. The actual processes and reagents employed naturally depend upon the nature of the matrix and the degree of carbonization of the fossil.

Pure limestone matrix can be dissolved readily with hydrochloric or acetic acid, the latter being sometimes preferable with fragile material on account of its more gentle action. The concentration should be adjusted so that effervescence is not too brisk, and is maintained by repeated addition of drops of concentrated acid. The condition of preservation of the graptolite periderm is an important factor, and some limestone material otherwise suitable is rendered useless for treatment because the graptolite remains have been too highly carbonized and have become so brittle that they crumble to a powder when freed from matrix.

Impure limestone generally requires a double treatment, involving solution of the calcareous matter first and then (after washing out all trace of HCl) solution or disintegration of the arenaceous or argillaceous remainder with hydrofluoric acid. Repeated washing and decanting to remove all HF is necessary before the graptolite remains can be picked out with a pipette under low-power binocular. Graptolites preserved in chert nodules of course can be dissolved out with HF without previous treatment.

Graptolites which have been dissolved out

of calcareous rocks may contain bubbles of CO₂ which should be removed in a vacuum desiccator before further treatment. Clearing is most usually done in a watchglass with potassium chlorate and concentrated nitric acid, but *eau de Javelle* and other bleaching reagents have been used. The period required varies with the thickness of periderm and the degree of carbonization, and can only be judged individually by constant observation through a low-power binocular; but the treatment cannot be prolonged, as a rule, beyond 20 minutes or half an hour without the specimens becoming too brittle to handle. Quite a high proportion of material successfully dissolved from its matrix proves unsuitable for further treatment of this kind.

Specimens which cannot be cleared are best mounted dry if robust enough, because surface features are so much more easily seen than when mounted in a relatively high-refractive-index medium. They may be affixed in a cell between 2 glass slides with a minute drop of gum arabic. Transparencies may be mounted in Canada balsam or some proprietary mountant such as Euparal, which has the advantage of not requiring perfect desiccation in absolute alcohol and clearing in xylol, thus eliminating processes in which damage to the specimen may occur. Some workers prefer mounting in glycerine, which further eliminates the whole "alcohol series" and also enables the specimen to be rolled over and viewed from different sides; but the technique of mounting in glycerine in glass cells presents many difficulties of its own. Storage of duplicate material is always best in glycerine.

Some rhabdosomes which are too large (e.g., *Dictyonema*) or too delicate (e.g., *Rastrites*) to hold together on removal of the matrix may be cemented to a glass slide with Canada balsam when one side has been completely exposed, and when thus supported the rest of the matrix can generally be dissolved safely. Such material cannot be cleared, however, as I have not yet found any mounting medium which will withstand the action of the clearing reagent.

Shale material that is exceptionally well preserved (e.g., in relief in pyrite) may also repay the trouble of solution of the matrix with HF after exposure of one surface and cementation to a glass plate; but in general there is little that can be done with specimens preserved in a shale or silt matrix beyond careful cleaning of the fossils with a fine needle under medium-power binocular. It is sometimes an advantage to varnish graptolites in their matrix and for this purpose mastic varnish, Canada balsam and Euparal may all be used. Good results are also being obtained from some of the modern plastics such as Marco Resin SB 26C.

Dissolved graptolites can be embedded and sectioned with a microtome, and although HOLM satisfactorily used only paraffin wax embedding, better results can be obtained usually by double embedding in collodion and paraffin wax. Zoology technicians, much more accustomed to such procedure, usually are willing to undertake this part of the paleontologist's work.¹ Pyritized graptolites, and those preserved in limestone but too highly carbonized for any of the solution treatments, can be sectioned by serial grinding, and with a limestone matrix permanent transfers can be taken with collodion films. Restorations can be made from serial sections (microtome or grinding), either by a modification of the method of preparing block diagrams, or by drawing on glass plates, or better still as wax models, the thickness of the wax plates to be used being determined by the frequency of the sections and the magnification employed. Most generally useful, at least for proximal-end development, are

reconstructions in the form of internal casts, made by cutting away a slightly exaggerated thickness of the internal and external walls, and assembling the resulting series of "thecal cavities."

ILLUSTRATION

The satisfactory illustration of graptolites has always presented a difficult problem. On account of their small size, enlarged figures are necessary to show details of structure and thecal form, but illustrations at natural size are so valuable as an aid to identification that the ideal is to have both.

Enlarged figures present no special difficulties, though it should be remarked that untouched photographs are rarely satisfactory; retouched photographs or wash drawings are far preferable (for example, see KRAFT, 1926, where both photographs of exceptionally high quality and wash drawings are reproduced; also excellent examples of retouched photographs in HOLM's plates, BULMAN 1932-36, and of wash drawings in WIMAN 1895-1901. At high magnifications, line drawings made with a camera lucida often leave little to be desired and can be reproduced cheaply as text figures (for example, WALKER, 1953).

It is the natural-size figures which present the special problem, both on account of technical difficulties in reproduction and the high degree of artistic skill needed for the original drawings (for here again photographs are rarely satisfactory). The steel engravings accompanying HALL's *Graptolites of the Quebec Group*, and TÖRNQUIST's lithographic plates are alike admirable, but these methods of reproduction are now obsolete even if authors were able to emulate their drawings. LAPWORTH solved the problem (*Monograph of British Graptolites*) by photographic reduction of enlarged chalk and wash drawings, reproduced at natural size by a collotype process to which MESSRS. BEMROSE devoted special care and attention. It is doubtful whether such plates could be produced today; but since modern zinc blocks cannot reproduce satisfactorily a line drawing of a graptolite rhabdosome at natural size, and the usual halftone screens are far too coarse, some form of collotype is essential for natural-size figures.

¹ If any granules of pyrite are present in the rhabdosome, the sections are likely to be torn and there is danger of damaging the microtome knife.

It cannot be overemphasized that there is no substitute for well-executed wash drawings or carefully retouched photographs. Innumerable examples of modern halftones (and even collotype plates) produced from untouched photographs at natural size or even at small magnifications serve mainly to show the limitations of this quick and labor-saving method of illustration. Because of these technical difficulties, there is inevitably a tendency nowadays to discard natural-size figures. Line

drawings, reproduced as text figures with magnifications of $\times 2$ to $\times 5$, probably will become the standard method of illustrating the general features of a graptolite rhabdosome in future; such figures can be drawn either with a camera lucida (at $\times 5$ to $\times 10$) or drawn on an enlarged photographic print which is subsequently bleached. The latter method is particularly useful with large or spreading rhabdosomes, and supersedes use of the Lapworth microscope (now unobtainable).

MODE OF LIFE

The class Graptolithina includes three orders (Tuboidea, Camarotoidea, Stolonoidoea), which appear to have been sessile, but concerning the ecology of which practically nothing is known. The Dendroidea and Graptoloidea, however, are better understood.

The Dendroidea, with their thickened "stems" and discoidal or ramifying basal organs, have the morphology of sessile organisms as was long ago recognized by HALL (1865). Their remains occur with other shallow-water benthonic invertebrates, and their sporadic distribution is consistent with a sessile mode of life. Few instances of attachment to shells or pebbles have ever been recorded, but the restoration attempted by RUEDEMANN (1925) for the Gasport lens is probably quite typical of the ecology of the group. Here are the fossilized remains of a muddy channel in the Lockport limestone sea, carpeted with a miniature forest of tough seaweed and bushy dendroid graptolites, while in the clearer water on either side up to the brink of the channel flourished a profusion of corals and crinoids, with associated brachiopods and mollusks.

The principal exceptions to such mode of life among the dendroids are *Dictyonema flabelliforme* and certain other Tremadocian species of *Dictyonema* provided with a nema, and the whole family of the Anisograptidae, here included in the Dendroidea. Such *Dictyonema* colonies probably lived attached by their nema to floating weed "like a bell at the end of a rope" (LAPWORTH, 1897), and it has been claimed that in adopting an epiplanktonic mode of life,

D. flabelliforme had taken the first step along the road leading to the Graptoloidea. The *Staurograptus* rhabdosomes attached to *Sphenophycus* described by RUEDEMANN (1934) are suggestive, but the possibility of a drifted association cannot be overlooked; and as with the sessile dendroids, the mode of life is deduced from indirect evidence. STØRMER (1933, 1935) has described and figured specimens of *D. flabelliforme* with what may be a vesicle and float, but it is not certain that any dendroids were truly planktonic. The wide distribution of all these forms, comparable with that of the Graptoloidea, is in marked contrast to that of the sessile dendroids.

The view that the true graptolites or Graptoloidea also were sessile organisms, living erect with the sicula embedded in the mud of the sea bottom, rests upon a misconception of the nature of the proximal end and long has been abandoned; the current view, that they were floating organisms, was first expressed by HALL (1865) and later developed by LAPWORTH (1897). In his classic paper, LAPWORTH draws a comparison with the Recent Sargasso Sea, picturing the graptolite rhabdosomes attached distally by their nemata to masses of floating weed, the periodic foundering of which supplied both carbonaceous matter and graptolite remains to the slowly accumulating, fine-grained black shales. This theory explains the significance of the nema and accounts for the wide geographical distribution of the graptolites (one of their most distinctive features), for their relation to the enclosing sediments, and to some extent

for the lithology of the rocks in which they most commonly occur.

The discovery of associations of rhabdosomes (synrhabdosomes) grouped around what appears to represent a central float (RUEDEMANN, 1895, and many later references) suggests that some at least among later Graptoloidea had acquired a truly planktonic method of existence. Certain

genera (*Phyllograptus*, *Dicranograptus*) seem to lack any chitinized nema (by which other graptolites were attached) so that their method of flotation remains unexplained; but now it is accepted universally that the general hypothesis of epiplanktonic or planktonic existence in open oceans accords best with the observed facts of morphology and distribution.

SIGNIFICANCE OF GRAPTOLITIC FACIES

It follows from the foregoing discussion that the Graptoloidea are not associated ecologically with any particular type of sedimentary environment, but that their remains may occur in almost any kind of sediment, shallow or deep, to which they have sunk or drifted. Nevertheless, their most distinctive association is with black muds devoid of almost any other fossils, and this occurrence constitutes the "graptolitic facies."

These black shales represent a type of sediment that is not confined to the Lower Paleozoic but occurs at various horizons through the geological column, and the problem of its origin is a general one to which considerable attention now is being given. While they may owe their sooty black color to the presence of carbon, such shales also may have a high iron-sulphide content (which imparts a black color) and must have accumulated under anaerobic conditions. Few analyses are available, but as much as 13 per cent carbon and 7 per cent sulphur has been recorded; pyrite infilling graptolite rhabdosomes in full relief indicates that the sulphide was syngenetic.

The essential condition is complete lack of bottom circulation so that dissolved oxygen, soon exhausted, cannot be replenished; whilst a high proportion of decaying organic matter may be contributed by animal and plant remains falling from the superficial aerated layers. Depth of water in itself has little or no controlling effect. At the present time, comparable conditions occur in the Black Sea (HUNDT, 1938), but also in narrow landlocked embayments such as the Norwegian fjords (STØRMER, 1938; STRØM, 1939) and even in coastal lagoons (SCUPIN, 1921; GRABAU, 1929).

It is certainly probable that such embayments and deltaic lagoons existed in the past, and reasonable to assume that graptolite remains might have drifted in from the open seas and accumulated there; but the extensive literature describing parallel grouping and current orientation of rhabdosomes (HUNDT, 1933-38; KLÄHN, 1930; KRAFT, 1926) and even ripple marks, rain prints and sun cracks in graptolite shales (FREBOLD, 1928; ÖPIK, 1929) probably gives an exaggerated impression of their importance. More or less uniform, haphazard distribution of graptolites in shales occurring over large areas, is considered far more characteristic by RUEDEMANN (1935), SCHMIDT (1935), STRØM (1939), RAYMOND (1942), and many others. That suitable conditions might develop in large seas and even oceans, especially in a warm or temperate climate and with submarine barriers to restrict bottom circulation, is admitted by STRØM, and in at least one instance (WILLIAMS & BULMAN, 1931) the existence of such barriers is considered probable on wholly independent grounds.

It is true, however, that graptolite remains often are confined to thin layers separated by considerably greater thicknesses of unfossiliferous strata, indicating that the main center or centers of graptolite evolution and dispersal lay outside the depositional areas in question.

RUEDEMANN (1925) has pointed out also that another class of graptolite shale exists, representing conditions which, though unfavorable, were by no means lethal to bottom life. Such shales as the Utica (in contrast to the Hartfell or Normanskill) contain some benthonic organisms and a variety of animals other than graptolites. Even

these, however, contrast with nongraptolitic (e.g., Lorraine) shales in the nature of other organisms, seaweeds and cephalopods with small arthropods and horny brachiopods predominating in the one, but polyzoans, brachiopods, and benthonic mollusks in the other. Such "mixed" shales probably represent depositions in quiet waters beyond the littoral zone, where muds probably were carried out by strong undertow.

It is likely enough that no general explanation will account for all occurrences of

these types of graptolite shale, however, but that each deposit must be assessed individually on its lithological and faunal characteristics and in relation to its general stratigraphical background. But it is a safe generalization that typical graptolite shales represent conditions more or less inimical to bottom life, and that graptolites themselves owe their distinctively wide geographical distribution to their superficial drifting mode of life.

DISTRIBUTION

GEOGRAPHICAL DISTRIBUTION

Since the distribution of true graptolites during life was mainly dependent upon drifting and the nature of ocean currents, distribution of their fossil remains may be practically world-wide, almost coextensive with that of the rocks of a particular age. Nearly all families, most genera, and many species are cosmopolitan: *Nemagraptus gracilis*, *Glyptograptus dentatus*, and *Mono-graptus priodon* are 3 examples of such species. Nevertheless, to judge by present records, many species are quite local, and some genera are at least comparatively restricted; thus the genus *Goniograptus* is characteristic of Australia and North America, but is unknown in Europe, and *Schizograptus*, generally distributed over northwestern Europe and found also in Australia, is known only by 2 specimens from the North American continent. It is not unlikely that detailed records will reveal, even among the Graptoloidea, the existence of certain provinces and that the distribution of various distinctive species may afford useful clues to the presence of marine connections between various regions in Paleozoic times. Reference may be made to *Didymograptus climacograptoides*, first described from South America (where it occurs in Peru, Bolivia, and Argentina), which is now known from the Lake District, southern Sweden, and Belgium. Again, the anisograptid fauna of the Tremadoc suggests that Norway had closer connection with the maritime provinces of Canada than with Sweden, Britain or Belgium. Such details of distribution await further investi-

gation, which will be complicated by a mass of misidentifications among existing records.

The sessile Dendroidea, on the other hand, stand almost at the other extreme. Many genera, such as *Dictyonema*, *Dendrograptus* and *Desmograptus*, certainly have an extremely wide, if not world-wide distribution, but few species have any notable geographic range. Less than one-half of the species constituting the rich fauna described by SPENCER (1884) and BASSLER (1909) from the Niagaran of Hamilton, Ontario, have been reported even from nearby localities in the United States, and so far as I know, none are reported reliably from any other continent.

Of the remaining orders, the Tuboidea (Idiotubidae) alone occur outside northwestern Europe, although it is probable that existing records are inadequate for generalization.

GEOLOGICAL DISTRIBUTION

Apart from some rather obscure European records of Middle Cambrian Dendroidea, the earliest occurrence of this order is Upper Cambrian. RUEDEMANN (1933) has described a small fauna, including species of *Dendrograptus*, *Callograptus*, and *Dictyonema*, from the Trempealeuan stage of Wisconsin, and more recently a larger fauna has been described from the Wilberns formation of Texas by DECKER (1945). Dendroid graptolites were clearly well established by Late Cambrian time. From then they persist with remarkably little conspicuous change to the Carboniferous, the highest dendroid being perhaps an undescribed species of *Dictyonema* from the Yoredale

Series of Yorkshire. The time range of many individual genera is also extremely long; both *Dictyonema* and *Callograptus* extend from Upper Cambrian to Carboniferous, *Desmograptus* from Lower Ordovician (Arenig.) to Carboniferous, and *Dendrograptus* from ?Middle or Upper Cambrian to Upper Silurian. Most genera range through the Ordovician and Silurian.

In the Tremadocian, *Dictyonema flabelliforme* and its descendant family the Anisograptidae, becoming epiplanktonic, achieved a wide distribution in North and South America, northwestern Europe, and the antipodes; and the earliest true graptolites (various species of *Didymograptus*) also appear in the Tremadoc. Though widely distributed (NW. Europe, Canada, New Zealand, and Australia), their remains are very rare and few graptolites of any kind are known from rocks of late Tremadocian age. By Early Ordovician time (Arenig, Deepkill, Levis, etc.) the Graptoloidea became an important component of the marine fauna of 5 continents. From thence onward, true graptolites retained and in fact increased their importance through the Ordovician and Early Silurian, diminishing in the Middle Silurian (Wenlockian or Niagaran) and becoming extinct toward the end of Ludlovian times. The latest undoubted graptolite is *Monograptus kayseri* (= *M. hercynicus*) of the ϵ gamma beds of Bohemia, generally regarded as late Ludlovian in age. The range of the group is thus far more restricted than that of the dendroids, and the range of individual genera (Fig. 5) is usually short, few extending through more than part of a single geological period; that of individual species is variable, some being confined to a single zone, others extending through 5 or 6 zones. The zones themselves represent variable time spans. Radioactivity figures suggest that the Silurian Period endured 40 to 50 million years, and in Britain this embraces some 20 graptolite zones; on this basis the duration of a single zone (or length of life of a short-ranged species) would be of the order of 2

million years. Other zones, such as those of the Utica of North America or Lower Ordovician of Australia, are undoubtedly much shorter; thus HARRIS & THOMAS in their latest correlation assign some 13 zones (from highest Lancefieldian to Yapeenian) as equivalent to the British Arenigian, surely not more than 10 or 12 million years (throughout which time, however, there are but 2 zones in Britain and only 4 in Scandinavia and America).

In most parts of the world, the shaly facies of the lower Paleozoic has now been zoned by means of graptolites, which are of exceptional value for long-range correlation. While a general similarity in the succession obtains, of course local variations occur. It would be out of place here to attempt any correlation of graptolite zones of different regions, but for the areas indicated reference may be made to the following authorities.

Sources for Correlation of Graptolite Zones

- EUROPE
- Belgium.* BULMAN, 1950; O. T. JONES, 1947; MAILLIEUX, 1926, 1939; UBAGHS, 1941.
- Bohemia.* BOUČEK, 1928, 1933, 1936; PERNER & KODYM, 1922; PŘIBYL, 1941-44, 1948.
- France.* BARROIS, 1892; PHILIPPOT, 1950.
- Germany.* EISEL, 1901; HUNDT, 1924; MÜNCH, 1952.
- Great Britain.* ELLES, 1925; O. T. JONES, 1909, 1935; LAPWORTH, 1879-80; LAPWORTH, ELLES & WOOD, 1914.
- Scandinavia.* HADDING, 1913, 1915; LAURSEN, 1940, 1943; MOBERG, 1910; MONSEN, 1925, 1937; PEDERSEN, 1922; THORSUND & WAERN, 1948; TÖRNQUIST, 1890, 1892, 1897, 1901, 1904; TROEDSSON, 1923; TULLBERG, 1882, 1883.
- South, Central & Eastern Europe.* GORTANI, 1923; HABERFELNER, 1936; HERITSCH, 1934; PŘIBYL, 1952.
- NORTH AFRICA. TERMIER & TERMIER, 1948; WATERLOT, 1941.
- NORTH AMERICA. RUEDEMANN, 1904, 1908, 1919, 1925, 1933 (Cam.), 1947; DECKER, 1936, 1945 (Cam.).
- SOUTH AMERICA. BULMAN, 1931; LOSS, 1951.
- ASIA. HSÜ, 1934; SUN, 1933, 1935; YIN & LU, 1936.
- AUSTRALIA. HARRIS, 1935; HARRIS & KEBLE, 1932; HARRIS & THOMAS, 1938; KEBLE & BENSON, 1939; O. A. JONES, 1927.
- NEW ZEALAND. BENSON & KEBLE, 1935, 1936.

GRAPTOLITE AFFINITIES

Because the graptolites are an extinct group of animals whose soft parts have left

little or no trace upon the chitinous exoskeleton, their affinities always have been in

dispute. Originally regarded as inorganic (LINNÉ, 1735) or of vegetable nature (VON BROMELL, 1727; BRONGNIART, 1828), at different times they have been assigned to the

Cephalopoda (WALCH, 1771; WAHLENBERG, 1821; SCHLOTHEIM, 1822), Coelenterata (HALL, 1865; ALLMAN, 1872; NICHOLSON, 1872; LAPWORTH, 1873; BULMAN, 1932),

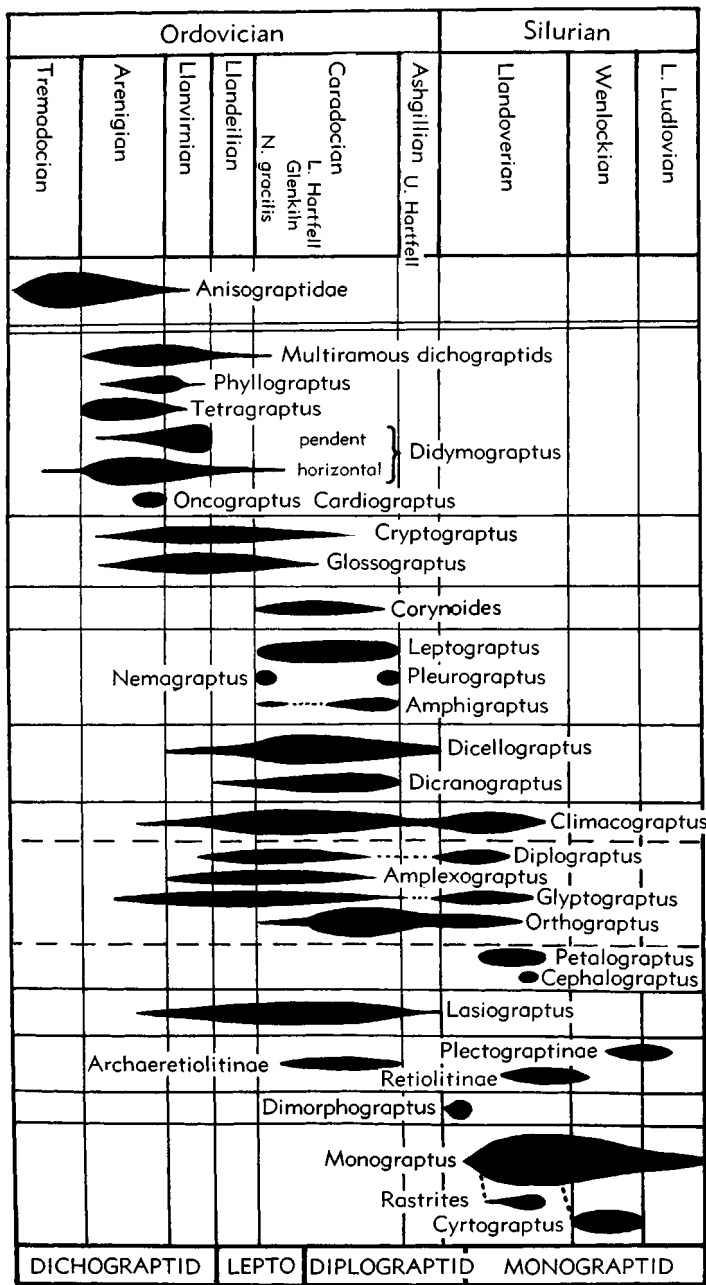

FIG. 5. Geological distribution of certain graptoloid genera. Number of species only approximately indicated; no attempt made to show relative importance of genera.

Polyzoa (SALTER, 1866; ULRICH & RUEDEMANN, 1931), Pterobranchia (SCHEPOTIEFF, 1905), or considered to occupy an isolated position in the animal kingdom not clearly related to any living group of organisms (WIMAN, 1895; PERNER, 1895; RUEDEMANN, 1895; FRECH, 1897; ELLES, 1922).

It has been asserted repeatedly that the graptozooid must have been a bilaterally symmetrical animal, because the bilaterality of the thecae (demonstrated by growth lines and growth bands of sicula and thecae alike) is an inherent feature, not one resulting from their position on the colony (WIMAN, 1895). Admittedly a distinction from the Hydrozoa, this is not wholly incompatible with coelenterate affinities; and it is even possible to find amongst the coelenterates something broadly comparable with the growth lines so distinctive of the graptolite periderm.

However, now that details are available of the histology of the periderm and of the stolon system (KOZŁOWSKI, 1938, 1947, 1949) the evidence begins to point more decisively to pterobranch affinities. The existence of fusellar and cortical layers in the periderm, and the growth bands of the fusellar layer, find their exact counterpart in the coenocelial tissues of the pterobranchs. Moreover, in no other living organisms is there such an organ as the pectocaulus (black

stolon) to which the chitinized stolon system of the graptolites is so closely comparable. The actual method of budding seems to have been somewhat different; in *Rhabdopleura* there is a permanent terminal bud ("blastozooid *inachevé*") behind which successive individuals develop from the stolon, while in the Dendroidea each stolothecca¹ in turn seems to have represented the terminal bud of its branch (p. V23). In the Graptoloidea, evidence for the budding of successive thecal zooids one from another is even clearer, and the stolon, although it may well have existed, must have been unchitinized. These differences from *Rhabdopleura* may not be very significant, however; the living *Cephalodiscus*, which is placed without question in the same class as *Rhabdopleura*, has no stolon system at all and is not a truly colonial organism, and the two budding processes of *Rhabdopleura*, on the one hand, and the graptolites, on the other, are closely paralleled by the monopodial budding with terminal growing points, and the sympodial budding, both described by HYMAN in calyptoblastean hydroids.

For a detailed discussion of the question of graptolite affinities, reference may be made to KOZŁOWSKI, 1947.

¹Hence in effect, each autotheca, since the stolothecca is in reality little more than the proximal, immature portion of its daughter autotheca.

NATURE OF GRAPTOLITE ZOOID

Polymorphism in the coelenterate hydrosoma is due to the development of special reproductive or protective individuals in addition to the nourishing individuals; and those who favor coelenterate affinities for the graptolites generally regard the bithecae as housing such protective polyps. Dimorphism among higher organisms is usually sexual and the occurrence of autothecae and bithecae on the stipes of many graptolites is taken by KOZŁOWSKI (1949) to indicate the presence of male and female zooids. In *Rhabdopleura* and *Cephalodiscus*, males and females are usually indistinguishable, but certain species do show dimorphism. Thus, in *C. sibogae*, the males are degenerate and bear almost atrophied lophophore structures. KOZŁOWSKI interprets the graptolite bithecae

as representing such males, their reduced state being reflected in the universal absence of apertural processes in the bithecal skeleton. The autothecae housed the female zooids, which probably possessed a well-developed lophophore in the form of 2 arms or groups of arms, as indicated by the apertural modifications of bilaterally symmetrical thecae of most graptolites and especially certain Graptoloidea. The autothecae of several dendroid species have furnished traces of what are claimed to be embryos. Disappearance of the bithecae in the Graptoloidea implies a transition to hermaphroditism, the bithecal males being eliminated and the autothecal females becoming hermaphrodite. The actual process of elimination probably was somewhat different in different groups.

It is improbable that the stolothecae contained separate zooids; on the contrary, it is virtually certain that each stolotheca was secreted by the same individual as the autotheca which succeeds it (and with which its periderm is continuous). Structural resemblances between stolothecae and bithecae (p. V25) are accountable if the stolotheca was secreted by an immature zooid with the preoral segment and lophophore still relatively undeveloped, while the bitheca was secreted by a reduced male in which these structures remained always undeveloped.

The laminated cortical tissue, to some extent at least universally present among graptolites, can only be due to the existence of some soft tissue enveloping the entire colony; for the zooids, being attached to the stolon, were not free to leave their thecae and secrete this secondary skeletal tissue as they do in *Cephalodiscus*. By analogy with certain Polyzoa, such a membrane probably constituted a direct prolongation of the wall of the upper edge of each zooid; and such zooids, attached at the base to their stolons and to an extrathecal membrane distally, can have had but little mobility. This indicates a more advanced stage of colonial organization than exists among modern pterobranchs, and is consistent with the transition to the hermaphrodite state which is characteristic of colonial organisms. The precise details of morphology are extremely difficult to visualize, however; and if there

were an external membrane uniting all the zooids, then the lophophore and proboscis must have been external to this, in which case the fusellar tissue itself can scarcely have been secreted by the proboscis (as it is in the pterobranchs).

The nature of the sicular individual remains more obscure. The prosicula seems to represent the skeleton of a larva developed from a fertilized egg, originally exhibiting little trace of basal disc or nema, but possibly covered by some extrathecal membrane and attached by a fleshy peduncle. This prosicular skeleton is so sharply distinct from that of the metasicula, however, that KOZŁOWSKI even believes them to have been secreted by different individuals. On this view, the prosicula corresponds to a fixed larval form, which on degeneration is replaced by a metasicular individual whose body occupied the entire cavity of the sicula to the apex of the prosicula; such a process finds some analogy in the embryonic stages of certain Polyzoa. The initial bud (or sicular stolotheca) likewise extends to the apex of the prosicula, perhaps originating as a bud from the peduncle of the metasicular zooid, and then growing up with the metasicular individual until it emerges generally through a foramen produced by resorption in the wall of the sicula in a manner comparable with the normal process of budding in *Rhabdopleura* (or less commonly through a notch as in certain monograptids).

DENDROIDEA

Order DENDROIDEA Nicholson, 1872

Sessile Graptolithina usually attached by apex of the sicula (which is then generally more or less embedded in secondary chitinous material to form a rootlike base), rarely encrusting or attached by nema; stipes composed of autothecae, bithecae, and stolothecae produced from a stolon in regularly alternating triads; rhabdosome typically erect, dendroid, developed by dichotomous or irregular division, with anastomosis or dissepimental connection between adjacent stipes in many forms. *M. Cam.-Carb.*

MORPHOLOGY

From the point of view of gross morphology, Dendroidea are characterized by their erect multiramous dendroid rhabdosomes, though encrusting rhabdosomes are less commonly met with, and those most nearly related to the Graptoloidea were suspended by a comparable delicate nema attachment. Thecae are rarely visible, for in dendroid rhabdosomes the ventral side of the stipes is usually directed inward; preservation is commonly poor, so that the group long has been imperfectly understood and ill defined. Gradually the underlying complexity of

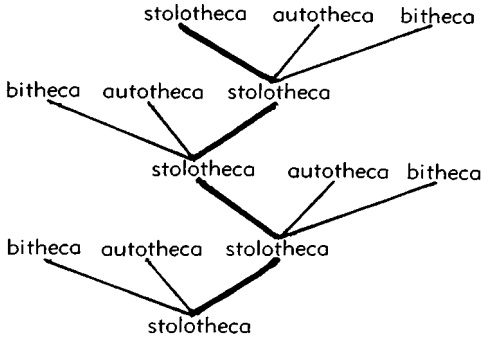

FIG. 5A. Arrangement of graptolite thecae in alternating triads according to the "Wiman rule."

branch structure has been recognized (HOLM, 1890; WIMAN, 1895-1901; and others) and recently the discovery of exquisitely preserved material in siliceous nodules from the Tremadocian of Poland (Kozłowski, 1938, 1949) has enabled an almost complete description of skeletal morphology to be given. Many genera, however, still are known only as flattened films and some can be referred to the Dendroidea only with reservation.

With recognition of other orders than the Dendroidea and Graptoloidea, it has become apparent that the diagnostic feature of the Dendroidea is not so much the possession of autothecae, bithecae, and stolothecae as the regularity of their development from a stolon in alternating triads on what has

been termed the "Wiman rule," diagrammatically indicated in Fig. 5A. It is on the basis of thecal pattern, for example, that the Cyclograptidae now are excluded from the Dendroidea, and the Anisograptidae here are admitted.

PERIDERM

The periderm of the Dendroidea (Kozłowski 1938, 1949) consists of 2 layers, a main internal fusellar layer constructed of short growth segments, generally disposed with bilateral symmetry, and a laminated external cortical layer (Fig. 6). The fusellar layer corresponds closely in its formation to the zooidal tubes of the pterobranchs, *Rhabdopleura* and *Cephalodiscus*. The cortical tissue is more abundantly developed in *Cephalodiscus* than in *Rhabdopleura*, and it varies greatly in amount in the Dendroidea; some dendroid graptolites exhibit so much "secondary thickening" that underlying structures are obscured completely, whereas even the growth lines of others remain clearly visible. In general, the dendroids show a greater development of cortical tissue than do the graptoloids, and there is more at the base of a rhabdosome than at its distal extremities; in fact, secondary thickening of what is presumably cortical tissue rather commonly converts the normally thecate stem of a dendroid into a thickened nonthecate stem.

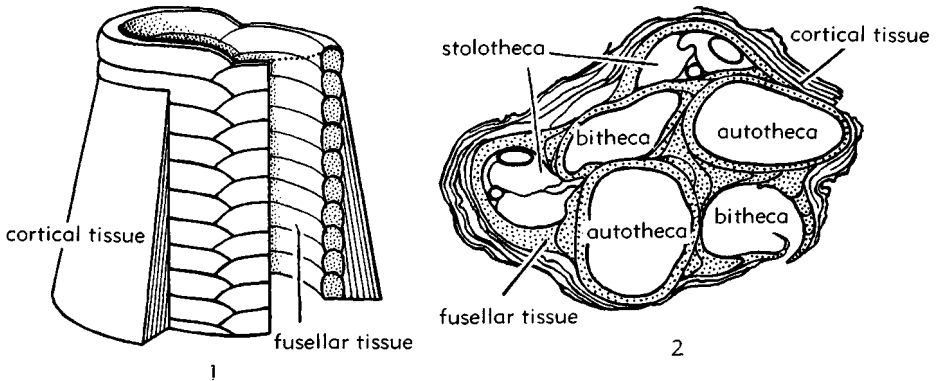

FIG. 6. Structural features of graptolite thecae. 1, Diagram of the periderm of a graptolite showing fusellar tissue laid down in alternating half rings, surrounded by laminated cortical tissue (32). 2, Transverse section of a *Koremagraptus* stipe ($\times 130$) showing cortical tissue surrounding fusellar tissue (stippled), which has the form of complete tubes for autothecae, and split tubes for bithecae and stolothecae; where growth bands are oblique (as in bithecha at lower right) many such bands are cut by the plane of the section (9).

THECAE

STOLOTHECAE

The stolothecae (formerly called budding individuals) form a continuous closed chain along the dorsal side of the branch. Externally, each stolothecha terminates distally against the base of an autothecha, liberating at the same level a bitheca on one side and another stolothecha on the other (Fig. 7); and when only this much of the branch structure was known, the term "budding individual" was not inappropriate. Internally, however, each stolothecha is now known to enclose at its distal end a thin-walled proximal extension of the daughter stolothecha and bitheca, together with a long stolon from the base of the autothecha; and throughout its whole length runs a segment of the main stolon—an organ analog-

ous to the pectocaulus of *Rhabdopleura*. That each stolothecha is no more than the proximal portion of its daughter autothecha is strongly suggested by the relations of growth lines of the fusellar tissue (Figs. 7,2,3; 8,1), but it is convenient to retain the designation stolothecha for this proximal portion. It appears that, instead of the permanent terminal "leading bud" of *Rhabdopleura*, each autothecha in turn has been the terminal theca of its branch and that at a certain stage in its development it produces from a point back along its stolon 2 buds, a bithecal zooid, and an autothecal zooid (Fig. 8,1,2). The budding processes in *Rhabdopleura*, on the one hand, and among graptolites, on the other, closely parallel the "monopodial budding with terminal growing points" and the "sympodial budding" of calyptoblastean hydroids.

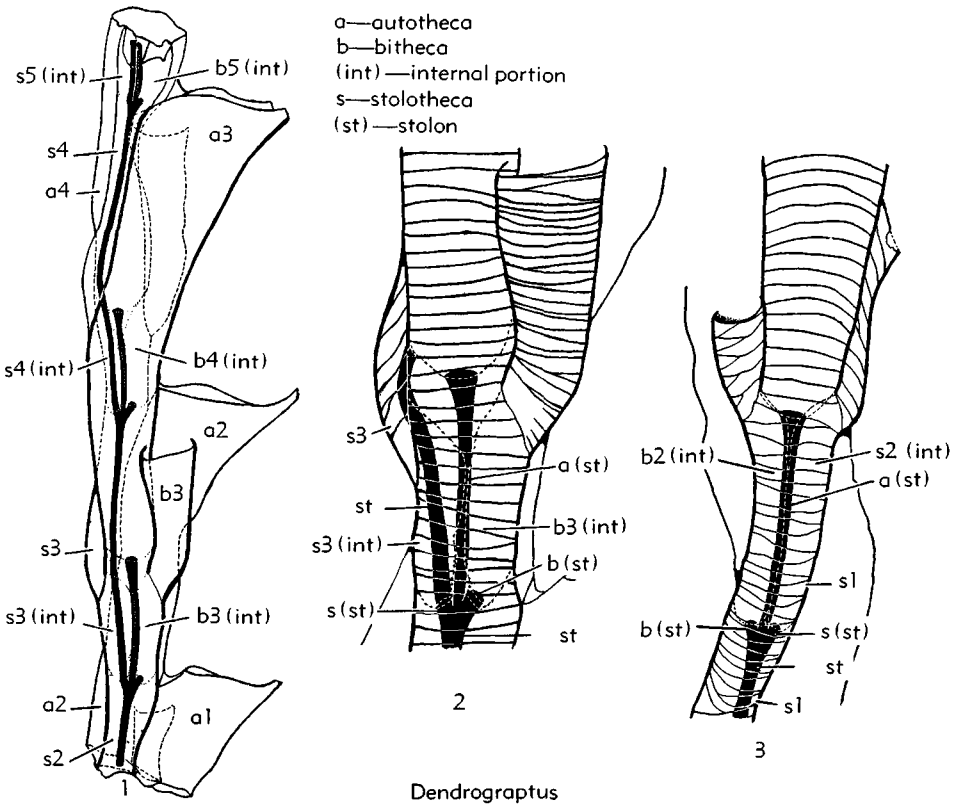

FIG. 7. Thecal constitution of a dendroid stipe. 1, *Dendrograptus regularis* KOZŁOWSKI ($\times 40$) viewed as transparency with growth lines omitted; stolon system in solid black, stolothecha and daughter thecae in heavy outline. 2, Portion of same with growth lines ($\times 80$). 3, *D. communis* KOZŁOWSKI ($\times 80$), distal end of branch showing immature stolothecha and bitheca (32).

AUTOTHECAE

The autotheca (formerly called hydrotheca) is the largest and most conspicuous of the 3 types of dendroid thecae, and comprises a relatively long autothecal stolon and the theca proper. The stolon and the thin-walled rounded base of the theca are

enclosed within the stolotheca of the preceding generation, but practically the whole of what is termed autotheca is external, and its dorsal wall continues that of the stolotheca uninterruptedly. The mid-ventral line is usually marked by the zigzag wedging out of growth bands laid down alternately to right and left, and where the whole

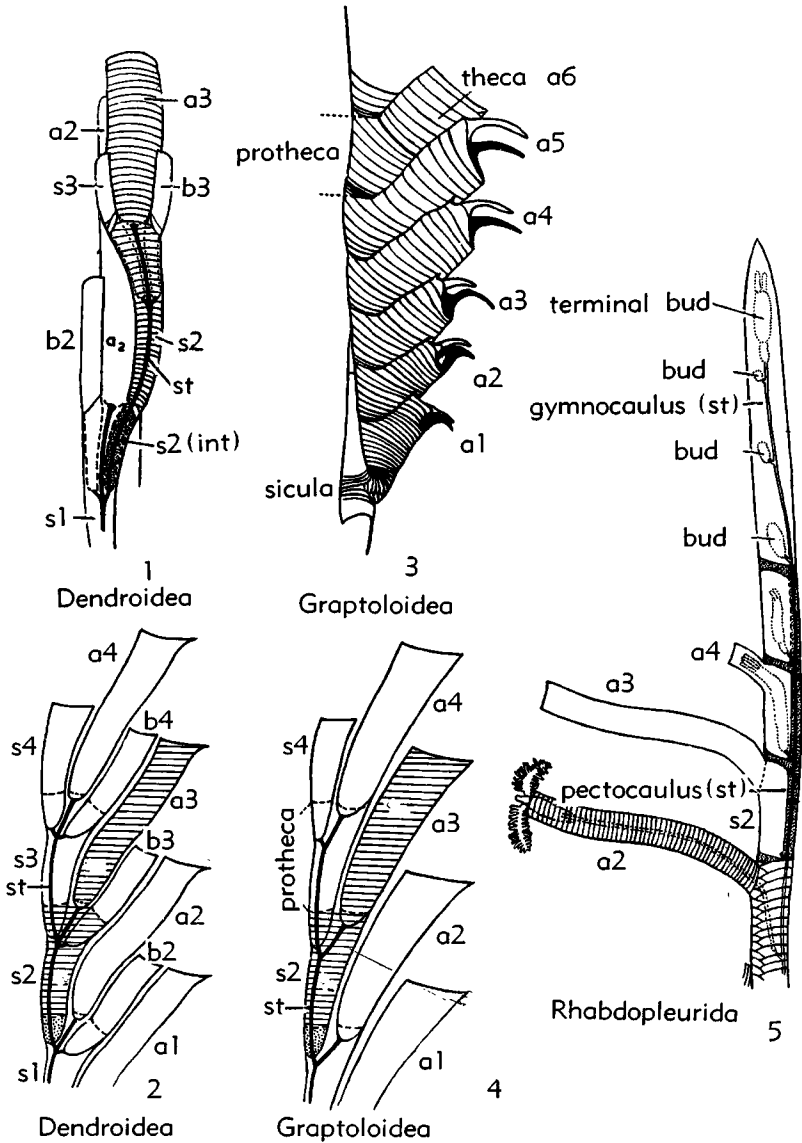

FIG. 8. Comparison of branch structure and mode of budding in Dendroidea (1,2), Graptoloidea (3,4), and Rhabdopleurida (5). 1, Growing end of dendroid stipe (diagrammatic) with one complete autothecal unit shaded (internal portion of stolotheca stippled, external portion and daughter autotheca with growth lines); 2-5, shaded for comparison (31). Letter symbols as in Fig. 7.

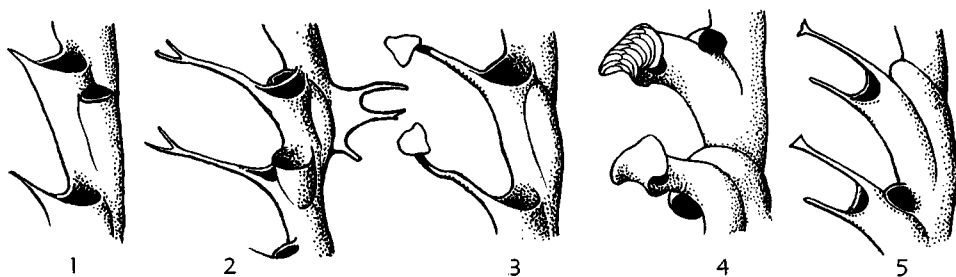

FIG. 9. Autothecal modifications in Dendroidea. 1, Apertural spine or denticle on hydrothecae of *Dictyonema flabelliforme* (EICHW.). 2, Forked apertural spine of *D. cervicorne* HOLM. 3, Apertural spine with platelike termination in *D. peltatum* WIMAN. 4, Laterally expanded and reflexed ventral process (languette) shown by *Dendrograptus cofeatus* KOZL. 5, Ventral and dorsal spines in *Dictyonema rhinanthiforme* BULMAN.

distal region of the autotheca is isolated from the branch, a similar zigzag line usually is visible on the dorsal side as well. For the most part, the autothecae are practically straight, commonly provided with an apertural (ventral) process or spine, rarely with a dorsal spine, or both. In some forms (e.g., *Dendrograptus cofeatus* KOZL.), the ventral process is transversely enlarged and recurved over the aperture, but the dendroid autothecae rarely exhibit apertural modifications comparable with the more extreme types of elaboration in the Graptoloidea. Some isolation of the distal end is not uncommon, accompanied by elongation of the theca, reaching its maximum in the Acanthograptidae (Fig. 9).

BITHECAE

The bithecae are shorter and, as a rule, narrower than the autothecae, and are commonly inconspicuous in external view, though in some species they form marked swellings along the branch, as in *Dictyonema cervicorne*, where they were for the first time recognized by HOLM. Their wall is incomplete along the side which is in contact with the branch, and they are without apertural spines. They further resemble the stolothecae and differ from the autothecae in possessing a very short stolon and in having a long, thin-walled proximal portion enclosed within the stolotheca of the preceding generation.

In its simplest form, the bithecal tube is nearly straight, and owing to its shortness as compared with the autotheca, its aper-

ture is situated beside that of the autotheca of the preceding generation. Various modifications are known, mostly related to increase in length (Fig. 10). In most species the behavior of the bithecae is constant, but in a few it is variable and several types occur together, in some (as in *Dictyonema falciferum*) characterizing a particular portion of the rhabdosome.

THECAL GROUPING

The dendroid branch unit is the three-fold association of autotheca, bitheca, and stolotheca, and as the stolotheca does not open to the exterior (except at the growing end of a branch) and was not inhabited by a separate zooid, the effective unit is the autotheca and bitheca. Owing to their relative difference in length, this smaller unit is split, for the bithecal aperture is associated with the autotheca of the preceding generation.

A complex but surprisingly regular grouping of autothecae and bithecae has been demonstrated in *Acanthograptus suecicus* accompanying extreme elongation of the thecae, and probably something very similar characterizes all members of the Acanthograptidae, where variously associated thecae open together in groups or "twigs." A less regular grouping, unaccompanied by thecal elongation, is described by KOZŁOWSKI in *Acanthograptus czarnocki*. In *A. suecicus*, each twig is composed of 2 autothecae and 2 bithecae, the autothecae being separated by 2 intervening generations while the bithecae belong to successive

generations. Thus, the plan of arrangement may be indicated as follows (using *a* for autotheca and *b* for bitheca): twig 1—*a*1, *a*3, *b*2, *b*3; twig 2—*a*2, *a*5, *b*4, *b*5; twig 3—*a*4, *a*7, *b*6, *b*7; twig 4—*a*6, *a*9, *b*8, *b*9, etc. (Fig. 11,1).

In other genera, such as *Koremagraptus*, the grouping may be more complex, but it is then almost certainly less regular; anastomosis occurs between adjacent branches, exchange of individuals may take place, and several main stolons may be present in any given branch. Some of WIMAN's sections of *Koremagraptus formosus* show 30 or more thecae at the same level in a stipe (Fig. 11,2). The same may hold true to a less extent for some *Desmograptus* species, but in the absence of serial sections it is

difficult to determine whether or not exchange of individuals accompanies anastomosis and subsequent separation of the stipes. Under such conditions, however, any thecal associations are likely to be random; but beneath all, in the Dendroidea, lies the regular triad proliferation from the stolon.

MODE OF BRANCHING

Preceding any bifurcation of a stipe, 2 main stolons must be produced and hence at a branching division or node 2 stolothecae must arise. The former view (BULMAN, 1938) that the production of 2 stolothecae could be accompanied in different species by the suppression of either a bitheca or an autotheca seems to be based on a misinterpretation. Since the stolothecae are essential-

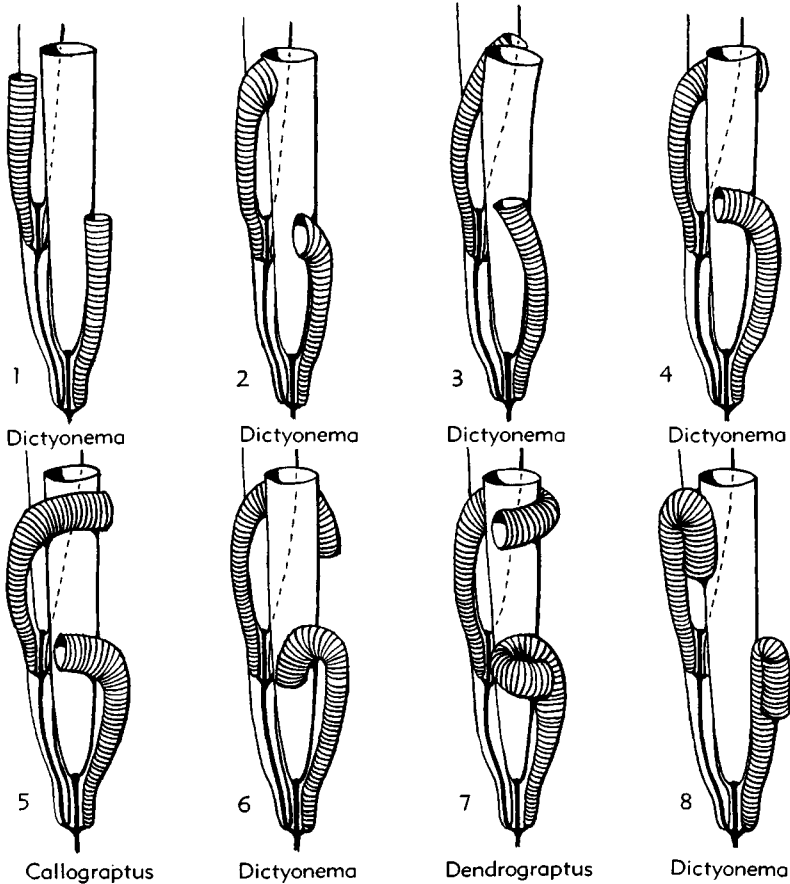

FIG. 10. Variations in form and relations of dendroid bithecae (shaded), 1, *Dictyonema flabelliforme* (EICHW.). 2, *D. peltatum* WIMAN. 3, *D. cotyledon* BULMAN. 4, *D. rarum* WIMAN. 5, *Callograptus infrabithecalis* KOZLOWSKI. 6, *D. inconstans* BULMAN. 7, *Dendrograptus cofeatus* KOZL. 9, *Dictyonema wysoczki-anum* KOZL.

ly the proximal portions of autothecae, it follows that the branching division entails production of 2 autothecae in place of autotheca and bitheca (i.e., the suppression of a bitheca). In spite of this, the external regularity in arrangement of the thecae along the stipe is not disturbed; slight adaptation in length of stolon and length of bitheca insures that the normal association of bithecal and autothecal apertures persists (Fig. 12,1).

Bifurcation of a complex branch containing several main stolons and elongate tubular thecae (Fig. 11,2) may involve

merely the separation of certain stolons, together with some associated autothecae and bithecae. Here, the technical branching division of the stolon involving the production of 2 stolothecae does not seem to be related immediately to the bifurcation of the stipe.

DISSEPIMENTS

In *Dictyonema* the branches are united by hollow transverse threads called dissepiments, which may be rather erratic in spacing and direction, but in certain species are extraordinarily regular. They also char-

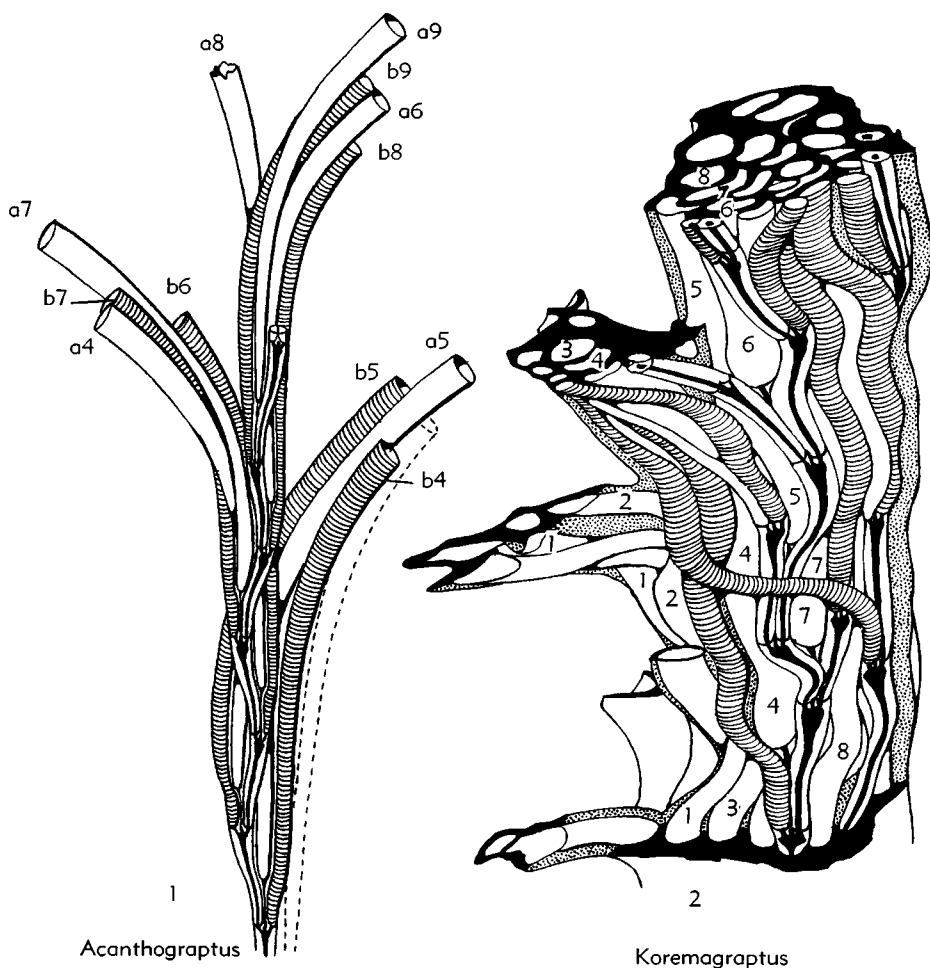

FIG. 11. Thecal grouping in the Acanthograptidae. 1, *Acanthograptus succicus* (WIMAN) showing regular association of 2 autothecae and 2 bithecae to form twigs. 2, Restoration from serial sections cut by WIMAN of *Koremagraptus* sp., showing complex branch with numerous main stolons and larger, more irregular, twigs (bithecae shaded; numbering of some of the autothecae is only to identify such thecae as can be traced throughout the series figured).

acterize *Ptiograptus* and a few may be developed in certain species of *Callograptus*. It was argued by BULMAN that these structures were related to the bithecae (which exceptionally may extend out along them); but they are considered by KOZŁOWSKI to belong to the cortical skeleton, secreted by an external sheet of soft tissue. The dorsal flange structure of *Dictyonema cotyledon* BULMAN is also presumably extrathecal in origin, and comparable features exist in other species. It is extremely doubtful whether stipes are ever connected by apertural spines, and for this reason I reject RUEDEMANN's genus *Airograptus*.

DEVELOPMENT

The astogeny of the dendroid rhabdosome is now known from serial sections or from cleared and transparent preparations for a number of species of *Dictyonema*, *Dendrograptus*, *Acanthograptus*, and *Rhipidodendrum*, and apart from the last named, the general plan appears to be nearly uniform.

In all species, the rhabdosome originates

in a sicula, which, as shown by WIMAN in the Graptoloidea, consists of an apical portion (prosicula) and an apertural portion (metasicula). The most complete account has been given by KOZŁOWSKI (1949) for *Dendrograptus communis*, which may serve as a type (Fig. 13).

The prosicula is a thin-walled, homogeneous, almost cylindrical tube, closed and flattened at the base and usually developing a well-marked basal disc of attachment. Its walls are strengthened by a spiral thread (*Schraubenlinie, ligne hélicoidale*) coiled indifferently in a clockwise or counterclockwise direction; but the dendroid prosicula, as at present known, never exhibits any longitudinal fibers comparable with those of the graptoloid prosicula (Fig. 36), possibly because the nema is not developed.

In contrast with the prosicula, the metasicula is sharply differentiated by its close-set growth lines. These are not so strikingly regular as in the Graptoloidea, but there is a general zigzag line down the dorsal and ventral sides and the growth bands are alternating half rings for the most part,

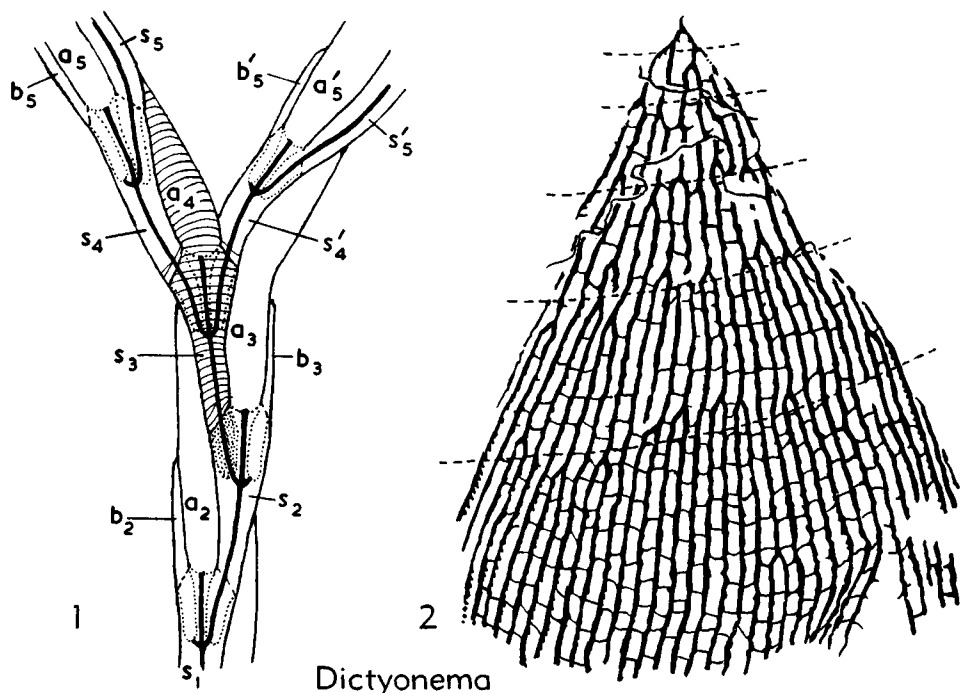

FIG. 12. Branching in *Dictyonema flabelliforme* (EICHW.) (72). 1, Diagram of branching division with two stolothecae (s_4 and s'_4) in place of stolothecca and bithecca; parent stolothecca s_3 and daughter autothecca a_4 shaded. 2, Approximate zones of branching in a rhabdosome of *D. flabelliforme*, $\times 1$.

giving a definite bilateral symmetry to the metasicula. With continued growth, the *Dendrograptus communis* metasicula begins to develop the dorsal and ventral apertural processes so pronounced in the adult.

The initial bud, or sicular stolothecha, originates in a pore produced by resorption in the wall of the prosicula, and a prosicular origin for this bud is prevalent, if not universal, in the Dendroidea. After a short period of growth addressed against the wall of the prosicula and metasicula, it gives rise distally to the first triad, consisting of autothecha, stolothecha, and bitheca; proximally it can be traced within the prosicula to the basal disc as an extremely thin-walled tube containing the initial stolon. The first triad of thecae thus produced (Fig. 13,3,4) constitutes the initial part of the main stem of the colony, which in this species extends for 4 or 5 consecutive generations before beginning to branch.

Restated in modern terminology, WILMAN's account of the development of *Dictyonema cavernosum* (Fig. 14,1) would be almost identical, save that details of the enclosed part of the sicular stolothecha and the stolon itself were not available, and the branching of the colony begins with the second thecal triad. Indeed, it would seem that the principal variations in the astogeny

of the dendroid rhabdosome concern the rapidity of branching, and *Dictyonema flabelliforme* (formerly thought to be a rather distinct type) can be re-interpreted as developing on exactly the same plan but showing an extremely concentrated series of branching divisions (Fig. 14,2). The establishment of the thecal-grouping plan of *Acanthograptus suecicus* (based on description by I. STRACHAN) is represented in Fig. 14,3.

Rhipidodendrum (Fig. 14,4), however, reveals a distinct variation and no doubt others will come to light. In this genus, the first stolonal node (KOZŁOWSKI, 1949) produces only 2 thecae (bitheca and stolothecha), succeeded usually by one normal triad and then a concentrated series of branching divisions. There is much variation in this species, however, and in some colonies even the second node is a branching division.

CLASSIFICATION

At present we are in the stage of knowing the morphology of certain species of a few dendroid genera in extreme detail, while the majority are incompletely known and are merely represented by flattened mineralized films. Classification must still rest, therefore, largely upon the general

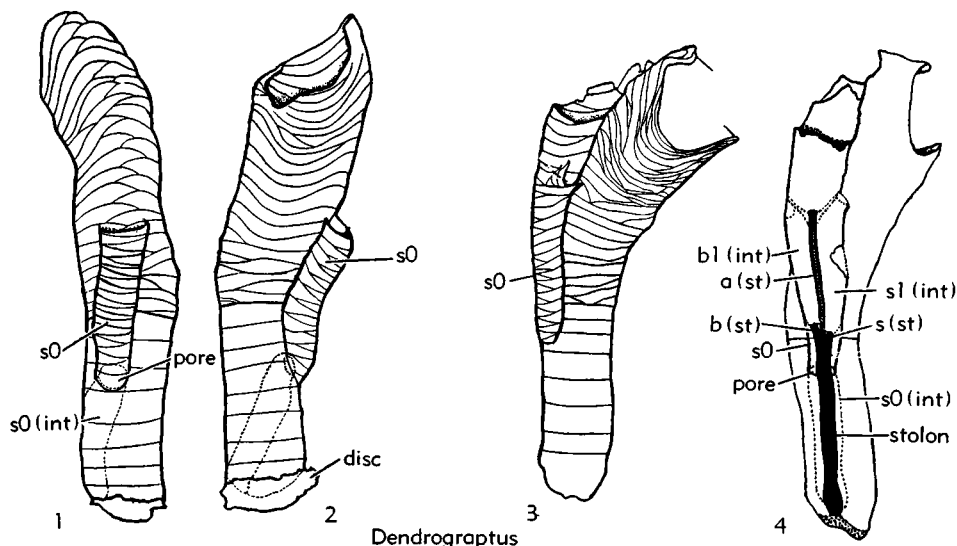

FIG. 13. Sicular and initial bud of *Dendrograptus communis* KOZŁOWSKI (32). 1, 2, Prosicula with basal disc and spiral line, metasicula, and early stage of initial bud (stolothecha, *sO*) which extends internally (*sOint*) to base of prosicula. 3, 4, Later stage of development showing the 3 descendants of stolothecha *O*. (All figs. $\times 45$ approx.; letter symbols as in Fig. 7.)

external characters of the rhabdosome. This may not prove to be a real handicap, for what is now known concerning internal morphology suggests that it is extraordinarily uniform in its essentials throughout the group; and among living cephalodiscids, with all the characters available, subdivision nevertheless is based on general characters of the coenocium. Family grouping must be regarded as provisional only, for it is very possible that certain genera are wrongly placed and it is probable also that many genera may be polyphyletic.

The main features used in generic discrimination include general form of the rhabdosome (conical, flabellate, dendroid, etc.); type of branching (dichotomous or lateral); occurrence of anastomosis or dissepimental connection between adjacent branches; and thecal type (e.g., denticulate, elongate, and tubular, the latter commonly associated with characteristic thecal grouping).

Many species have been described on the basis of poorly preserved fragments which give little indication of rhabdosome form; the validity of most of these is doubtful and even their assignment to well-established genera is often unreliable.

SYSTEMATIC DESCRIPTIONS

Family DENDROGRAPTIDAE Roemer in Frech, 1897

Rhabdosome conical, flabellate or irregularly dendroid, rarely attached by nema, generally with thecate or more or less thickened nonthecate stem terminating in root-like processes or disc of attachment; rarely several rhabdosomes arise from a single stolon. Branching dichotomous, stipes free or united by anastomosis or by transverse dissepiments. Autothecae denticulate to tubular and isolate, commonly with unpaired spinous apertural processes; bithecae variable, usually inconspicuous externally;

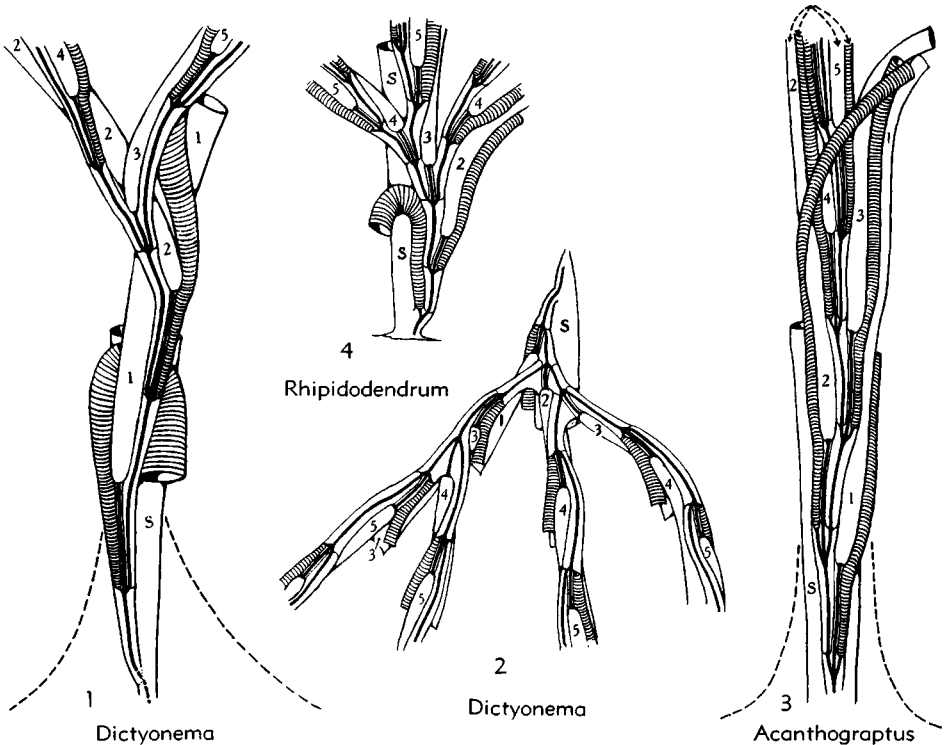

FIG. 14. Diagrams representing development of graptolite rhabdosomes. 1, *Dictyonema cavernosum* WIMAN. 2, *D. flabelliforme* (EICHW.). 3, *Acanthograptus suecicus* (WIMAN). 4, *Rhipidodendrum samsonowiczii* KOZŁOWSKI. (Autothecae numbered in order of appearance; bithecae shaded; stolon system in solid black; sicula, S.)

stolothecae along dorsal side of stipe.
?M.Cam., U.Cam.-L.Carb.

Dendrograptus HALL, 1858 [**Graptolithus hallianus* PROUT, 1851; SD HALL, 1862] [= *Callodendrograptus* DECKER, 1945; ?*Ophiograptus* POULSEN, 1937]. Generally robust, shrublike in habit,

branching irregular, stipes unconnected, usually divergent, stem well developed, with basal attachment; autothecae denticulate, spined or with broad apertural processes, or to some extent tubular and isolate. ?M.Cam., U.Cam.-L.Carb., almost world-wide.—FIG. 15,1a. *D. fruticosus* HALL, L.Ord.(Levis sh.), Que.; ×1 (21).—FIG. 15,1b.

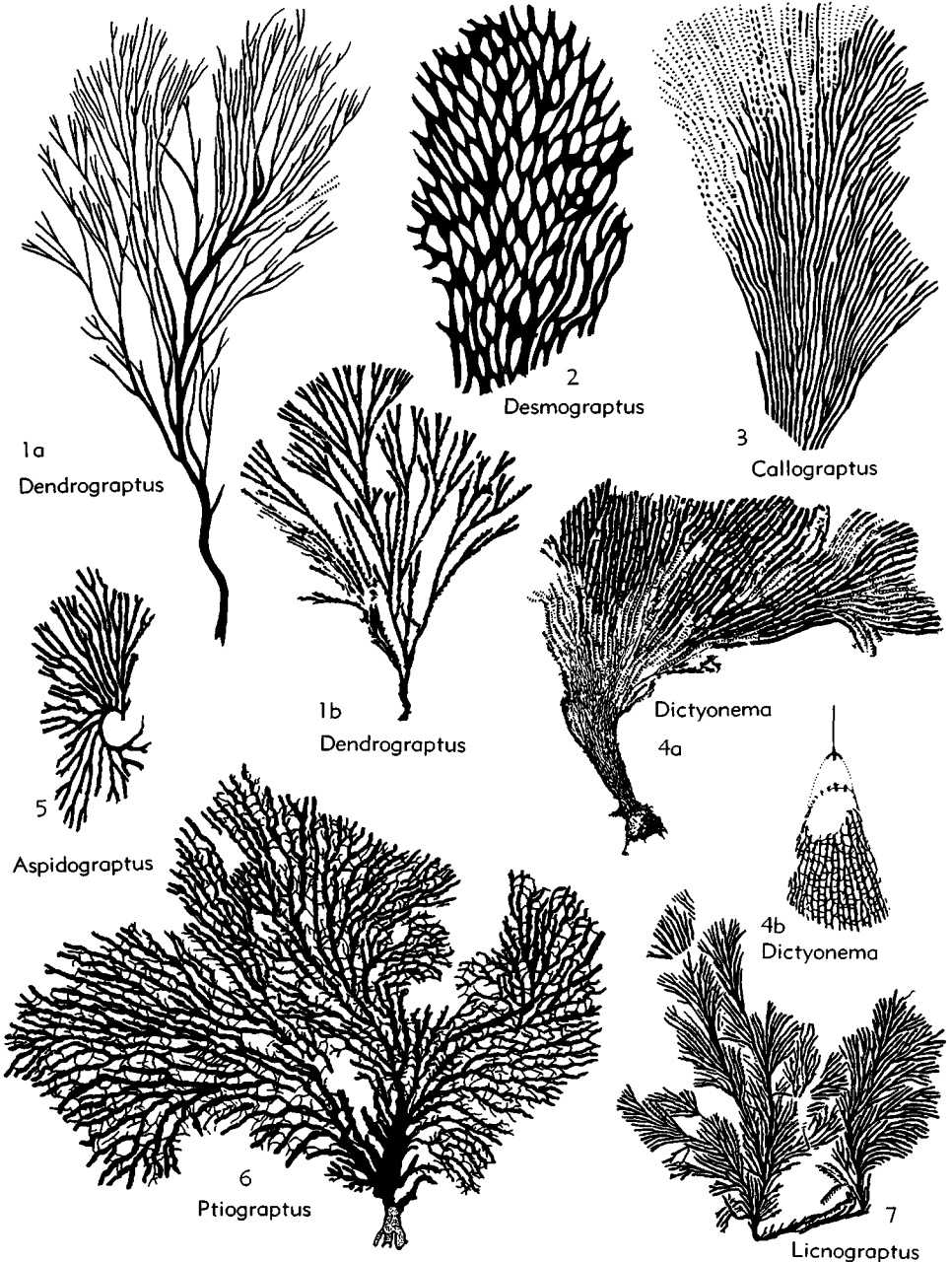

FIG. 15. Dendrograptidae (p. V30-V32).

**D. hallianus*, U.Cam.(Trempeal.), Minn.; $\times 1$ (53).

Aspidograptus BULMAN, 1934 [**Clematograptus implicatus* HOPKINSON, 1875]. Similar to *Dendrograptus* but branching laterally from ?4 curved principal stipes; lateral branches close-set, irregularly produced, bifurcating repeatedly. *U.Cam.-Ord.*, Eu.-N.Am.-S.Am.—FIG. 15,5. **A. implicatus* (HOPKINSON), L.Ord.(Arenig.), Eng.; $\times 1$ (5).

Callograptus HALL, 1865 [**C. elegans*; SD MILLER, 1889] [= *Odontocaulis* LAPWORTH, 1881]. Conical to irregular, with thecate stem (*Odontocaulis* condition) or thickened nonthecate stem; branching dichotomous with some regularity, stipes subparallel to parallel, rarely united by dissepiments or anastomosis; autothecae commonly more or less tubular, but rarely isolate. *U.Cam.-L.Carb.*, almost world-wide.—FIG. 15,3. *C. salteri* HALL, L.Ord.(Levis), Que.; $\times 1$ (21).

Desmograptus HOPKINSON, 1875 [**Dictyograptus cancellatus* HOPKINSON, 1875] [= *Rhizograptus* SPENCER, 1878; *Rhizograptus* SPENCER, 1884 (*nom. van.*)]. Conical, possibly rarely flabellate, stipes flexuous, united by regular anastomosis and rare dissepiments; autothecae commonly tubular, but rarely isolate. *Ord.-L.Carb.*, Eu.-N.Am.—FIG. 15,2. **D. cancellatus* (HOPKINSON), L.Ord.(Arenig.), S.Wales; $\times 1$ (79).

Dictyonema HALL, 1851 [**Gorgonia? retiformis* HALL, 1843; SD MILLER, 1889] [= *Phyllograptia* ANGELIN, 1854; *Rhadinopora* EICHWALD, 1855; *Graptopora* SALTER, 1858; *Dictyograptus* HOPKINSON, 1875; *Damesograptus* JAHN, 1892; *Dictyodendron* (obj.), *Dictyograptus* WESTERGÅRD, 1909; *Airograptus* RUEDEMANN, 1916; *Nephelograptus* RUED., 1947]. Conical, varying from cylindrical to almost discoidal, with thecate or nonthecate stem, or rarely attached by nema; branching dichotomous, usually regular, stipes straight, subparallel to parallel, united by transverse dissepiments, anastomosis rare or absent; autothecae denticulate, commonly spined, rarely tubular and isolate. *U.Cam.-L.Carb.*, almost world-wide.—FIG. 15,4a. *D. crassibasale* BASSLER, M.Sil.(Niag.), Hamilton, Ont.; $\times 1$ (71).—FIG. 15,4b. *D. flabelliforme* (EICHWALD), L.Ord.(Tremadoc.), Pedwardine, Eng.; $\times 1$ (5).

Licnograptus RUEDEMANN, 1947 [**L. elegans*]. Several principal branches bearing fanlike groups of subparallel branches laterally and distally; thecal details unknown. *L.Ord.*, Que.-Newf.—FIG. 15,7. **L. elegans*, Levis sh., Que.; $\times 1$ (53).

Marsipograptus RUEDEMANN, 1936 [**M. bullatus*] [= *Marsipograptus* ULRICH & RUED., 1931 (*nom. nud.*)]. Like *Desmograptus* but with spherical appendages (?bithecae) developed irregularly along branches; thecal details unknown. *Ord.*, ?*Sil.*, Tenn.-Que.

Ptiograptus RUEDEMANN, 1908 [**P. percorrugatus*]. Like *Dictyonema* but rhabdosome flabellate; dis-

sepiments irregular, commonly angular; thecal details unknown. *Sil.-L.Carb.*, N.Am.-NW.Eu.—FIG. 15,6. **P. percorrugatus*, M.Dev., Ky.; $\times 1$ (50).

Reticulograptus WIMAN, 1901 [**Dictyonema tuberosum* WIMAN, 1895]. Like *Dictyonema* but with rare dissepiments and frequent anastomosis; autothecae and bithecae elongate, tubular; stipes commonly compound (more than one chain of stolothecae). *Ord.-Sil.*, N.Am.-NW.Eu.

Rhipidodendrum KOZLOWSKI, 1949 [**R. samsonowiczii*]. Flabellate, branching irregularly from 3 primary branches; autothecae and bithecae tubular, rather strongly curved. *L.Ord.(Tremadoc.)*, Pol.

Syrhripidograptus POULSEN, 1924 [**S. nathorstii*]. Like *Desmograptus*, probably conical, branching irregular, stipes anastomosing without dissepiments; thecae tubular, isolate, bithecae and stolothecae unknown; several rhabdosomes from a creeping stolon. *Ord.M.(Dicellogr. sh.)*, NW.Eu.

Family ANISOGRAPTIDAE Bulman, 1950

Rhabdosome siculate, pendant to horizontal or slightly reclined quadriradiate, triradiate or bilateral; branching usually dichotomous, rarely lateral; stipes typically of dendrograptid structure, autothecae and bithecae characteristically simple, latter reduced in some. *L.Ord.(incl. Tremadoc.)*.

Anisograptus RUEDEMANN, 1937 [**A. matanensis*]. Rhabdosome triradiate, developed by dichotomous division to 6th order (usually 3rd or 4th) from 3 primary branches; typically horizontal, but including declined and slightly reclined forms; triad branch structure characteristic, autothecae denticulate, bithecae short, simple. *L.Ord.(Tremadoc.)*, NW.Eu.-Can.-S.Am.—FIG. 16,4. **A. matanensis*, Que.; $\times 1$ (72).

Adelograptus BULMAN, 1941 [**Bryograptus? hunnebergensis* MOBERG, 1892]. Usually declined or almost horizontal, rarely pendent, commonly somewhat lax and flexuous, developed from 2 primary stipes by infrequent and irregular branching apparently lateral rather than dichotomous; autothecae denticulate, stolothecae and bithecae in early species. *L.Ord.(incl. Tremadoc.)*, NW.Eu.-N.Z.-Austral.—FIG. 16,3. **A. hunnebergensis* (MOBERG), Eng.(Shrops.), $\times 1$ (54).

Bryograptus LAPWORTH, 1880 [**B. kjerulfi*; SD GURLEY, 1896]. Rhabdosome pendent to declined, developed from 3 main stipes by irregular and apparently lateral branching; stolothecae and bithecae apparently present in early species. *L.Ord.(incl. Tremadoc.)*, NW.Eu.-N.Am.-Austral.-?Greenl.—FIG. 16,2a. **B. kjerulfi*, Tremadoc.—FIG. 16,2b. *B. patens* Matthew, *L.Ord.(Tremadoc.)*, Que.; $\times 1$ (72). S.Swed.; $\times 1$ (72).

Clonograptus HALL & NICHOLSON, 1873 [**Graptolithus rigidus* HALL, 1858; SD MILLER, 1889] [= ?*Herrmannograptus* MONSEN, 1937]. Rhabdo-

some bilateral, produced by regular dichotomous division at steadily increasing intervals to 8th or 9th order (usually 5th or 6th); rigidly diverging proximally, becoming subparallel and in some flexuous distally; autothecae usually denticulate with moderate inclination, some with low inclination and negligible overlap, some with exaggerated spines; stolothecae and bithecae in early

species. Central disc rare. (In view of the variability of *Clonograptus*, it seems scarcely possible to maintain *Herrmannograptus* MONSEN, 1937, as a distinct genus.) *L.Ord.*(incl. *Tremadoc.*), almost world-wide.—FIG. 16,1a. **C. rigidus* (HALL), Levis sh., Que.; $\times 0.5$ (76).—FIG. 16,1b. *C. tenellus* LINNARSSON, Tremadoc., S.Swed., $\times 1$ (94). [*Clonograptus* = *nom. correct.* LAPWORTH, 1873 (*pro Clonograpsus* HALL & NICH., 1873) *nom.*

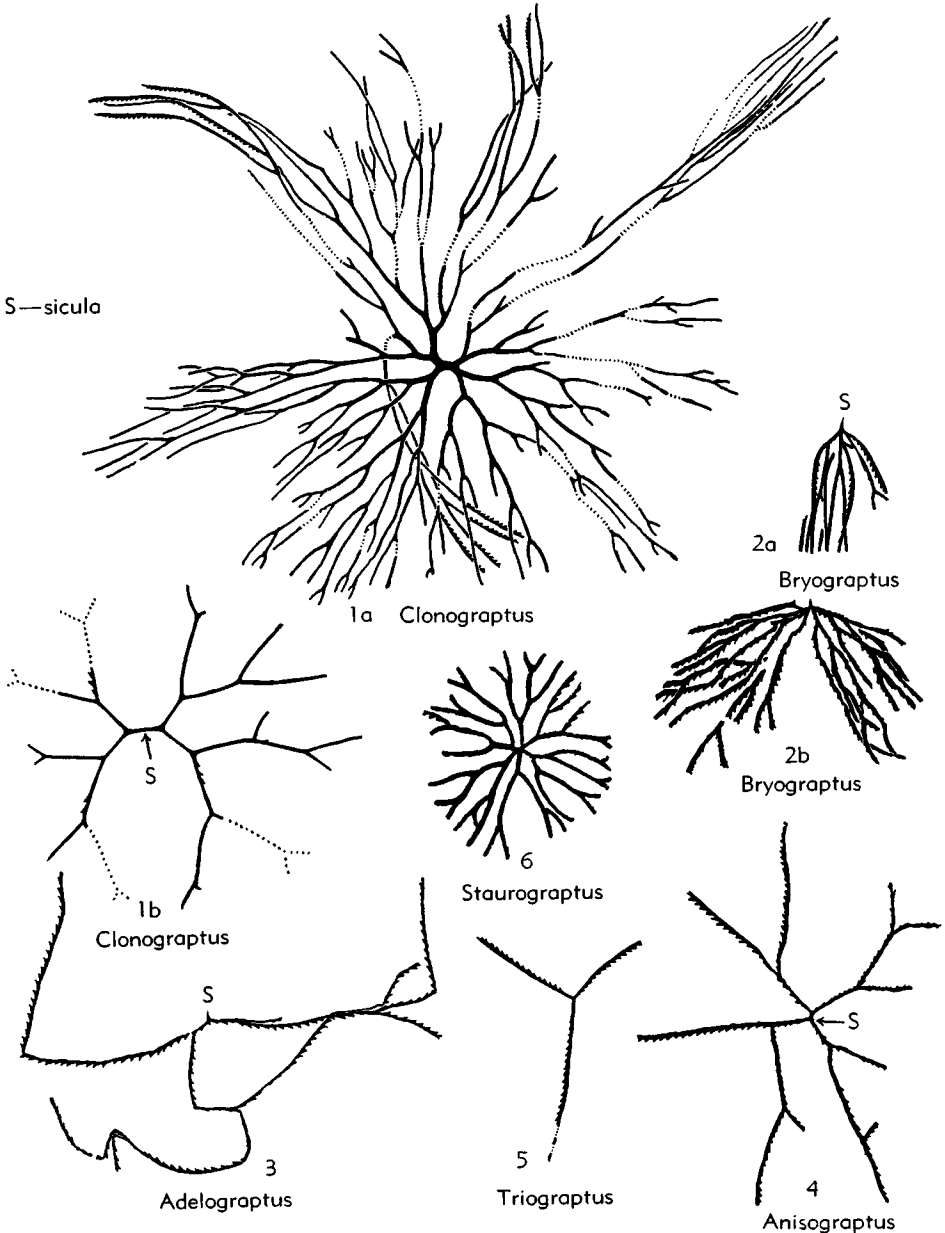

FIG. 16. Anisograptidae (p. V32-V34).

conserv. proposed BULMAN, 1955, ICZN pend.]

Radiograptus LAPWORTH MS in BULMAN, 1950 [**R. rosieranus*]. Rhabdosome triradiate, discoidal, composed of numerous branches connected by sparsely developed dissepiments; thecal structure imperfectly known. *L.Ord.*(*Tremadoc.*), Can.

Staurograptus EMMONS, 1855 [**S. dichotomus*]. Small, quadriradiate, developed by dichotomous division to 4th order of 4 primary branches, typically horizontal; triad branch structure char-

acteristic. *L.Ord.*(*Tremadoc.*), N.Am.-Austral.-?NW.Eu.—FIG. 16,6. **S. dichotomus*, Schaghticoke sh., N.Y.; $\times 1$ (50). [*Staurograptus* = *nom. correct.* HALL, 1865 (*pro Staurograptus* EMMONS, 1855) *nom. conserv.* proposed BULMAN, 1955, ICZN pend.]

Triograptus MONSEN, 1925 [**T. osloensis*]. Rhabdosome triradiate composed of 3 more or less horizontal, undivided stipes; stolothecae probably and bithecae possibly present. *L.Ord.*(*Tremadoc.*),

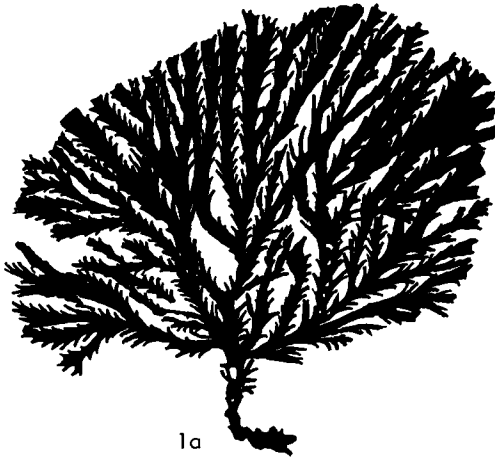

1a
Acanthograptus



1b
Acanthograptus



2a
Koremagraptus

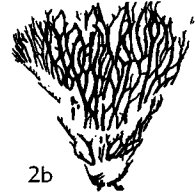

2b
Koremagraptus

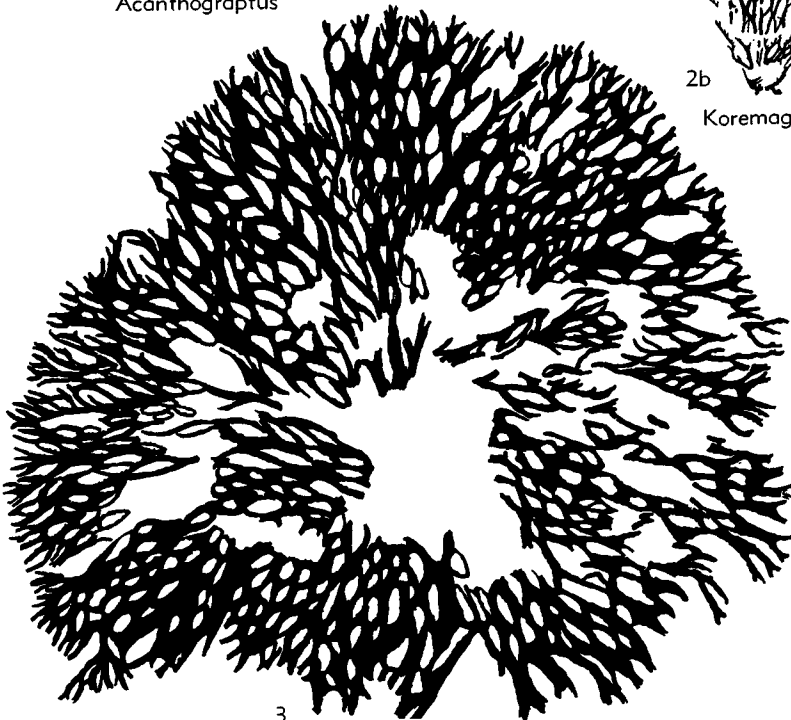

3
Palaeodictyota

NW.Eu.-N.Z.-Can.—FIG. 16,5. *T. canadensis*
BULMAN, Que.; $\times 1$ (72).

Family ACANTHOGRAPTIDAE
Bulman, 1938

Rhabdosome benthonic, conical to irregu-

larly dendroid; stipes flexuous and anastomosing or rigid and bifurcating, composed of elongate tubular thecae adnate for most of their length, produced in triads but commonly showing characteristic grouping; stipes compound in many, with more than

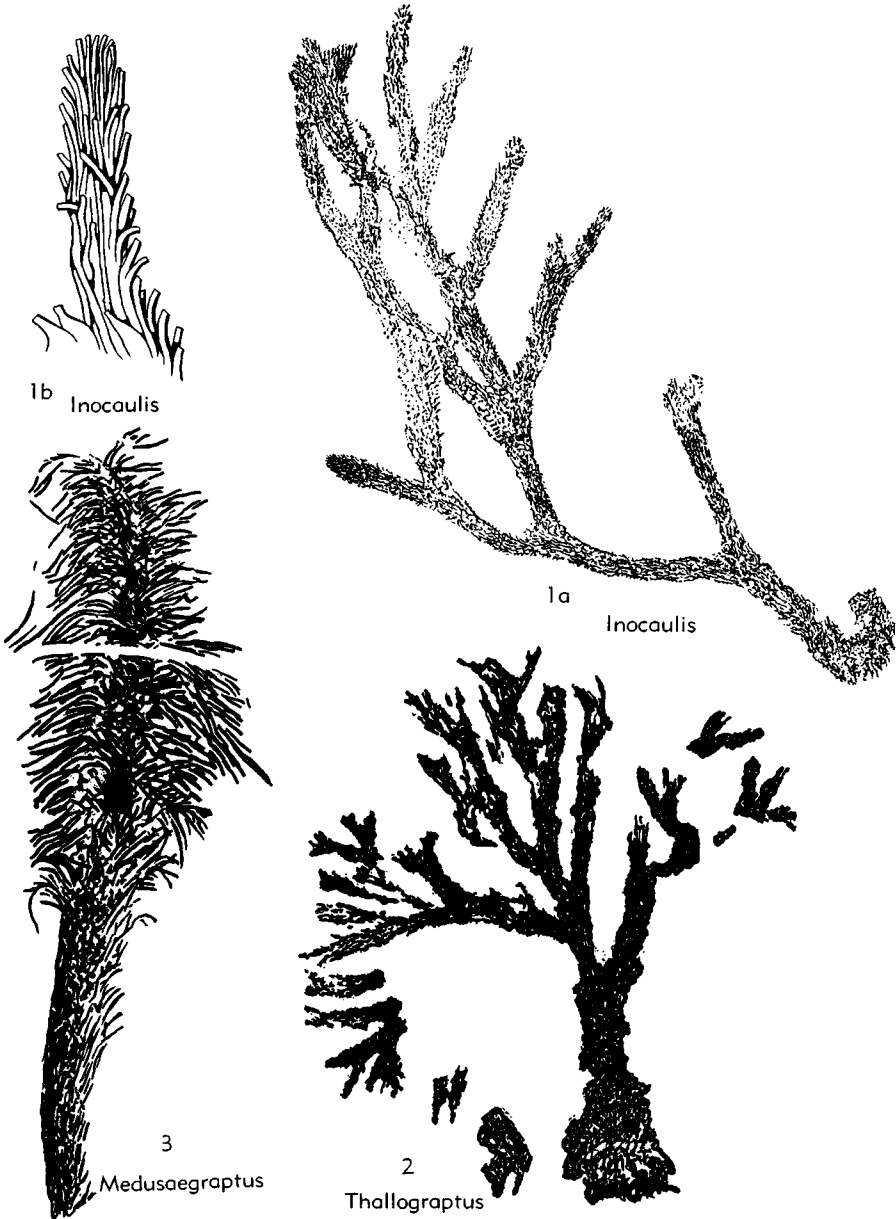

FIG. 18. Inocaulidae (p. V36).

one chain of stolothecae. ?*U.Cam., M. Ord.-U.Sil.*

Acanthograptus SPENCER, 1878 [**A. granti*]. Robust dendroid composed of rather stout branches which bifurcate irregularly and usually do not diverge strongly; thecae elongate tubular, usually isolate distally to give spinous appearance to branch; grouping of autothecae and bithecae in "twigs" is characteristic. ?*U.Cam., Ord.-Sil.*, Eu.-N.Am.-?Asia-?Austral.—FIG. 17,1a. **A. granti*, M.Sil.(Niag.), Ont.; $\times 1$ (50).—FIG. 17,1b. *A. musciiformis* (WIMAN), U.Ord., Balt.; distal part of branch, $\times 7$ (70). [*Acanthograptus* = *nom. correct.* SPENCER, 1884 (pro *Acanthograptus* SPENCER, 1878) *nom. conserv.* proposed BULMAN, 1955, ICZN pend.]

Koremagraptus BULMAN, 1927 [**K. onniensis*]. Conical, branches complex, with branches and twigs anastomosing irregularly. *U.Ord.-M.Dev.*, Eu.—FIG. 17,2b. **K. onniensis*, L.Sil., Eng. (Shrops.), $\times 1$ (72).—FIG. 17,2a. *K. kozlowskii* BULMAN, M.Ord., S.Scot.; specimen showing tubular thecae and irregular twigs, $\times 6$ (9).

Palaeodictyota WHITFIELD, 1902 [**Inocaulis anastomotica* RINGUEBERG, 1888]. Like *Koremagraptus* but with thecae adnate throughout their length, opening as pores on surface. *Sil.*, N.Am.—FIG. 17,3. **P. anastomoticus* (RINGUEBERG), Rochester sh., N.Y.; $\times 1$ (50).

Family INOCAULIDAE Ruedemann, 1947

Generally similar to *Acanthograptidae* but with extremely fine filamentous thecal tubes. *Ord.-Sil.*

Inocaulis HALL, 1851 [**I. plumulosa*]. Very thick branches that bifurcate infrequently, abundant fine thecal tubes projecting distally as hairlike processes. *Ord.-Sil.*, N.Am.-?Eu.—FIG. 18,1. **I. plumulosa*, M.Sil.(Niag.), Ont.; 1a, rhabdosome, $\times 1$ (71); 1b, fragment of distal part of branch, $\times 5$ (50).

Thallograptus RUEDEMANN, 1925 [*non* ÖPIK, 1928] [**Dendrograptus? succulentus* RUED., 1904]. Like *Acanthograptus* but with more numerous and more slender thecae, the isolate parts of which are preserved rarely. *Ord.-Sil.*, N.Am.—FIG. 18,2. **T. succulentus* (RUED.), Sil.(Rochester sh.), N.Y.; $\times 1$ (88).

?**Diplospirograptus** RUEDEMANN, 1925 [**D. goldringae*]. Stem composed of 2 spirally twisted branches from which brushlike aggregate of short tubular branches is given off distally (possibly algal). *Sil.*, N.Am.

?**Medusagraptus** RUEDEMANN, 1925 [**M. mirabilis*]. Thick main branch ending in blunt point at base and terminating distally in dense mass of slender unbranched flexuous tubes (possibly algal). *Sil.*, N.Am.—FIG. 18,3. **M. mirabilis*, Lockport dol., N.Y.; $\times 1$ (88).

Family PTILOGRAPTIDAE Hopkinson, 1875

Rhabdosome dendroid, with alternating pinnate arrangement of lateral branches. *L.Ord.-U.Sil.*

Ptilograptus HALL, 1865 [**P. plumosus*; SD MILLER, 1889] [= *Denticulograptus* SCHMIDT, 1939]. Rhabdosome with comparatively few main branches, bifurcating infrequently and bearing close-set lateral branches arranged alternately on opposite sides; autothecae usually denticulate but thecal details unknown. *L.Ord. (Arenig.)-U.Sil.*, Eu.-N.Am.-Austral.—FIG. 19,1a. **P. plumosus*, *L.Ord. (Levis sh.)*, Que.; $\times 1$ (21).—FIG. 19,1b. *P. delicatulus* RUEDEMANN, *Ord. (Ottosee sh.)*, Tenn.; $\times 1$ (53).

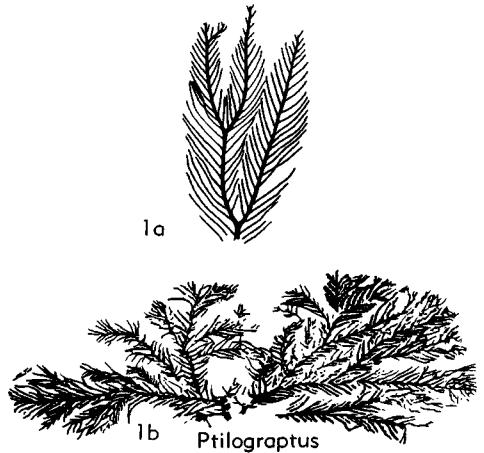

FIG. 19. Ptilograptidae (p. V36).

Family CHAUNOGRAPTIDAE Bulman, nov.

Free dendroid or irregularly branched encrusting rhabdosomes with free conical thecae. *Cam.-Dev.*

Chaunograptus HALL, 1883 [**Dendrograptus (Chaunograptus) novellus*] [= *Thallograptus* ÖPIK, 1928 (*non* RUEDEMANN, 1925); *Hormograptus* ÖPIK, 1930]. Minute dendroid rhabdosomes usually encrusting foreign bodies (as shells) with short conical thecae. ?*Cam. (N.Am.)*, *Ord. (Eu.-N.Am.)-Dev. (N.Am.)*.—FIG. 20,2. *C. conortus* RUED., *U.Ord. (Richmond.)*, Ind.; $\times 3.5$ (53).

Mastigograptus RUEDEMANN, 1908 [**Dendrograptus tenuiramosus* WALCOTT, 1883]. Slender dendroid rhabdosomes with rather irregularly developed conical thecae. *Cam.-Ord.*, ?*Sil.*, N.Am.-S.Am.

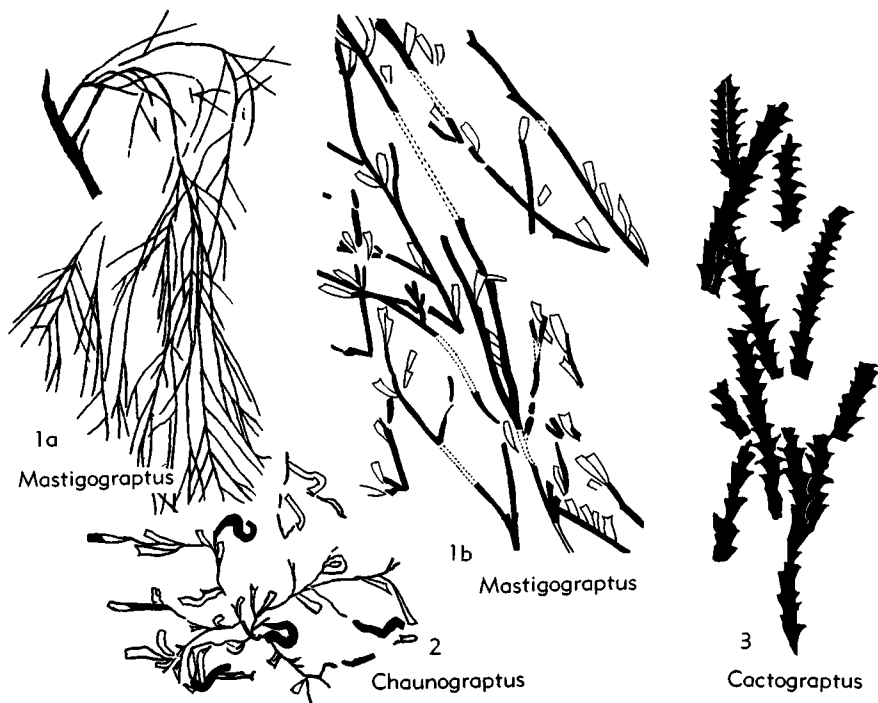

FIG. 20. Chaunograptidae (p. V36-V37).

Austral.—FIG. 20,1. **M. tenuiramosus* (WALC.); 1a, rhabdosome, Ord.(Utica sh.), N.Y., $\times 1$ (50); 1b, fragment showing thecae, Ord.(Eden sh.), Ky., $\times 5$ (50).

?*Ascograptus* RUEDEMANN, 1925 [**A. similis*]. Relatively large conical thecae arranged spirally along unbranched stipe. *Sil.*, N.Am.

?*Haplograptus* RUEDEMANN, 1933 [**H. wisconsinensis*]. Elongate conical or vermiform thecae associated to form an irregularly dendroid rhabdosome. *Cam.-Ord.*, N.Am.

?Order DENDROIDEA Incertae Sedis

Cactograptus RUEDEMANN, 1908 [**C. crassus*].

Apparently dendroid, composed of thick biserial stipes. ?*Cam.* (Austral.), *Sil.* (N.Am.).—FIG. 20,3. **C. crassus*, *Sil.* (Clinton.), N.Y.; $\times 1$ (50). *Ceramograptus* HUDSON, 1915 [**C. ruedemanni*]. Stipes apparently multiserial. *Ord.* (Trenton.), Can. *Coelograptus* RUEDEMANN, 1947 [**Inocaulis problematica* SPENCER, 1878]. Rhabdosome encrusting, irregularly branching; rarely anastomosing, thecae unknown. *Sil.*, Can.

Ruedemannograptus TERMIER, 1948 [*pro Streptograptus* RUEDEMANN, 1947 (non YIN, 1937)] [**Streptograptus rectangularis* RUEDEMANN, 1947; SD BULMAN, herein]. Irregularly dendroid, apparently biserial or multiserial. *Ord.*, N.Am.

TUBOIDEA

Order TUBOIDEA Kozłowski, 1938

[Introduced by KOZŁOWSKI in 1938 without diagnosis but descriptive notes in text; defined by BULMAN (8) in 1938 but first adequately described by KOZŁOWSKI (32) in 1949]

Sessile Graptolithina with erect stipes and more or less dendroid rhabdosome, or encrusting with terminally erect thecae or groups of thecae; stolothecae not well individualized, or confined to encrusting basal disc (thecorhiza); autothecae and bithecae both present, but budding capricious, diad

in some, usually obeying no fixed rule, spacing of nodes variable. *L.Ord.* (*Tremadoc.*)-*Sil.*

In common with the Dendroidea, the Tuboidea are characterized by presence of the same 3 types of individuals, but their association and arrangement is far less regular and the stolothecae are less clearly individualized. They comprise 2 families, so distinct that it is convenient to describe their morphology separately.

Family TUBIDENDRIDAE Kozłowski,
1949

Rhabdosome erect, ?flabellate; stipes dividing irregularly and united by single thecae or anastomosing, comprising at any given level numerous thecae of several generations; stolothecae more or less embedded in stipe, variable in length, with no regular budding rhythm; autothecae spirally coiled in their middle portion (helicothecal), dimorphic, one form (microthecae) with narrow contracted apertural portion; bithecae with relatively long bithecal stolons; stolon system well developed, highly chitinized. *L.Ord.*(*Tremadoc.*).

The family is represented at present by the single monotypic genus *Tubidendrum* and the above diagnosis must be regarded as provisional.

MORPHOLOGY

The material is so fragmentary that determination of the shape of the rhabdosome is uncertain, but it seems to have been either flabellate or conical. Branches are united by anastomosis or are connected by thecae (especially bithecae) which pass from one to another; most of the autothecae and many bithecae open on one (pinner) side. The spacing and distribution of thecal apertures along the stipe is irregular. The proximal end and mode of development are unknown.

Stolothecae. The stolon system is well developed, the stolons possessing thick chitinized walls and being strongly pigmented. The stolothecae themselves, however, are not well differentiated and are commonly enveloped in the sheaf of thecae constituting a stipe, instead of occupying the external position characteristic of most Dendroidea. Division at the stolonal nodes is usually into 2 (Fig. 21) in manner associating any pair of thecae except 2 autothecae; thus using *a* for autotheca, *b* for bitheca, and *s* for stolotheca, pairs formed by division may be *ab*, *as*, *bb*, *bs*, or *ss*. As in complex dendroids like "*Desmograptus formosus*" (p. V26), bifurcation of a branch is not immediately related to stolonal division ("branching division" of the Dendroidea).

Autothecae. The autothecae are elongate and tubular, chiefly remarkable for the coiling of their central portions into a helical spiral with some 7 or more turns. This coil-

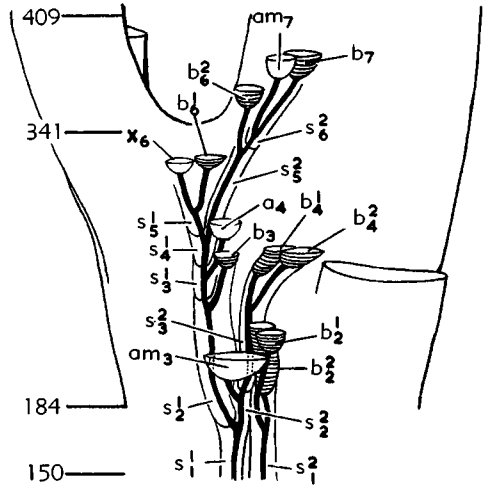

FIG. 21. Stolon system of *Tubidendrum* (solid black, with bases only of daughter thecae) reconstructed from and lettered as in serial sections figured by Kozłowski (32, pl. 21) (stolothecae, *s*; autothecae, *a*, and microthecae, *am*; bithecae, *b*; sections 150-409).

ing, either right- or left-handed, is so tight as to produce a "columella" analogous to that of a turreted gastropod. In one measured example, the autothecal stolon was 175 microns long, the proximal portion of the autotheca 1,315 microns, the coiled portion measured along the axis 620 microns, and the straight distal portion 250 microns.

Dimorphism in the autothecae themselves exists also, one type (called microthecae) having a narrow terminal portion about $\frac{1}{3}$ the diameter of a normal autotheca, with an oblique aperture. Moreover, their ventral surface (as defined by the apertural process) faces the opposite side of the branch to that of normal autothecae. In other respects, the form and dimensions are comparable.

Bithecae. The bithecae are slightly narrower but of similar length to the autothecae. As compared with the Dendroidea, they possess unusually long stolons, though the actual stolonal length varies within wide limits. Their distribution along the branch and their position in relation to the autothecae are also variable. Commonly they open in the angle formed between the isolated distal part of an autotheca and the rest of the branch; but they also constitute "pseudodissepiments," opening on a branch in which they did not originate.

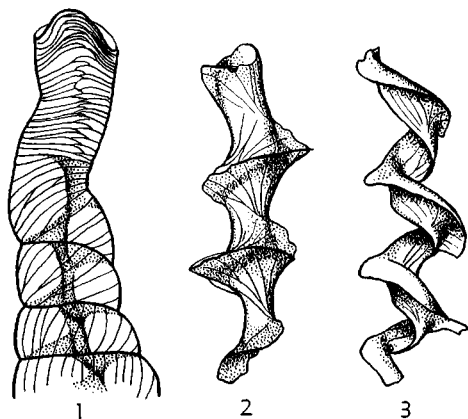

FIG. 22. Structural features of *Tubidendrum* (32). 1, Coiled and distal portions of an autotheca, $\times 40$. 2, 3, Examples of columella from the helicoidal parts of 2 autothecae, $\times 90$.

SYSTEMATIC DESCRIPTION

Tubidendrum KOZŁOWSKI, 1949 [**T. bulmani*].
Only genus. *L.Ord.*(*TremaDoc.*), Pol.—FIG. 22, 1. **T. bulmani*; 1a, autotheca, $\times 40$; 1b,c, columellae, $\times 90$ (32).

Family IDIOTUBIDAE Kozłowski, 1949

Rhabdosome an encrusting assemblage of thecae (thecorhiza) from which arise tubular autothecae singly or in groups; stolothecae confined to thecorhiza; initial portion of autothecae horizontal, incorporated in thecorhiza, distally tubular, erect; bithecae limited to thecorhiza or extending beyond it in association with bases of autothecae or groups of autothecae. *Ord.-Sil.*

MORPHOLOGY

The rhabdosome, more or less discoidal in shape, consists of an irregular encrusting mass of thecae, called the thecorhiza, from the upper surface of which arise the tubular distal extremities of the autothecae either singly or in groups or bundles.

Stolothecae. Owing to the fragmentary condition of the Polish material described by KOZŁOWSKI and the less perfect preservation of more complete rhabdosomes of later genera such as *Cyclograptus*, the proximal end, mode of development, and full details of the stolothecae are unknown. The stolothecae are confined to the thecorhiza, and traces visible in fragments of *Idiotubus* and others suggest that as in the Tubidendridae probably they are not very well differentiated

and are variable in length, with no regular budding rhythm.

Autothecae. Each autotheca comprises 2 distinct portions, a proximal adnate part incorporated in the thecorhiza and an erect distal part, free or associated in a sheaf with other autothecae. Probably simply because both organisms are encrusting, the general characters are not unlike those of *Rhabdopleura*. The basal portion incorporated in the thecorhiza consists of regular growth bands of fusellar tissue on its upper surface, but the lower surface is structureless. The free portion, however, is composed of regular growth bands disposed right and left, forming 2 (dorsal and ventral) zigzag sutures; and rounded apertural processes are commonly developed. At the base of the free portion, the autothecae may show some helical coiling (e.g. *Dendrotubus*) comparable on a smaller scale with that of *Tubidendrum*.

Bithecae. The bithecae are mainly distinguished from the autothecae by their smaller diameter and in general are limited to the thecorhiza.

Form of rhabdosome and thecal grouping. There is a graded series from *Idiotubus* with autothecae arising singly from the upper surface of the thecorhiza, through *Dendrotubus* and *Discograptus* with the autothecae concentrated in groups, to *Galeograptus* and *Cyclograptus* with a peripheral concentration of large sheaves of autothecae and bithecae. The same series illustrates also a progressive increase in regularity with which the thecae are distributed. In *Idiotubus*, the erect portions of the autothecae appear to have been distributed quite haphazardly over the surface of the thecorhiza; and in *Dendrotubus* the arrangement is usually irregular but with a tendency toward greater regularity at distal ends of the thecal bundles. In *Discograptus* the thecal groups are arranged more definitely along several radii, steadily increasing in height peripherally, whereas in *Galeograptus* and *Cyclograptus* the stipes are confined to the periphery and composed of very numerous thecae, the bithecal apertures being concentrated around their bases or (in *Galeograptus*) occurring on the branches themselves. Differences in the stolonial systems underlying these varied groupings are at present unknown.

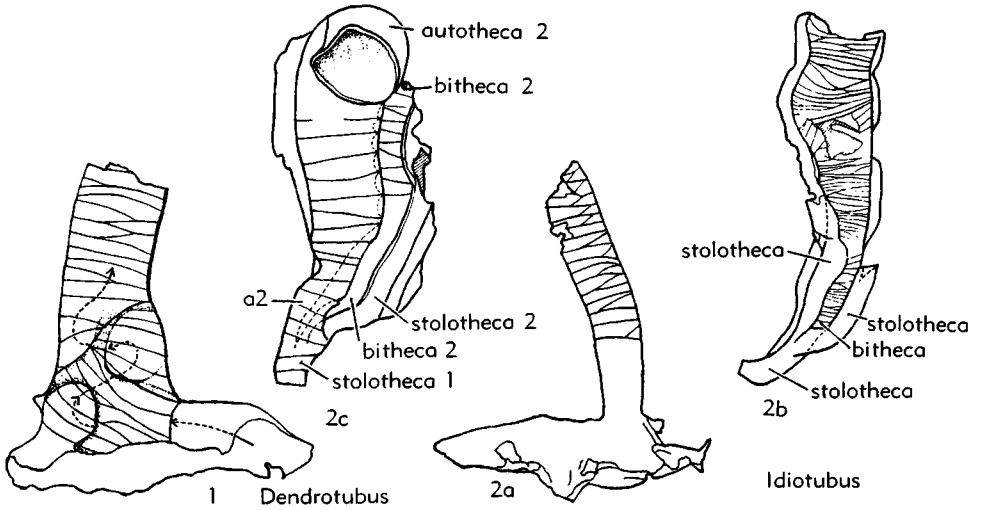

FIG. 23. Idiotubidae (p. V40-V41).

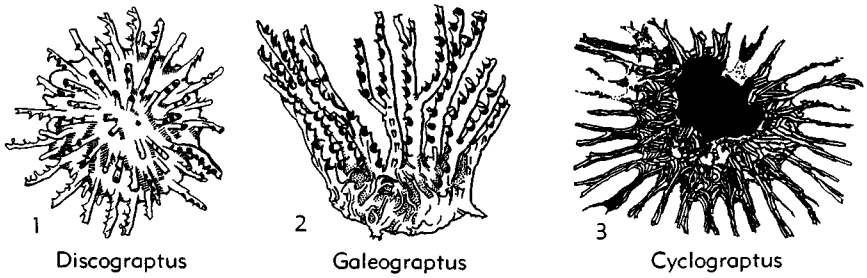

FIG. 24. Idiotubidae (p. V40-V41).

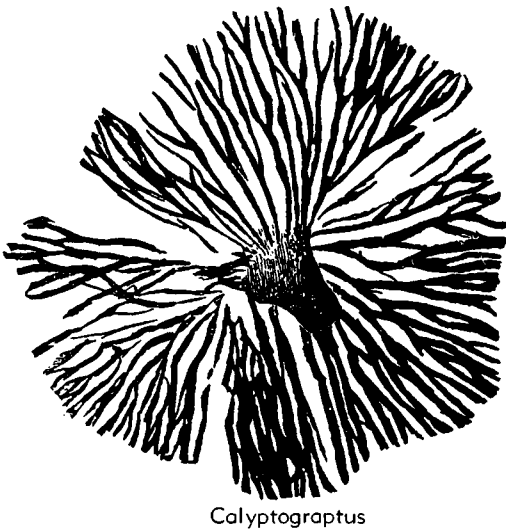

FIG. 25. Idiotubidae (p. V41).

SYSTEMATIC DESCRIPTIONS

Idiotubus KOZŁOWSKI, 1949 [**I. typicalis*]. Irregularly distributed, erect portions of the autothecae arising singly from surface of the corrhiza. *L.Ord.* (*Tremadoc.*), Pol.—FIG. 23,2. *Idiotubus* sp.; 2a, autotheca and fragment of the corrhiza, $\times 25$; 2b, bitheca with stolothecae, $\times 25$; 2c, autotheca with associated bitheca and stolothecae, $\times 50$ (32). *Calycotubus* KOZŁOWSKI, 1949 [**C. infundibulatus*]. Autothecae fused by their lateral walls into irregular groups. *L.Ord.* (*Tremadoc.*), Pol. *Conitubus* KOZŁOWSKI, 1949 [**C. siculoides*]. Known only by conical autothecae; may be compared with *Protistograptus* McLEARN and some Chaunograptidae. *L.Ord.* (*Tremadoc.*), Pol. *Cyclograptus* SPENCER, 1883 [**C. rotadentatus*]. Rhabdosome discoidal, erect portions of autothecae grouped in 20 to 30 peripheral sheaves bifurcating at their mid-length. *M.Sil.* (*Niag.*), N.Am.—FIG. 24,3. **C. rotadentatus*, Hamilton, Can.; $\times 2$ (72).

- Dendrotubus** KOZŁOWSKI, 1949 [**D. wimani*]. Erect portions of autothecae forming irregularly distributed groups, central portions commonly coiled in helical spiral. *L.Ord.*(*Tremadoc.*), Pol.—FIG. 23, I. **D. wimani*; basal part of autotheca showing spiral coiling; $\times 65$ (32).
- Discograptus** WIMAN, 1901 [**D. schmidti*]. Rhabdosome discoidal, erect portions of autothecae in more or less regular radially arranged groups on upper surface; bithecae confined to thecorhiza. *L.Sil.*(?*Borkholm*), Balt.—FIG. 24, I. **D. schmidti*, Gotl.; $\times 3$ (70).
- Galeograptus** WIMAN, 1901 [**G. wennersteni*]. Rhabdosome discoidal, erect portions of autothecae associated in comparatively few (9, 10) peripheral branches bifurcating usually once near mid-length; bithecae extending along branches. *L.Sil.*(?*Borkholm*), Balt.—FIG. 24, 2. **G. wennersteni*, Gotl.; $\times 3$ (70).
- ?**Calyptragraptus** SPENCER, 1878 [*nom. correct.* SPENCER, 1884 (*pro Calyptragraptus* SPENCER, 1878) BULMAN, 1955, ICZN pend.] [**C. cyathiformis*; SD MILLER, 1889]. Rhabdosome broadly conical, with numerous bifurcating branches united at their base to a thick stemlike structure. *M.Sil.*(*Niag.*), N.Am.—FIG. 25. **C. cyathiformis*, Hamilton, Can.; $\times 1$ (71).
- ?**Epigraptus** EISENACK, 1941 [**E. bidens*]. Similar to *Idiotubus*. *Ord.*(*D₁*), Est.
- ?**Rhodonograptus** POČTA, 1894 [**R. astericus*]. Stellate rhabdosome with discoidal ?thecorhiza from which radiate numerous undulating, rarely bifurcating, branches. *Sil.*, Bohemia.

CAMAROIDEA

Order CAMAROIDEA Kozłowski, 1938

[Introduced by KOZŁOWSKI in 1938 without diagnosis but descriptive notes in text; defined by BULMAN (8) in 1938 but first adequately described by KOZŁOWSKI (32) in 1949]

Encrusting Graptolithina comprising autothecae and indistinct stolothecae, bithecae present in some; autothecae strongly differentiated into 2 parts, an inflated basal vesicle (camara) and a free tubular distal portion (collum); bithecae tubular; stolothecae forming bifurcating network above camarae or represented by extracamara tissue surrounding stolons. *Ord.*

MORPHOLOGY

The shape of the complete rhabdosome is unknown, as is its proximal end and mode of development. As in the Graptoloidea, the dominant element is the autotheca, but chitinized stolons are present invariably, some enclosed in stolothecae, and bithecae characterize one genus.

Autothecae. The autothecae are very sharply differentiated into distinct proximal and distal portions. The camara (proximal portion) is a more or less inflated vesicle or cell, whose upper wall exhibits characteristic fusellar structure in contrast to the lower surface which is structureless; the camarae, commonly embedded in extracamara tissue, form a sort of encrusting mosaic. At the proximal extremity of each is attached the autothecal stolon, separated from the cavity of the camara by one or

more transverse partitions or septa. From one extremity also, although not necessarily the distal one, arises the slender tubular collum, which is morphologically equivalent to the free portion of the autotheca in the Tuboidea. Its wall shows a somewhat irregular fusellar structure and terminates in an apertural process (corresponding to the ventral process of Tuboidea and other graptolites) or more typically thins out distally to terminate in a sharp jagged edge; it has been suggested that this latter feature indicates a gradual transition in life from the chitinous thecal wall into the soft skin of the zooid. Rarely (as in *Cysticamara accollis*), the collum is absent altogether and the thecal aperture is situated on the upper surface of the camara. Occlusion of the autothecae by a chitinous diaphragm, generally near the base of the collum, is of very common occurrence.

Bithecae. Where present (*Bithecocamara*), the bithecae are relatively inconspicuous tubular thecae (as in Tuboidea) which are distributed irregularly and unevenly on or near the surface of the colony.

Stolon system. Stolothecae are present in some genera (*Bithecocamara*) as a bifurcating network of tubes near the upper surface of the colony, and even here they are never very clearly differentiated; in other genera, a stolon system occurs more or less embedded in extracamara tissue which forms a sort of sheath, perhaps representing modified vestiges of original stolothecae. Apart from bifurcations of the stolons (and a corres-

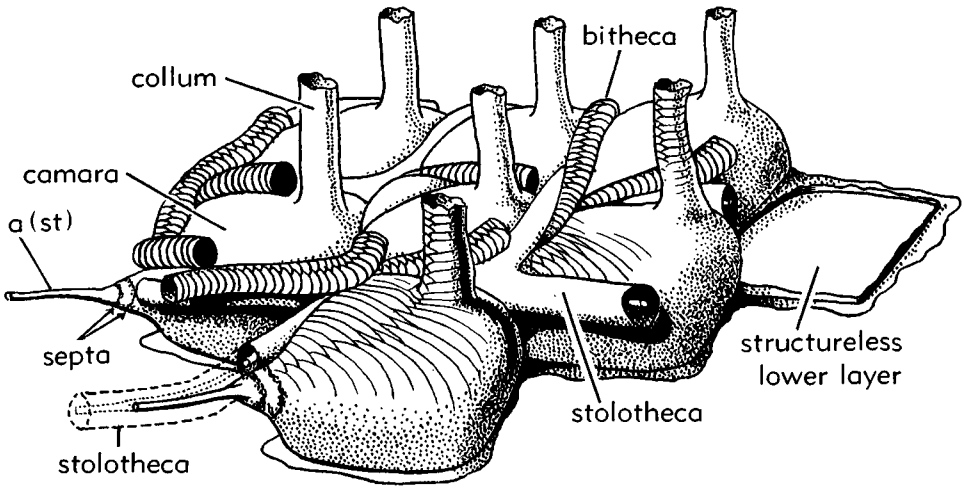

FIG. 26. Diagrammatic restoration of a camaroid, based on *Bithecocamara* Kozłowski, ca. X80; autothecal stolon, a (st).

ponding bifurcation of the stolothecal tubes where present) no details of budding are known; it was probably irregular, and the autothecae at least possessed long autothecal stolons.

SYSTEMATIC DESCRIPTIONS

Family BITHECOCAMARIDAE Bulman, nov.

With all 3 types of thecae; autothecae with well-developed collum. *L.Ord.*

Bithecocamara Kozłowski, 1949 [**B. gladiator*].
With all 3 types of thecae, and well-developed

collum on autothecae. *L.Ord.*(*Tremadoc.*), Pol.—
—FIG. 26. *B. sp.*; reconstr., ca. X80 (72n).

Family CYSTICAMARIDAE Bulman, nov.

Bithecae and stolothecae absent, stolons being embedded in extracameral tissue. *L.Ord.*

Cysticamara Kozłowski, 1949 [**C. accollis*]. *L.Ord.*
(*Tremadoc.*), Pol.

Flexicollicamara Kozłowski, 1949 [**F. bryozoaeformis*]. *L.Ord.*(*Tremadoc.*), Pol.

Graptocamara Kozłowski, 1949 [**G. hyperlinguata*]. *L.Ord.*(*Tremadoc.*), Pol.

Tubicamara Kozłowski, 1949 [**T. coriacea*]. *L.Ord.*
(*Tremadoc.*), Pol.

STOLONOIDEA

Order STOLONOIDEA Kozłowski, 1938

[Introduced by Kozłowski in 1938 without diagnosis but descriptive notes in text; defined by BULMAN (8) in 1938 but first adequately described by Kozłowski (32) in 1949]

Sessile or encrusting Graptolithina composed essentially of stolothecae and ?autothecae; stolothecae containing an exaggerated development of stolons dividing at irregular intervals and quite irregular in form. *L.Ord.*(*Tremadoc.*).

MORPHOLOGY

This order is represented by extremely fragmentary remains and only an imperfect

account of morphology can be given. It is, however, clearly distinguished from all other orders of Graptolithina by extraordinary development of the stolons themselves. These divide quite irregularly, in some forming whole interlacing groups (Fig. 27,1) and in others giving off single branches. Their course is erratic, vermiform, and they vary greatly in diameter from 50 to 350 microns. They have thick walls and the central lumen usually is filled with secondary deposit. The stolons are included in stolothecal tubes, either singly or in sheaves or groups, but these appear to have been extremely fragile and are preserved

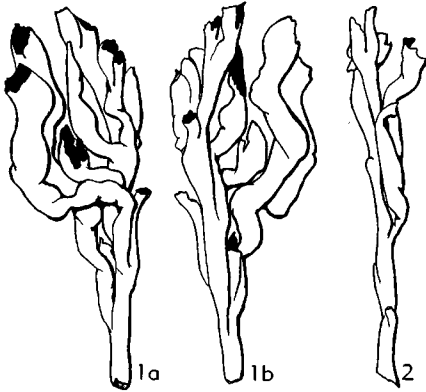

FIG. 27. Stolonodendridae (p. V43).

only rarely. The stolothecal tubes possess a normal though somewhat irregular fusellar structure, except on the lower surface of the encrusting forms where the thecal wall is structureless (as in Camarotoidea).

The stolons appear to leave the stolothecae by pores produced by resorption, and

on leaving the parent stolotheca give rise to new stolothecae or to what appear to be autothecae. Unlike other Graptolithina, where a sudden passage occurs from stolon to base of theca, the stolon here steadily increases in diameter until at a certain point the structureless chitin of the stolon gives place to the fusellar structure of the theca proper. Autothecae are no more commonly preserved than stolothecae but were evidently tubular, straight or more commonly curved, with fusellar walls, opening on the surface of the colony with apertures devoid of any apertural processes.

SYSTEMATIC DESCRIPTIONS

Family STOLONODENDRIDAE Bulman, nov.

Characters of the order. *L.Ord.*(*Tremadoc.*)

Stolonodendrum KOZŁOWSKI, 1949 [**S. uniramiosum*]. Only genus. *L.Ord.*(*Tremadoc.*), Pol.—
FIG. 27, 1, 2. *S. sp.*; fragments of stolons, $\times 20$ (32).

GRAPTOLOIDEA

Order GRAPTOLOIDEA Lapworth, 1875

Planktonic or epiplanktonic Graptolithina, sicula pendent from nema (virgula); stipes pendent to scandent in relation to this, uniserial or biserial (very rarely quadriserial); rhabdosome generally of few stipes, comprising only one type of theca (autotheca). *L.Ord.-U.Sil.*

MORPHOLOGY

GENERAL FEATURES

The Graptoloidea may best be regarded as simplified Dendroidea, to which order they are closely related through the family Anisograptidae. Such simplification involves the loss of bithecae and loss of a chitinized stolon; accordingly, there is no sign in a graptoloid branch of the triad budding on the "Wiman rule" which distinguishes the Dendroidea. It is reasonable to infer the persistence of some unchitinized form of stolon (*gymnocaulus*), and the common canal (*protheca*) of the Graptoloidea is morphologically equivalent to the dendroid stolo-

theca. The transformation probably was gradual and placing of the Anisograptidae is arbitrary; as defined (p. V32), this family includes genera known to possess the typical dendroid branch structure, leaving the graptoloid branch to be defined as composed of autothecae and a common canal only. Following the loss of bithecae, the stipe shows a very general tendency to increase in breadth to a distal maximum.

The sicula gives rise laterally to a single initial bud from which ultimately the entire rhabdosome develops, and the apex of the sicula is prolonged as a slender thread known as the *nema* (or *virgula* in scandent forms) by the distal end of which the rhabdosome in general was attached. The relation between direction of growth of the branches of the rhabdosome and the nema affords an important basis of subdivision among the Graptoloidea, and varies (Fig. 28) from pendent, through horizontal and reclined, to scandent, a general tendency in history of the group being toward attainment of a scandent direction of growth. There is likewise a general tendency toward

reduction in the number of branches, the earliest genera being for the most part multiramous forms, whereas the youngest genera are composed of but 1 or 2 scandent stipes (Diplograptidae, Monograptidae). In these scandent forms it was not at first recognized that the virgula is in fact identical with the nema of pendent forms. FRECH's suggested orders, *Axonolipa* and *Axonophora*, based essentially on absence or presence of an "axis," really reflect the degree of scandency attained by the rhabdosome, following the reduction in stipe number to 2 or 1. No hard and fast line can be drawn between them, however, and the dicellograptids and dicranograptids were placed by FRECH in his *Axonophora* while RUEDEMANN, adopting the orders with slight modification, includes them in the *Axonolipa*.

Loss of bithecae and particularly reduction in number of stipes results in a striking reduction in the total number of thecae in a rhabdosome. From as many as 20,000 to 30,000 in a large *Dictyonema flabelliforme*, the total falls to 2,000 or 3,000 in some *Clonograptus* species, and perhaps in a large multiramous dichograptid; averages of 100 to 200 occur in most leptograptids, dicellograptids, and diplograptids; 50 to 100 in a

typical *Monograptus*; and no more than 10 to 20 in the late Ludlow monograptids.

PERIDERM

As in the Dendroidea, the periderm consists of fusellar and cortical layers, but as a rule, the development of cortical tissue is not great and growth lines of the fusellar layer usually are not obscured from this cause; where visible, they are of considerable value in tracing the mode of origin and direction of growth of different parts of the rhabdosome. Whether the web and disc structures of many dichograptids, which rather commonly exhibit "growth lines," are fusellar or cortical is unknown. The lacinia and parts of the clathria (Fig. 66) are very possibly cortical in nature.

SICULA

The sicula of the Graptoloidea is in general more conspicuous than that of the typical dendroids. Its significance was first recognized (LAPWORTH, 1875) and its morphology worked out (WIMAN, 1893; KRAFT, 1926; and others) in the Graptoloidea, and its role in the Dendroidea only lately has been fully appreciated (p. V28).

The walls of the prosicula are strength-

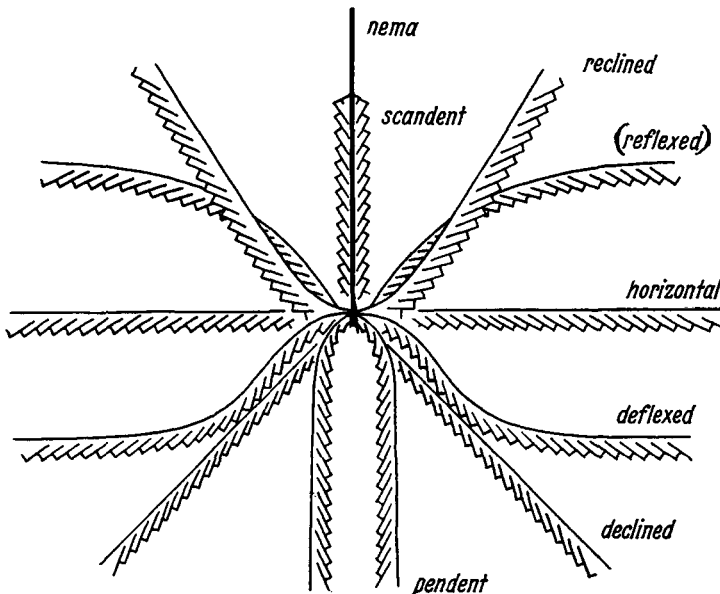

FIG. 28. Diagram illustrating relations of graptolite stipes to nema and terminology applied (8).

ened not only by the spiral thread (*Schraubelinie* of KRAFT) but also by longitudinal rods of fibers (*längsverstärkungsleisten*). Three or 4 of these merge into the base of the nema, where it grows out as a hollow tube from the apex of the prosicula, and clearly serve as an anchorage for this; the remainder seem to grow from the apertural margin of the prosicula, where they are thickest, thinning and disappearing when traced toward the apex.

The metasicula is sharply distinguished from the prosicula by its close-set regular growth lines, meeting in a zigzag suture down the two opposite sides (dorsal and ventral); on one side (the virgellar or ventral side) is embedded the virgella (usually a conspicuous spine), while on the other, symmetrically placed apertural spines (2 or, rarely, 1) may arise when growth is complete (Fig. 36).

In size, the sicula varies between wide limits; usually 1.5 to 2.5 mm. in length, it attains 5 or 6 mm. in some monograptids (*Monograptus gregarius*, *M. acinaces*) and *Orthograptus vesiculosus*, and it may be a centimeter or more in *Corynoides*. In shape, however, the sicula varies scarcely at all and apart from slight differences in the length-breadth ratio, or a gentle curvature, apertural spines and processes are the only modifications recorded.

More or less regularly spaced internal rings of secondary thickening have been described in the siculae (and very rarely on proximal thecae) of certain *Monograptus* species (Fig. 46,2). The significance of these is uncertain, but it can be stated that they do not correspond to periods of arrested growth, and that seemingly they are composed of ridges of cortical tissue.

In the Archiretiolitinae, the sicula usually is fully chitinized, but in the true retiolitids it is either unchitinized or represented only by the prosicular portion (see section on "Development").

THECAE

GENERAL RELATIONS

The form of the thecae, particularly in the apertural region, varies greatly and in fact constitutes one of the most valuable bases for the recognition of species and even genera (e.g. *Rastrites*, *Climacograptus*). The

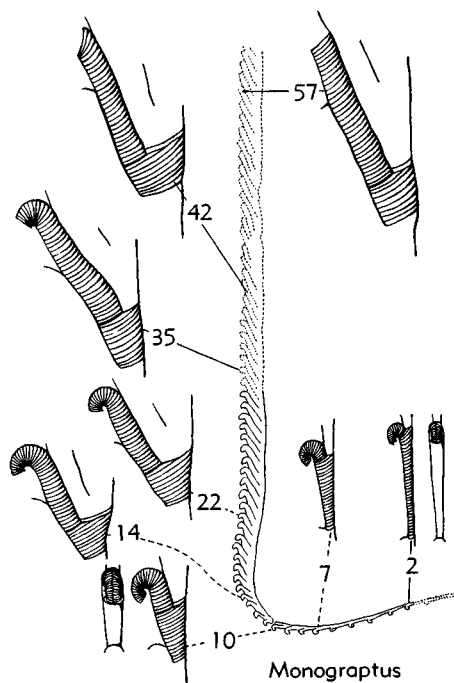

FIG. 29. Thecal changes along rhabdosome of *Monograptus argenteus* (NICHOLSON); outline of rhabdosome, $\times 2$, enlarged thecae, $\times 10$ (72).

subject of thecal elaboration was first systematically discussed by ELLES (1922), who emphasized that form of the thecae is not necessarily constant throughout the rhabdosome. According to ELLES, the new thecal type is introduced at the proximal end in progressive series (especially noticeable among monograptids) spreading gradually along the length of the rhabdosome (Fig. 29). Some evidence, however, indicates that thecal changes affect the distal part of the rhabdosome alone, and in *Cyrtograptus* the more conspicuous changes commonly appear to be in the distal thecae.

Outwardly, the simplest form of graptoloid theca is a straight almost cylindrical tube, partly overlapped by that which precedes it and partly overlapping that which follows it. In the past much confusion has existed in the precise use of such terms as "theca," "common canal," "interthecal septum," etc., but largely through the work of WALKER (1953), URBANEK (1954), and others it now seems possible to define the

parts with some precision. So far as concerns the periderm, each theca develops from the preceding theca and there is usually a slight but definite break or "unconformity" between the growth lines of one theca and the next. Each theca can be divided into 2 parts, a **protheca** (BULMAN) corresponding to the stolotheca of the dendroids, and a **metatheca** (URBANEK) corresponding to the autotheca of the dendroids¹ (Fig. 30). The sum of the prothecae of a stipe constitutes the common canal of earlier authors and corresponds to the chain of stolothecae along the dorsal side of a dendroid branch.

With minor exceptions, such as the apertural processes of certain monograptid species, a theca remains bilaterally symmetrical in the plane of the stipe, whatever modifications in form it may undergo.

INTERTHECAL SEPTA

The **interthecal septum** seems in general to comprise parts of both thecae which it serves to separate; the initial (proximal) portion is composed of growth bands which are continuous with the earlier theca, and

the distal portion is formed by the later theca (Figs. 30,2; 42,3; 46,4). THORSTEINSON remarks, however, that in some cyrtograptids the interthecal septum is formed entirely by the ventral wall of the succeeding theca.

PRINCIPAL TYPES

Simple straight thecae (Fig. 30,1,2) characterize the uniserial stipes of the vast majority of dichograptids, many simpler monograptids, and the biserial stipes of certain diplograptids; accordingly, this has been appropriately termed the **dichograptid type**. Exceptionally, however, even dichograptids may show more advanced types (*Didymograptus leptograptoides* MONSEN) or even quite highly elaborated thecae (*D. callothea* BULMAN).

The first widespread thecal elaboration is a gentle sigmoidal curvature of the ventral wall, accompanied by elongation and reduction in the angle of inclination, which results in the so-called **leptograptid type** (Fig. 31,1). This is foreshadowed in some dichograptids (*Didymograptus euodus*) and fully attained in a few (*D. leptograptoides*), but finds its typical development in the Leptograptidae, occurring also in some monograptids. Somewhat similar is the type seen in

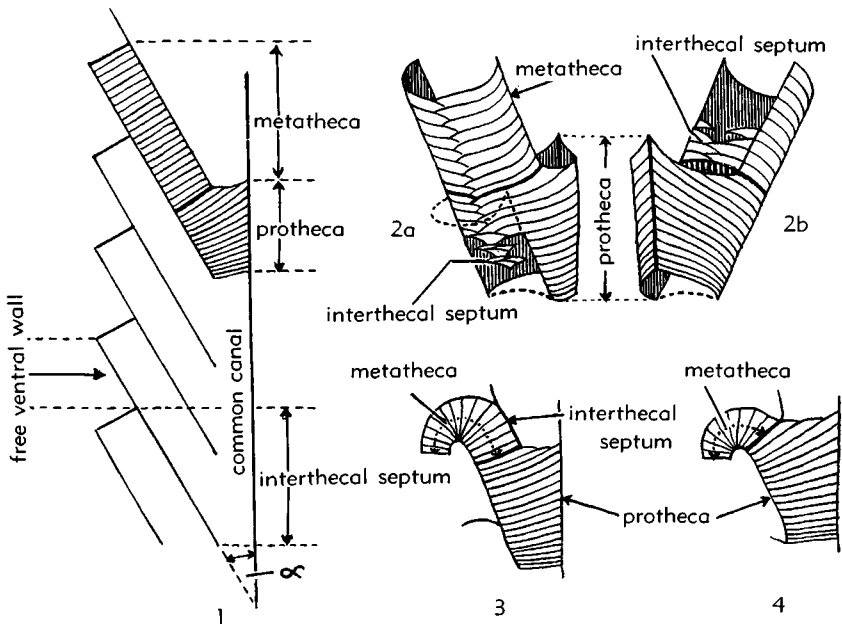

FIG. 30. Diagrams illustrating terminology of a graptolite stipe and thecae (alpha= angle of inclination).

Glyptograptus (Fig. 31,2) among biserial forms, and in early species of *Dicellograptus* (Fig. 31,3) and *Dicranograptus*. In the 2 last-named genera, it may be accompanied by slight isolation of the aperture (Fig. 31,4) and later by introversion (inturning of the aperture), through the development of an exaggerated ventral lip which more than counteracts the isolation of the dorsal rim and almost closes the aperture (Fig. 31,5). A more pronounced expression of this sigmoidal curvature results in the sharply angular geniculation of the **climacograptid** type (Figs. 31,6,7); many diplograptids,

and some species of *Monograptus* show this, and it too may be accompanied by a sharp introversion of the apertural margin, as in *Amplexograptus* cf. *coelatus* (Fig. 31,8).

Thecal modifications are most conspicuous in the Monograptidae; dichograptid, leptograptid, and climacograptid types occur here, but the more extreme modifications all involve some degree of apertural "isolation." In these Silurian forms, however, the theca, as it becomes free distally, twists outward with excessive development of the dorsal lip (retroversion), in contrast to the introversion of the more extreme dicellograptids

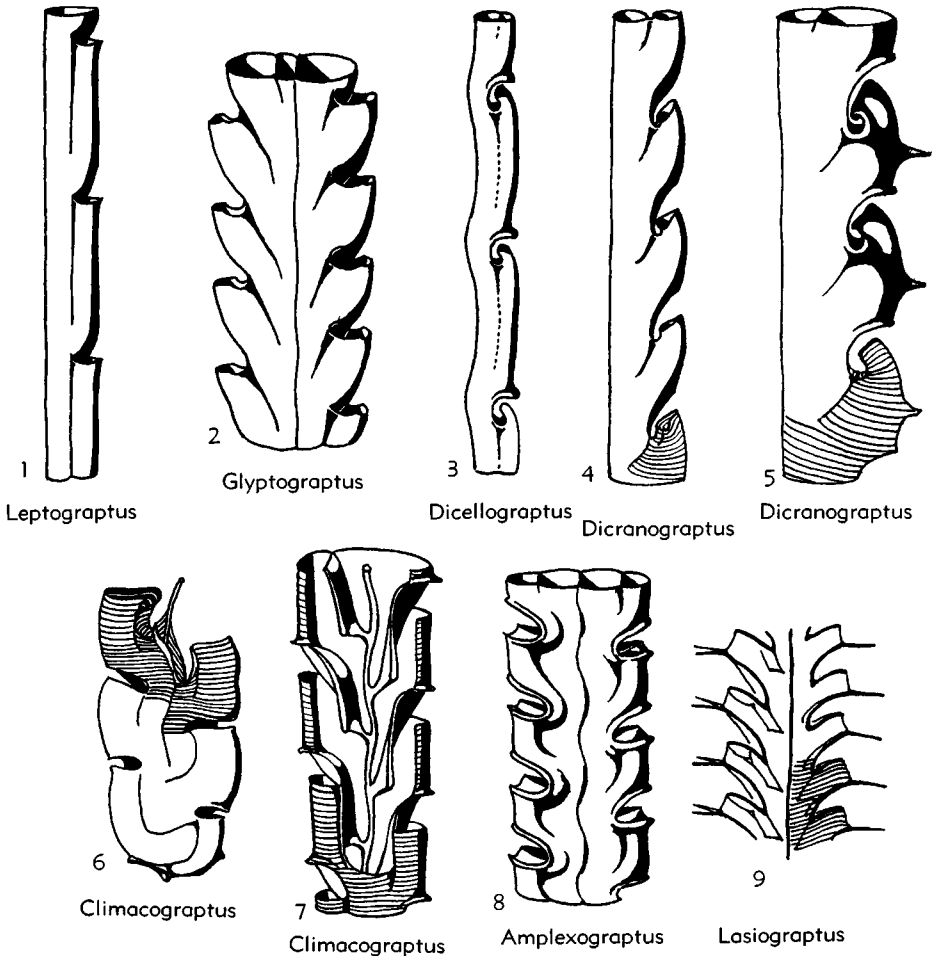

FIG. 31. Variations in graptolite thecae, mostly somewhat diagrammatic (8). 1, *Leptograptus*, $\times 15$. 2, *Glyptograptus*, $\times 15$. 3, *Dicellograptus geniculatus*, $\times 19$. 4, *Dicranograptus pringlei*, $\times 11$. 5, *Dicranograptus nicholsoni*, $\times 11$. 6, *Climacograptus scharenbergi*, $\times 22$. 7, *Climacograptus typicalis*, $\times 19$. 8, *Amplexograptus* cf. *coelatus*, $\times 13$. 9, *Lasiograptus harknessi*, $\times 10$.

and dicranograptids of the Ordovician. Accompanying this isolation is a reduction or loss of the interthecal septum and an increase in the prothecal ratio (defined as ratio of protheca to combined protheca and metatheca) (Fig. 30,3,4); thecal overlap can only be recognized in a restricted sense and ceases to have any precise descriptive or systematic value. ELLES (1922) recognized 3 main lines of this monograptid development (hooked, lobate, isolate), and the term "triangulate" has also been applied, particularly to early stages in the isolate

development and to certain hooked forms in which the interthecal septum is lost.

In the hooked type, the isolate distal portion of each theca grows back upon itself in the form of an open hook, familiar in the widely distributed *Monograptus priodon* (Fig. 32,1). Typically no transverse widening of an apertural region occurs. The thecae may overlap sufficiently to produce an appreciable interthecal septum, but in others provisionally included here (*M. clingani*) this may be lost, giving a prothecal ratio of 100 per cent. From the former type, ELLES

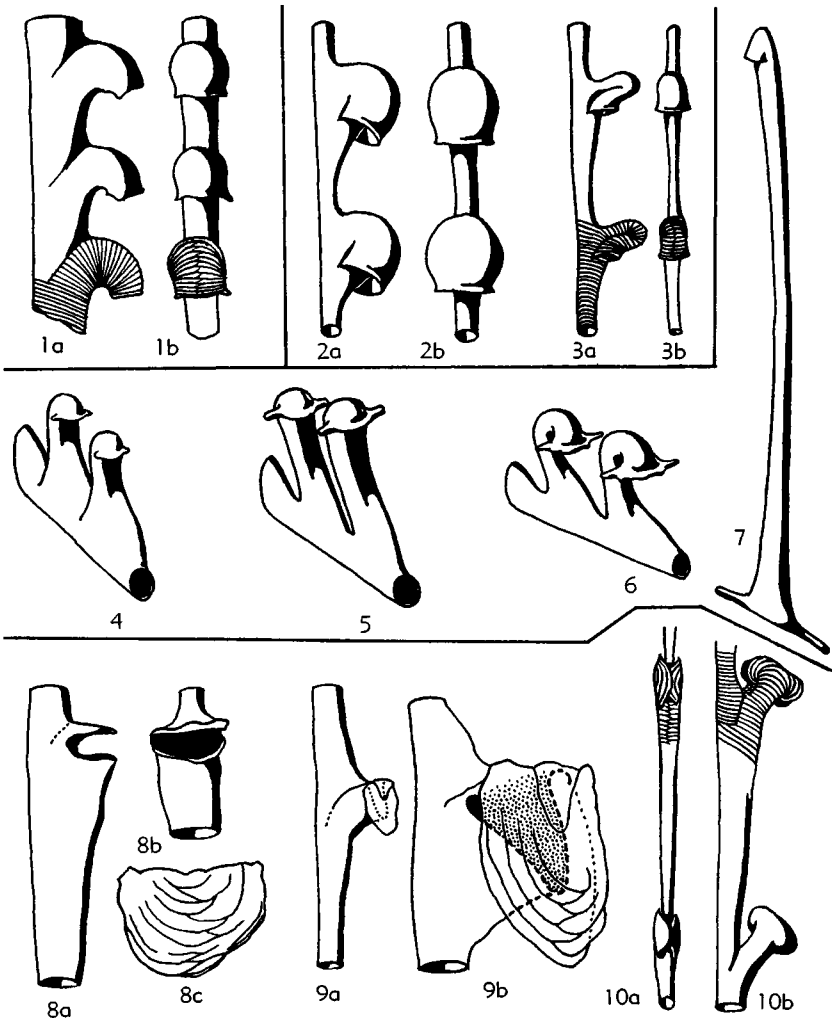

FIG. 32. Variations in monograptid thecae, somewhat diagrammatic (72). 1, *Monograptus priodon*. 2, *M. lobiferus*. 3, *M. knockensis*. 4, *M. triangulatus*. 5, *M. convolutus*. 6, *M. spiralis*. 7, *Rastrites* (8). 8, *M. sp.*; 8a,b, $\times 35$; 8c, $\times 60$ (86). 9, *M. huckei*; 9a, $\times 25$; 9b, $\times 100$ (86). 10, *M. scanicus*.

claimed that retrogressive evolution followed and the hook development, after attaining its acme in *M. priodon*, "declines through *M. flemingii* var. *compactus* to *M. colonus*, where the proximal thecae alone retain the hooked character."

The lobate type is really a very compact form of hook developed exclusively by the dorsal wall, which grows out and back over the thecal aperture like a cowl. Its highest development is seen in such species as *Monograptus lobiferus* (Fig. 32,2) and *M. becki*, where the thecal aperture is almost closed and the thecae appear in compressed material as a series of evenly spaced, rounded protuberances along the stipe. A related form is seen in *M. cf. knockensis* (Fig. 32,3), where isolation is more strongly marked and the lobe less inflated.

In the isolate type there is typically no trace of an interthecal septum, and the more extreme developments are so unlike normal Monograpti that they long ago received the separate generic name *Rastrites*. In less extreme development (*Monograptus spiralis* or *M. convolutus*, Fig. 32), the thecal segment is more or less triangular and the theca is distinctly hooked, but with an enrolled dorsal lip and transverse spinous processes; the theca in profile view appears triangular, with a "flowing" apertural spine (one or other of the transverse processes), its apparent form depending on shearing. In *Rastrites* itself (Fig. 32,7) the straight slender thecal tubes terminate in a compact lobate aperture and are sharply differentiated from an extremely tenuous common canal, from which they extend at high angles as a row of uniformly spaced parallel tubes.

In addition to these dominant types, others are beginning to become known through the work of EISENACK, MÜNCH, BULMAN, URBANEK, and others on "etched" graptolites from Silurian limestones. For the most part, these appear to consist of variously elaborated apertural shields (Fig. 32,8,9) and "lappets" developed on otherwise simple, almost dichograptid, thecae with very little overlap, e.g., *Monograptus scanicus* (Fig. 32,10). Where poorly preserved or compressed, some of these might easily be mistaken for early lobate or hooked forms, and it is possible that such structures are

of more general occurrence than has yet been recognized, especially in view of their occurrence also among the dendroids (e.g. *Dendrograptus cofeatus* KOZŁOWSKI).

MONOGRAPTID TRENDS AND THEIR SIGNIFICANCE

The lobate, hooked, and isolate types of monograptid thecae appear to represent definite trends, each affecting a considerable number of species; there may be others as yet undescribed. As these recognized trends operate over a comparatively short period of time and seem to be nonrecurrent, the species concerned may be closely related, that is, the groups might form a reliable basis of generic subdivision; but there is as yet no evidence that this is so, and on the contrary, some indication is found that they do not form genetic groups.

They are more or less contemporaneous, starting in the *cyphus* and *triangulatus* zones, and so far as is known, all affect forms which lived side by side in a common environment. They have a different rate of development, however, the isolate, lobate, and hooked series attaining dominance and then their acme in the order named. The former disappeared without trace, but some hooked forms are believed (ELLES, 1922) to show a retrogressive series in the upper Wenlock and lower Ludlow.

It has been suggested recently (THORSTEINSSON, 1955) that throughout the cytograptids the proximal thecae are invariably of a closely comparable type, and that differences appearing in the distal thecae cannot be classed exactly as retrogressive. Furthermore, there is a significant relationship between cladial and main-stipe thecae which results from an addition of the same type of theca to all growing points of the rhabdosome (p. V65). Similarly among septate biserial forms, such as *Diplograptus* (*Diplograptus*), comparable changes are being expressed independently by the 2 series of thecae.

So little detailed morphological or phylogenetic work has yet been done on these series that the significance of the changes remains obscure. WESTOLL's (in ZUCKERMAN, 1950) application of the potential hypermorph concept may apply to some "retrogressive" series, but in most a transformation of thecal form must be involved.

THECAL SPINES

Certain species of almost all graptolite genera show a development of apertural spines on some or all thecae of the rhabdosome, and every gradation is found between an angular denticle and an elongate spine. The apertural spines of some species are paired structures (e.g., *Orthograptus quadrimucronatus* or *Monograptus leintwardinensis*), and in some varieties of the *O. quadrimucronatus* group the spines of one particular thecal pair (constant for the variety) may be of exaggerated length. Mesial spines, growing from the ventral wall of a theca, are not uncommon (advanced dicellograptid and climacograptid types of theca), particularly at the proximal end of

a rhabdosome. RUEDEMANN (1947) has observed that whether apertural or mesial, spines usually are placed at the most exposed portion of the theca.

The most remarkable spinous developments occur among the lasiograptids (Fig. 65), where apertural and mesial spines are of great length and may break up distally to form an interlacing network (lacinia) outside the thecal apertures. Such structures presumably are of cortical tissue, secreted by the hypothetical external tissue of the colony rather than by the zooids themselves.

A pair of basal spines carried by the first 2 thecae is extremely common, especially among biserial graptolites, and in *Climacograptus bicornis*, where such spines are un-

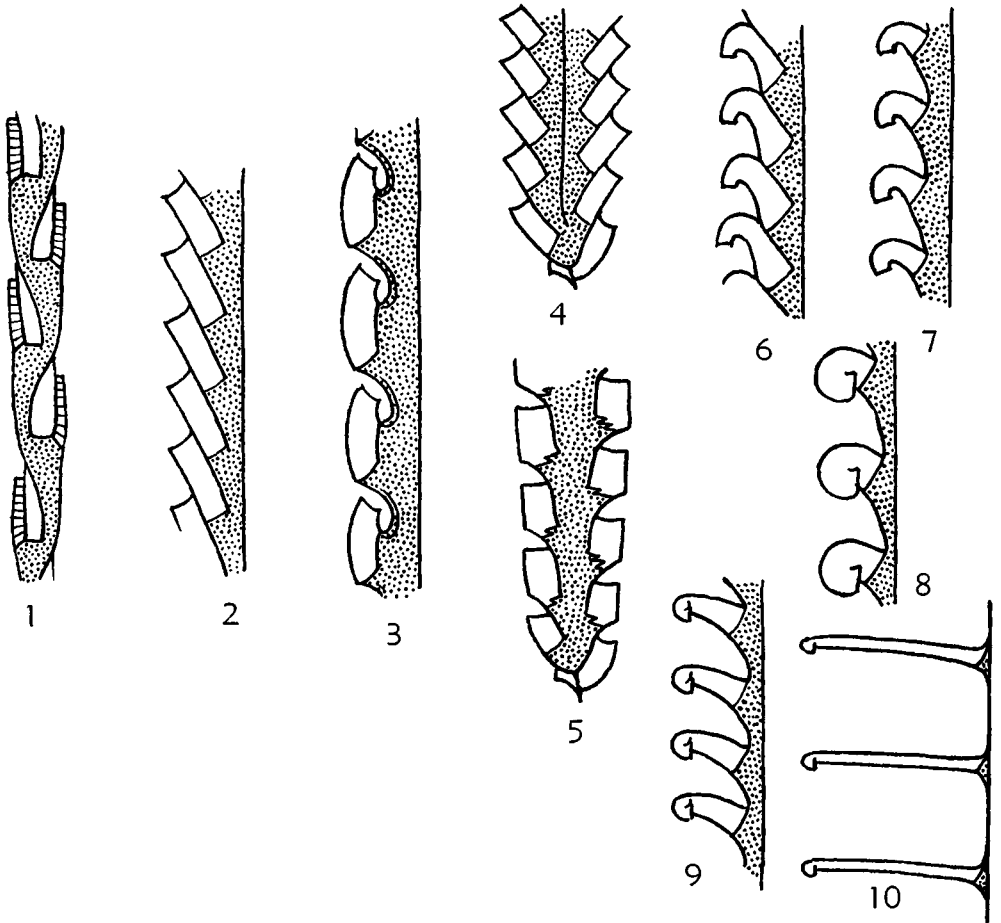

FIG. 33. Diagrams illustrating relations of thecae (white) to common canal (stippled) in various types of graptolites; dorsal view of dendroid branch (extreme left) with stolothecae stippled and bithecae shaded.

usually large, the first 2 thecae may become completely involved, their distal portions growing back along the spines. A group of basal spines may be formed by mesial or apertural spines of the first thecae together with the virgella and apertural spines of the sicula.

COMMON CANAL

As already stated (p. V45), each theca appears to "grow out" from the preceding, and in terms of zooidal relations the only possibility of a permanent terminal bud seems to be for such to project ahead of any chitinized skeleton, the whole of which must be secreted by the later developing buds. On the more probable view that each zooid has budded from the preceding, as a direct inheritance of its dendroid ancestor, the common canal of earlier writers has no real entity, since it consists only of the sum of the prothecae of a stipe. Nevertheless there is often a real need in descriptive work dealing with gross morphology for some term to denote this portion of the rhabdosome, and the use of the term in this sense may be defended (Fig. 33).

A remarkable structure called the appendix occurs in *Gothograptus* and some other members of the Plectograptinae where the common canal may extend as an open tube along the virgula beyond the thecate portion of the rhabdosome (Fig. 66,10).

NEMA OR VIRGULA

Among the Dichograptidae, with exception of *Phyllograptus*, a threadlike nema extends from the apex of the prosicula and probably served (as suggested by LAPWORTH) for fixation of the rhabdosome; examples are known where it terminates distally in a somewhat irregular disc of attachment. In the Leptograptidae and Dichellograptidae, the nema usually is so short that it is not obvious how it can have served for attachment, and *Dicranograptus* appears to have been without a nema. Among Diplograptidae, however, it is invariably present as a central tube or axis, here known as the virgula, embedded in the median septum or in aseptate forms lying freely in the cavity of the common canal and in some anchored by fusion to bases of the intertheatal septa (Fig. 34,1). Even where embedded in the

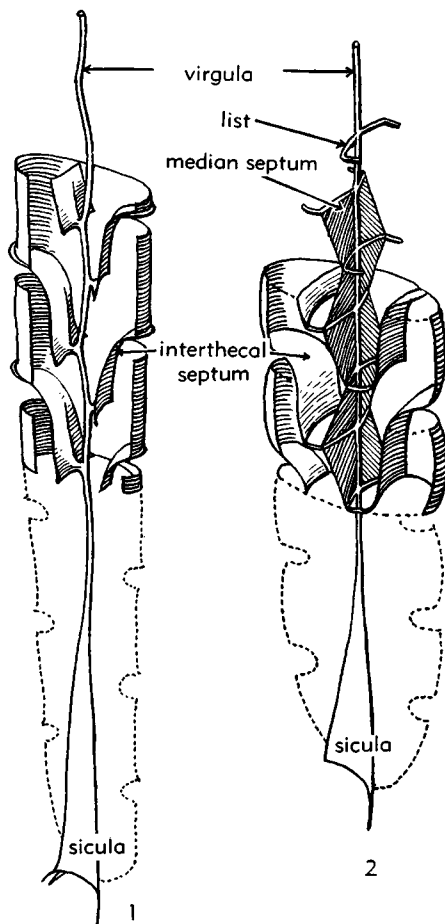

FIG. 34. Stereograms showing relations of virgula to median septum and intertheatal septa in biserial graptolites (7). 1, Aseptate, *Climacograptus typicalis*. 2, Septate, *C. scharenbergi*.

median septum, additional strengthening lists may be developed (also in the median septum) connecting the virgula with the lateral walls of the rhabdosome, as in *Climacograptus scharenbergi* (Fig. 34,2). In monograptids, the virgula is embedded in the dorsal wall of the stipe. RUEDEMANN has figured a *Dicranograptus* with what purports to be a virgula extending from each uniserial branch; but this must be erroneous, for the nema (or virgula) cannot split or divide distally in this way. The relations in such "pseudobranching" monograptid genera as *Diversograptus* and *Cyrtograptus* are described elsewhere (p. V66).

The doubtful relations of the virgula in retiolitids have been resolved largely by the work of EISENACK, and it is now known that the "straight axis" in the lateral wall of *Retiolites* is the true virgula. In other retiolitids it may be free and axial in position, and in others again end blindly within the rhabdosome, perhaps continued as an unchitinized thread.

Several biserial graptolites, such as *Climacograptus parvus* and *Orthograptus vesiculosus*, possess what has been interpreted as a float at the distal end of the virgula. It is doubtful whether some of these bodies were themselves vesicular, but they may well have supported some membranous float.

Stellate groups of rhabdosomes attached to some central body (synrhabdosomes) are discussed elsewhere (p. V66), but the occurrence of immature rhabdosomes in such groups, attached by very short virgulae, indicates that increase in length during growth of the rhabdosome must have been possible. It may be that during the phase of growth and development, the nema (or virgula) was traversed by a threadlike prolongation of the sicular individual; it may be surmised also that, as in the Dendroidea, there was a "skin" of soft tissue covering the outside of the skeleton and hence possibly the nema. The actual attachment to a floating weed and increase in length may have been by this soft tissue and graptolites which lack a chitinized nema may have had an entirely "soft" attachment.

BRANCHING OF RHABDOSOME

Branching in the graptolite rhabdosome may be either dichotomous or lateral; in the former, the 2 branches diverge symmetrically, whereas in the latter one branch continues the original direction of growth and the other is thrown off laterally. Lateral branching (e.g., *Trichograptus*, *Nemagraptus*, *Pleurograptus*) is less common than dichotomous; the 2 types may occur together (e.g., *Schizograptus*) and may (as in *Goniograptus*) be difficult to distinguish.

The actual process of branch division is very little known. In the Dendroidea, since a branching node consists of 2 stolothecae and an autotheca, it is due ultimately to the development of 2 autothecae in place of an autotheca and bitheca (Fig. 12). In the

Graptoloidea, since only one type of theca is present, it must be due to the development of 2 buds, or of a double bud, in place of one. The meager evidence of *Tetragraptus bigsbyi* (Fig. 39) suggests that to some extent a stipe dichotomy is a replica of the proximal end development of the same colony. Dichograptid transparencies are extremely rare, and many more details are needed before any estimate can be given of the difference between dichotomous and lateral division.

Reduction in number of branches is a general tendency in graptolite evolution and indeed is a process which is carried almost to completion within the family Dichograptidae. NICHOLSON & MARR (1895) suggested that this reduction was a development to insure a more adequate food supply to the zooids; whatever the cause may have been, symmetry and balance seem to have exerted a controlling influence throughout.

The significance to be attached to the revival of branched rhabdosomes among leptograptids of the Middle and Upper Ordovician is doubtful and their possible relations are discussed on p. V71.

Those biserial graptolites which possess a complete septum may still be regarded as essentially 2-stiped, and the stipes may (pathologically) grow quite independently of one another (Fig. 35,3). The type of division, although usually slightly asymmetrical, is presumably dichotomous.

MEDIAN SEPTUM

In its most complete development, the median septum of a biserial graptolite originates between the thecae designated as $th2^2$ and $th3^1$ (Fig. 37), the first 4 thecae having an alternating origin, and it extends throughout the length of the rhabdosome. Information concerning its structure is lacking, but possibly it is originally double (literally formed by the apposition of 2 distinct stipes). More usually, growth lines of transparencies give no indication of more than one layer, the lines running inward and distally from sides of the rhabdosome to the central virgula.

In some biserial graptolites, there is a tendency for the formation of the septum to be delayed as more and more of the proximal thecae alternate in origin. The process

culminates in a wholly aseptate rhabdosome which in one sense is the only truly biserial type. Progressive delay in the origin of the septum has been shown by WAERN (1948) to have stratigraphical value in a series of forms related to *Climacograptus scalaris*. There is little general stratigraphical significance in the tendency, however, many late (Silurian) forms having a complete septum, whereas aseptate forms, or those with a notably delayed septum, may occur well down in the Ordovician.

In other instances, again, the septum may be present at first on one side of the rhabdosome only (apparently usually the obverse), thecae on the opposite side being to all appearances alternating in origin; such a condition is referred to as a partial septum. A stage has been reached in *Cephalograptus cometa* where the partial septum is apparently reduced to a mere ridge on the periderm of the obverse side.

LOCALIZED THICKENING

Certain graptolites show a marked thickening of parts of the periderm along structural lines, accompanied by attenuation or reduction of intervening areas of the test; the "shell" or box construction of the normal rhabdosome is replaced by a structural framework (clathria) of lists (strengthening rods) carrying only the most delicate chitinous "skin" or in extreme cases none at all. This is associated commonly with a profuse development of spines (apertural, mesial and lateral), in some breaking up into a filamentous network (lacinia) beyond the limits of the rhabdosome proper. Such features are developed to a varying extent in the Diplograptidae, Cryptograptidae, and Lasiograptidae; and the recent discovery of *Dinemagraptus* shows that comparable features were developed even in the Dichograptidae.

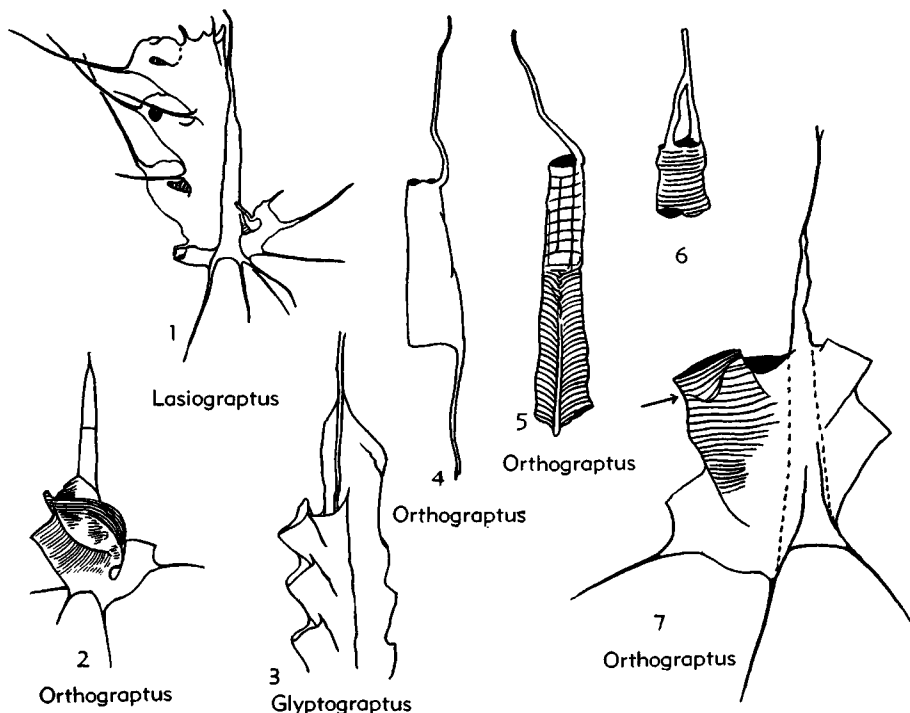

FIG. 35. Malformations and regeneration in graptolites. 1, Suppression of stipe above 2nd-formed theca (*th1*²) in biserial rhabdosome, *Lasiograptus hystrix*, $\times 18$ (7). 2, Malformation of proximal end, *Orthograptus gracilis*, $\times 13$ (7). 3, Suppression of one stipe in biserial rhabdosome at distal end, *Glyptograptus dentatus*, $\times 10$ (7). 4, Loss of prosicula, virgula attached to metasicula open at both ends, *O. gracilis*, $\times 30$ (7). 5, Damage to prosicula open-ended distally, *O. gracilis*, $\times 40$ (74). 6, Loss of prosicula, bifurcating virgula attached to metasicula, gen. indet., $\times 32$ (74). 7, Regeneration of damaged theca, *O. gracilis*, $\times 30$ (33).

A thickened selvage on the apertural margin (apertural list) occurs generally; this may be extended laterally (pleural lists) and distally (mesial list) to form a bent ring, strengthening the aperture. Such is found in some climacograptids and more particularly in amplexograptids, and may be continued into mesial and apertural spines, as in the lasiograptids. The latter usually exhibit also at least the beginnings of parietal lists along edges of the interthecal septum, and an aboral list formed by thickening of the inner edge of the septum. Completing this framework (or clathria) a longitudinal list may occur along each lateral wall of the rhabdosome, and, except where thecal overlap is almost total, a longitudinal list also appears connecting the mesial with the apertural list along the mid-ventral line of each theca.

Among the Retiolitidae, the clathria supports a delicate chitinous network, the reticula; in well-preserved specimens this seems to be covered by an exceedingly thin, possibly structureless, film, but its relations to the normal graptolite periderm are obscure.

The 3 structures, clathria, reticula and lacinia, need not be closely correlated; *Retiolites*, with perfect reticula and clathria, has no lacinia; in *Nymphograptus* and most *Lasiograptus*, the clathria is associated with a well-developed lacinia; and in *Plegmatograptus nebula* the clathria is barely developed, the reticula being distinct but irregular and the lacinia well developed.

MUSCLE SCARS

The occurrence of muscle scars in specimens of *Climacograptus typicalis* and *Orthograptus quadrimucronatus* has been claimed by ULRICH & RUEDEMANN (1931), who used this as an argument in favor of polyzoan affinities, and later by HABERFELNER in *Monograptus* (1933). The published figures are not convincing, and we agree with KOZŁOWSKI in the view that the presence of muscle impressions in graptolites is by no means established.

REGENERATION

Graptolites possessed considerable powers of regeneration of damaged skeletal tissue, and examples are to be found in any large collection of material dissolved from

the matrix (KRAFT, 1926; BULMAN, 1932; EISENACK, 1940; KOZŁOWSKI, 1949). Damage to the margin of a terminal or growing theca is repaired, without resorption, by the deposition of a fusellar skeleton with characteristic growth lines unconformable to the broken edge (Fig. 35,7); damage to, or perforation of, an already formed theca is repaired by a sheet of structureless chitin laid down on the inside of the injury.

The prosicula seems to have been rather susceptible to injury in early growth stages and the nema may be found attached to the open proximal end of the metasicula (Fig. 35,4,5). The commoner condition of a "bifurcating" nema attached by both branches to the metasicula is possibly due to regeneration (Fig. 35,6), but a comparable state appears to be normal for *Cryptograptus tricornis*, where, in addition, a membranous prosicula wall may be preserved.

DEVELOPMENT

GENERAL DISCUSSION

Development commences with the secretion of the prosicula, of which 3 stages have been recorded (KRAFT, 1926). The earliest of these (Fig. 36,1) consists of a delicate bottle-shaped object, usually 400 to 500 microns in length, open at the base and closed at the neck or nema prosiculae. It is faintly marked with a spiral thread (*Schraubelinie*) which may be coiled indifferently right- or left-handedly; this spiral thread may be strengthening, or perhaps (according to KRAFT) marks the line of fusion of a continuous spiral growth band. In the second stage (Fig. 36,2), a group of 3 or 4 longitudinal strengthening fibers is laid down from the nema prosiculae to the aperture of the prosicula. Finally (Fig. 36,3), secondary longitudinal fibers are secreted between the primaries, extending one-half to two-thirds the way from the aperture to the nema prosiculae and the growth of the prosicula then is complete.

An entirely new structure, the metasicula, now begins to appear (Fig. 36,4,5), which contrasts sharply with the prosicula in its mode of growth, being composed of the usual graptolite alternating growth bands with typical zigzag suture along opposite (dorsal and ventral) sides. These growth bands tend to extend forward along the

ventral side (Fig. 36,4), resulting in a rounded projection and later a short spine, which is finally reinforced to form the virgella spine. In nearly all dichograptids, a true virgella is absent and is represented only by a blunt or rounded ventral process. KOZŁOWSKI (1949) has suggested that the actual spine formation is deferred progressively in stratigraphically younger forms; BARRASS (1954) has claimed that the late formation in *Climacograptus* contrasts with an early formation in *Diplograptus* (*s.l.*). When growth of the metasicula is complete, apertural spines, almost invariably paired, may develop on the dorsal side opposite the virgella (Fig. 36,6).

The pore through which the initial bud or stolon passes to the exterior generally

appears when growth of the metasicula is nearly complete, and may arise in either of 2 ways. Most commonly it is produced by resorption, as is clearly demonstrated by its relation to the growth lines. In geologically early forms, such as many dichograptids and all known dendroids (Fig. 13), this is situated in the prosicula, but more usually it lies in the metasicula (Fig. 36,7) and a general tendency seems to be well established for the pore to arise progressively lower down the metasicula in later genera and species, until it comes to lie quite close to the aperture. The second method of origin is exemplified in *Monograptus*, where the pore (low down on the metasicula) is contemporary with the adjacent sicula tissue, and instead of being formed by resorption,

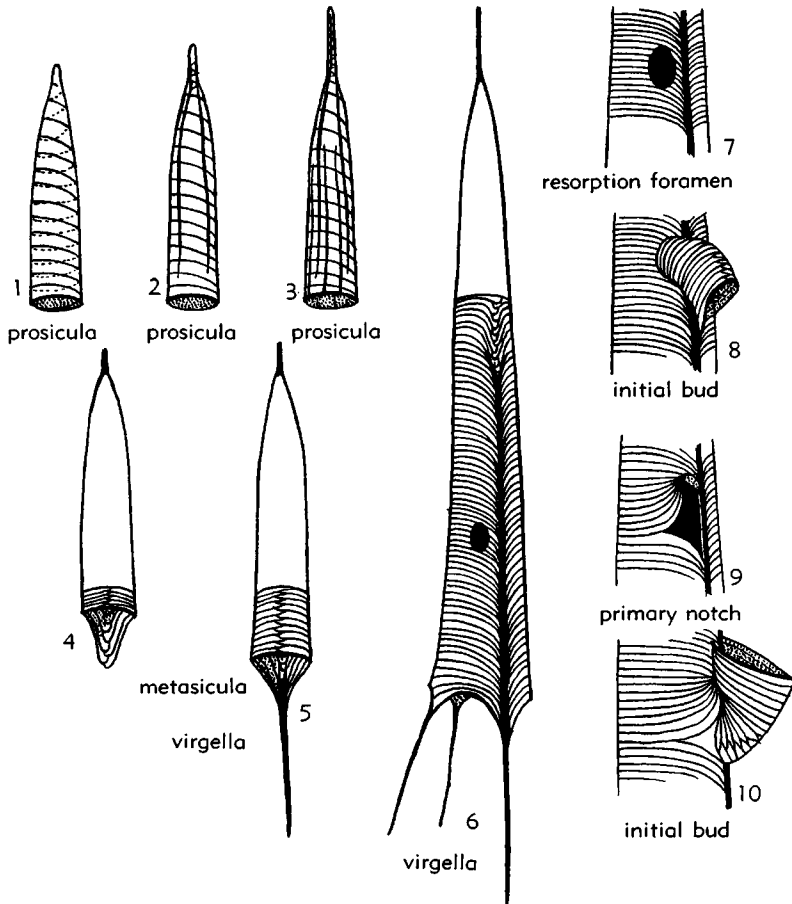

FIG. 36. Development of sicula and initial bud. 1-3, Prosicula. 4, 5, Beginning of metasicula and formation of virgella. 6, Completed sicula with apertural spines, virgella and resorption foramen, 7, 8, Resorption foramen and initial bud. 9, 10, Primary notch and initial bud.

is intercalated in modified metascicular growth bands (Fig. 36,9). Its position is normally ventral, close to the virgella, but in *Didymograptus formosus* the dorsal placement of the pore seems to be a specific feature, and there may be other exceptions.

From the pore, formed in either of these ways, the initial bud grows out and (except in *Dimorphograptus* and monograptids) down the side of the sicula. As in the dendroid stolotheca, there is no true inner wall, and the bud is a split tube fused at its edges

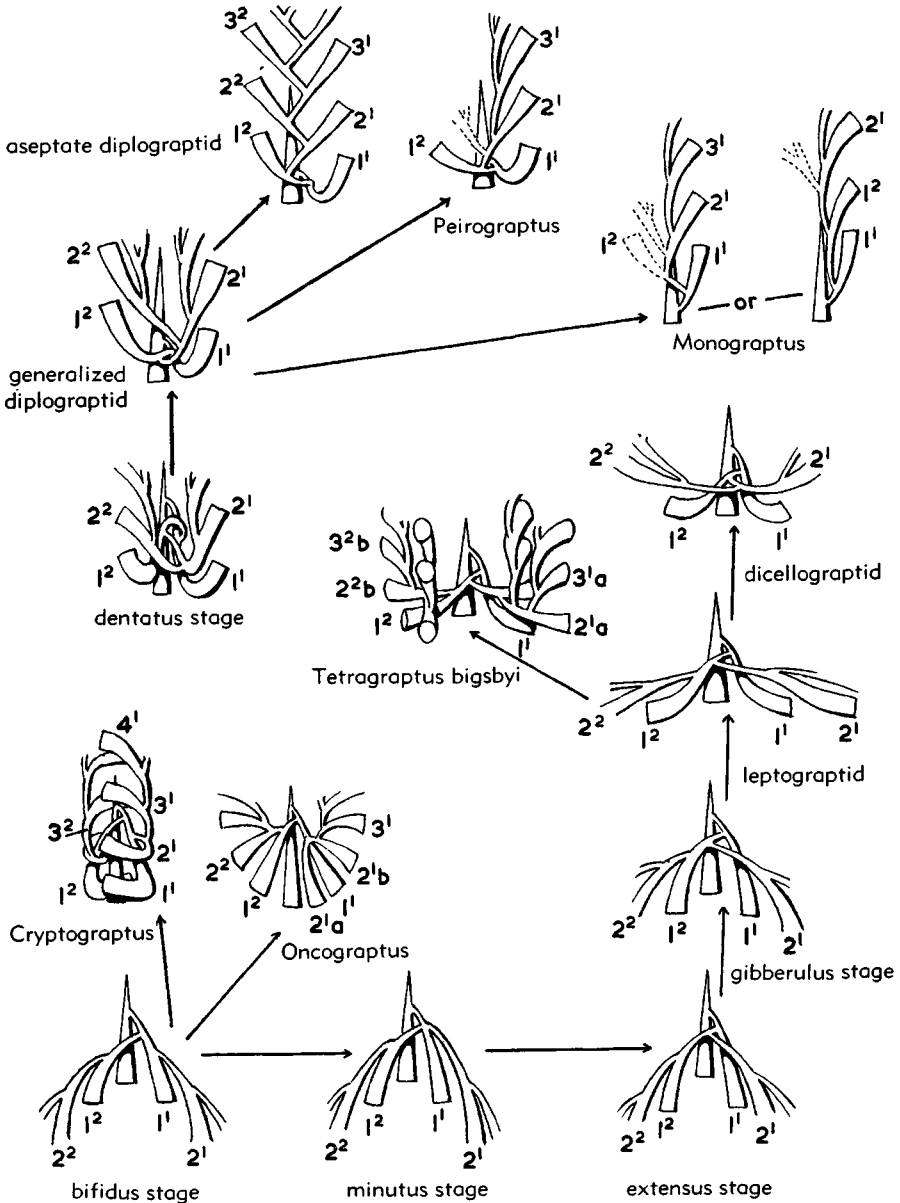

FIG. 37. Thecal diagrams illustrating progressive trends in development of the proximal end. Thecae are numbered according to convention in manner indicating their order of budding in different series, as $th1'$ (first-formed theca developed from sicula), $th1^2$ (next-formed theca, budded from $th1'$), $th2'$ (3rd-formed theca, budded from $th1'$ or $th1^2$), and so on.

to the sicula (Fig. 36,8,10). Growth bands may extend uninterruptedly from side to side or may alternate to produce a median zigzag suture. All the varying types of graptolite rhabdosomes are derived from this single initial bud by different methods of branching.

In the development of a bilateral or biserial rhabdosome, 2 buds must be borne by one zooid, and this zooid may be that occupying the first formed theca ($th1^1$) developed from the sicula, but there seems to be a general tendency to delay the initial bifurcation to the 2nd-formed theca ($th1^2$), 3rd-formed theca ($th2^2$), or even further (Fig. 37). Such delay is accompanied by an alternating disposition of the earliest thecae of the rhabdosome. The proximal parts (prothecae) of such initial thecae as cross

the mid-line on the reverse side to open on the side opposite that of their origin are referred to as **crossing canals**.

Recognition of the major types of development is due to ELLES (1922); they have been further elaborated, with recognition of stages, and constitute a continuous morphological series. The accompanying figures render unnecessary any written description of details of the processes.

DICHOGRAPTID TYPE

In the dichograptid type (Fig. 38), there is but one crossing canal produced by the 2nd-formed theca ($th1^2$), and the proximal thecae have a more or less pendent direction of growth. Steps in development are distinguished as the *bifidus* stage, and *minus* stage (Figs. 37,38).

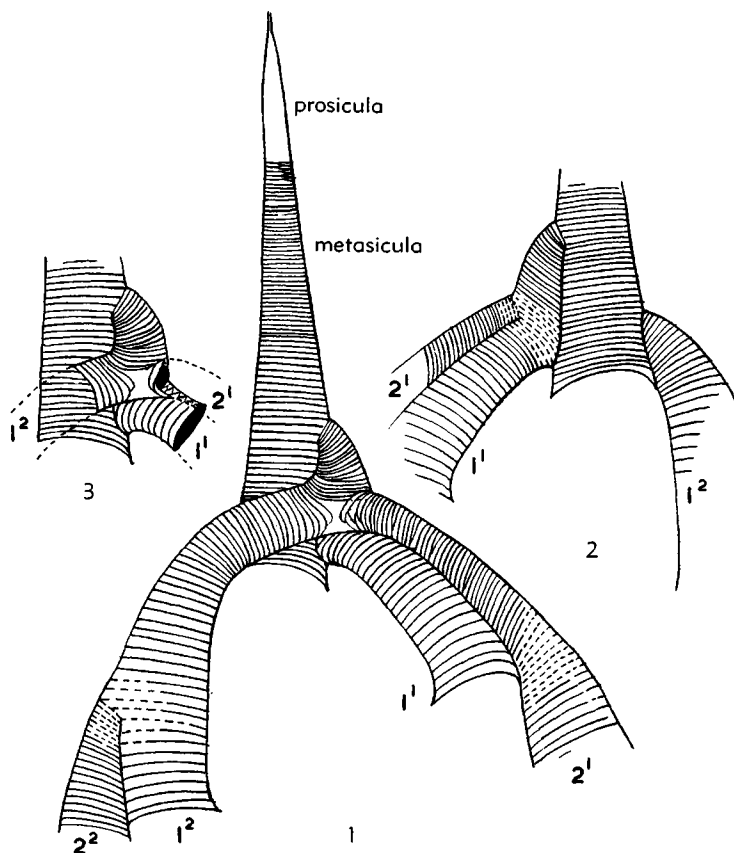

FIG. 38. Dichograptid type of development, *minus* stage (illustrated by *Didymograptus minus*). 1, Reverse aspect with single crossing canal. 2, Obverse aspect, $\times 40$ (27). 3, Hypothetical growth stage. (Growth lines where doubtful shown by broken lines.)

ISOGRAPTID TYPE

In the isograptid type (Fig. 39), the 3rd-formed theca ($th2^1$) has no connection with the 1st-formed theca ($th1^1$) but originates from the initial portion of the 2nd-formed theca ($th1^2$); accordingly there are 2 crossing canals ($th1^2$ from $th1^1$, and $th2^1$ from $th1^2$) (Fig. 39,3). The proximal thecae have typically a more or less pendent direction of growth. While it is theoretically possible to derive this from the preceding dichog-

graptid type, it may be noted that the latter appears confined to the pendent dichograp-tids, and the extensiform dichograp-tids, so far as known, start with a primitive isograptid type of development. Developmental steps include the *extensus* stage, *gibberulus* stage (Fig. 37), and *hirundo* stage.

LEPTOGRAPTID TYPE

Either 2 or 3 crossing canals may be present in the leptograptid type (Figs. 39, 40), for $th2^2$ may be derived by a 3rd crossing

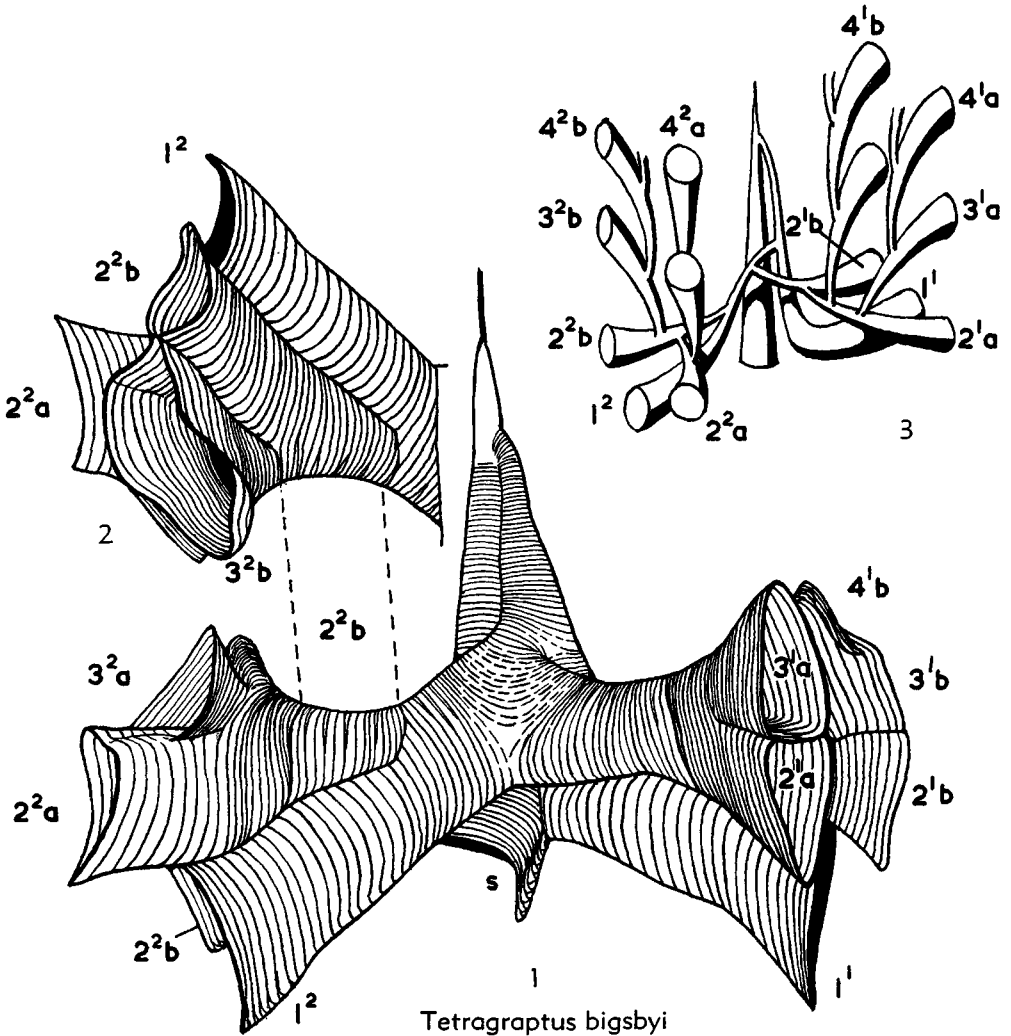

FIG. 39. Late isograptid or leptograptid type of development (illustrated by *Tetragraptus bigsbyi*, $\times 30$). 1, Reverse aspect with 2 crossing canals. 2, Obverse aspect of left side to demonstrate relations of $th2^2a$, $th2^2b$, and $th1^2$. 3, Thecal diagram illustrating relations of early thecae and mode of branching. (Growth lines where doubtful shown by broken lines.)

canal from $th2^1$; the proximal thecae have a horizontal or slightly reclined direction of growth. This is quite simply a further stage of the isograptid type of development. Developmental steps include the *flaccidus* stage (2 crossing canals) and *geniculatus* stage (3 crossing canals), as in *Dicellograptus* (Fig. 37).

DIPLOGRAPTID TYPE

The various types and stages so far enumerated, though doubtless oversimplified, form a continuous series illustrating a general principle, that of progressive delay in the separation of the two main stipes. The term diplograptid type covers a more complicated variety of developments (Fig. 41, 42, 43). The essentials of this are that at least the first 4 thecae alternate in origin, so that there are at least 3 crossing canals; that $th1^1$ and $th1^2$ have an upward direc-

tion of growth at their distal extremities; and that the resulting branches are scandent. Where a median septum is present, it originates between $th2^2$ and $th3^1$ or any subsequent thecal pair.

The origin of the diplograptids is cryptogenetic, but the earliest representative, certainly ancestral to a large part of them, is *Glyptograptus dentatus*, which exhibits several unexpected features in the proximal end. $Th1^1$ originates high up on the metasicula, and has the form of a reversed letter J; it is appreciably longer than any later theca and remains closely adpressed to the sicula until its abrupt reversal of direction. $Th1^2$ is only slightly shorter than $th1^1$ and has a sinuous shape with a considerable *upwardly* growing initial portion, whereas the initial parts of $th2^1$ and $th2^2$ are at first *downwardly* directed. Among later diplograptids, a tendency to straighten out the

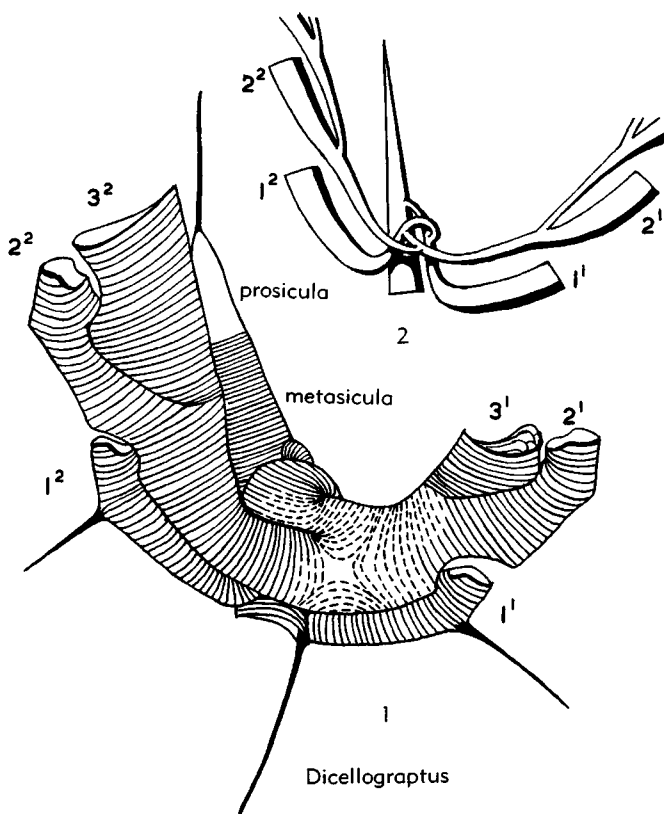

FIG. 40. Late leptograptid type of development (illustrated by *Dicellograptus* sp., $\times 40$). 1, Reverse aspect showing 3 crossing canals. 2, Thecal diagram. (Growth lines where doubtful shown by broken lines.)

course of $th1^2$ is seen, though the majority investigated retain a trace of sinuosity and in only a few forms does $th1^2$ grow in a straight reclined direction. Long after it appears to have been lost in the diplograptids,

this *dentatus* type has been found to characterize the only *Dicranograptus* yet known in detail (*D. nicholsoni*) and is used here to illustrate this development (Fig. 43). Presumably it was acquired independently, but

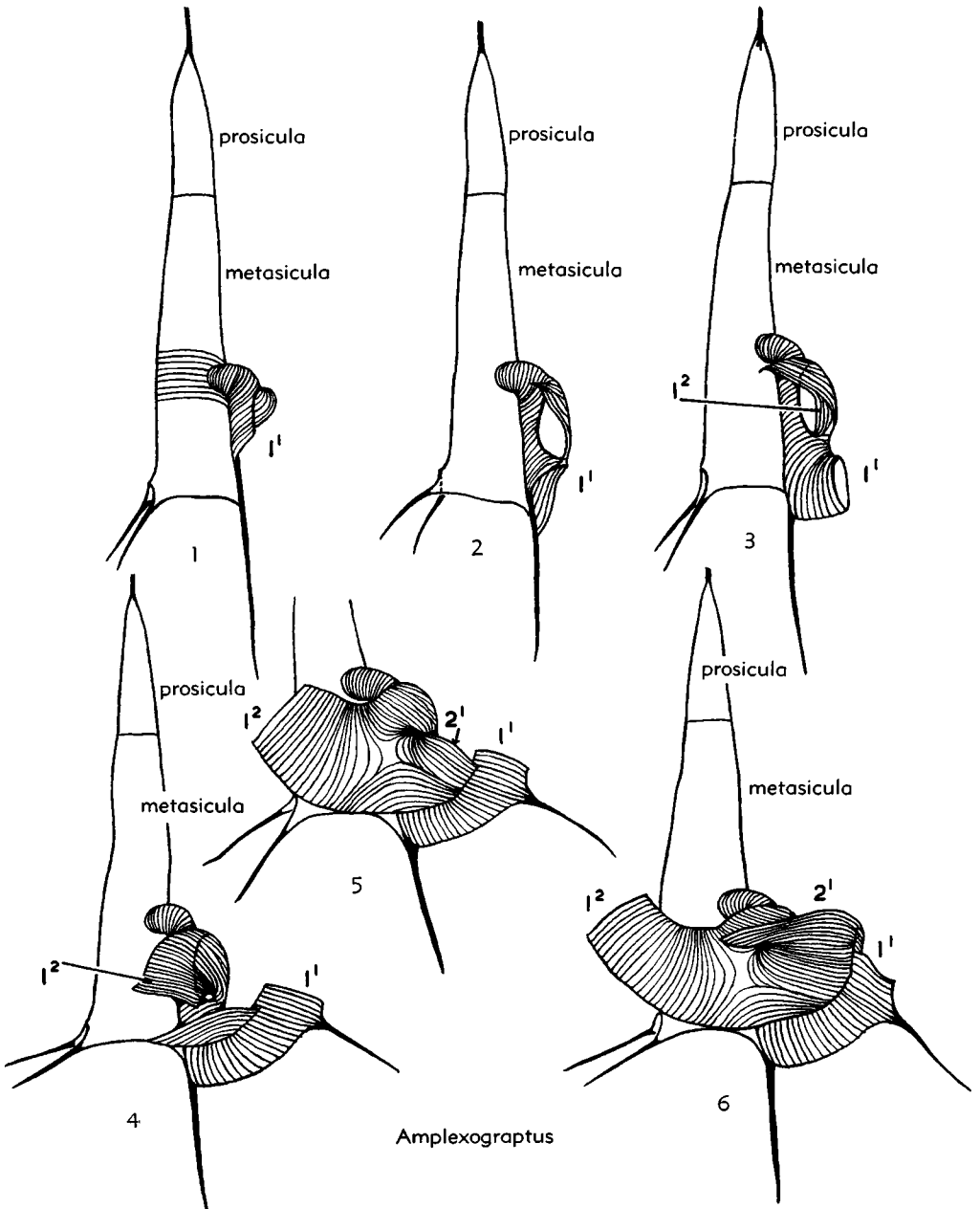

FIG. 41. Diplograptid type of development. 1-6, Series of growth stages of *Amplexograptus* cf. *maxwelli*, slightly schematic, X40 (93); 3 shows disconformity between $th1^2$ and $th1^1$; 5 shows disconformity between $th2^1$ and $th1^1$.

it makes the derivation of biserial forms from *Dicellograptus* through *Dicranograptus* somewhat difficult to envisage.

Following the straightening out of the initial parts of early thecae, the separation of the 2 linear series of thecae by a median septum may be progressively delayed as more and more of the proximal thecae alternate in origin and the number of crossing canals steadily increases (Fig. 37). There

may also be a more pronounced upward growth of $th1^1$ (including the prothecal portion); in consequence, the crossing canals pass across the virgula rather than the sicula, which latter tends to be far more completely exposed (*Cephalograptus*, Fig. 63,7).

OTHER BISERIAL TYPES

Although biserial, *Cryptograptus* exhibits a type of development which is quite dis-

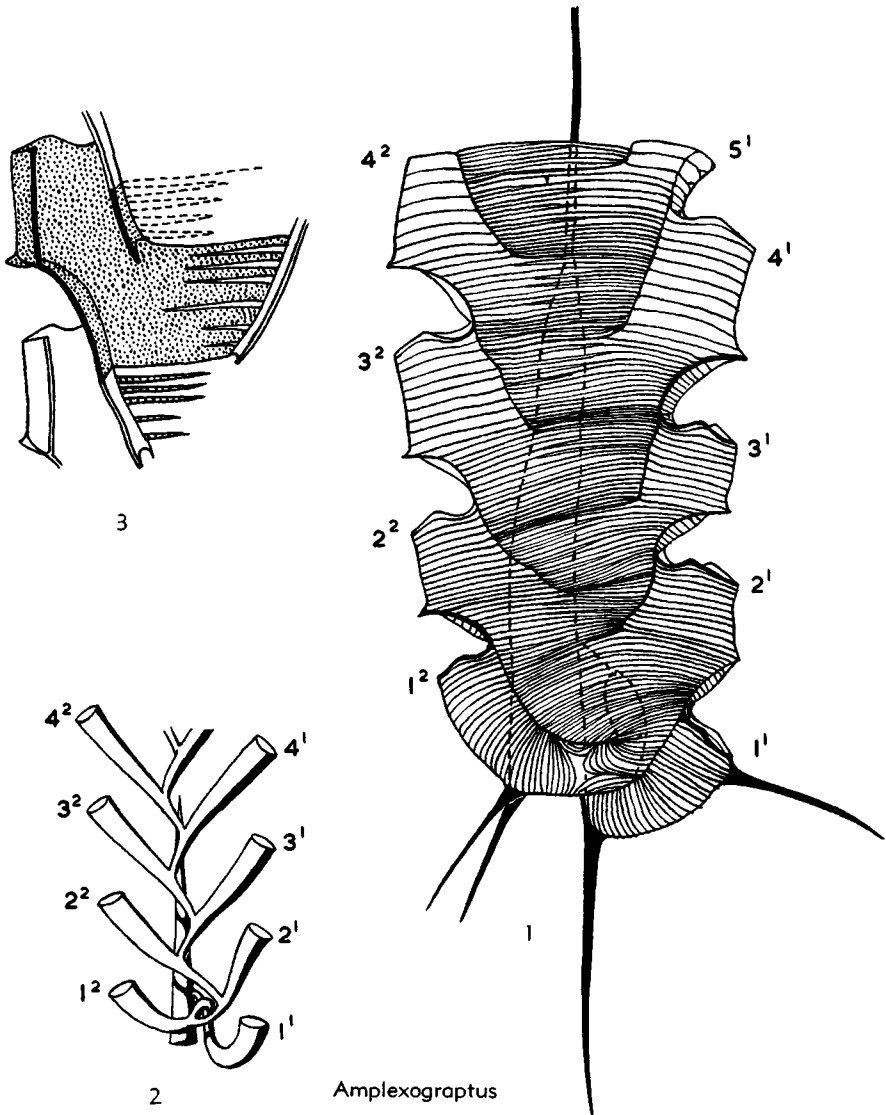

Amplexograptus

FIG. 42. Diplograptid type of development illustrated by *Amplexograptus cf. maxwelli*, $\times 40$ (93). 1, Proximal end of rhabdosome. 2, Thecal diagram. 3, Diagram showing growth relations of adjacent thecae and formation of interthecal septum.

tinct from the diplograptid, in some respects recalling an early dichograptid. Only one crossing canal occurs and the initial bud takes its origin in the prosicula (Fig. 44). The structure of the rhabdosome also is different, the scandent stipes being adnate laterally instead of dorsally. Precise details are lacking, but *Glossograptus* appears to be closely similar in development, as it is in rhabdosomal structure.

Oncograptus, *Cardiograptus*, and *Skia-graptus* likewise are biserial forms with dichograptid affinities, but few details are available.

The development of the retiolitids is very imperfectly understood. One group, the Archiretiolitinae, probably is quite distinct in origin from the others, and appears to develop on lines generally similar to the diplograptids. The sicula is fully chitinized, but it is difficult to trace the relations of later thecae in detail owing to the reduction of the periderm (Fig. 66,1,2). The Retiolitinae and Plectograptinae present a different appearance. The sicula is unchitinized (or at most represented by the prosicula, Fig. 45, 10) and the familiar early growth stages are replaced by the ancora and corona stages

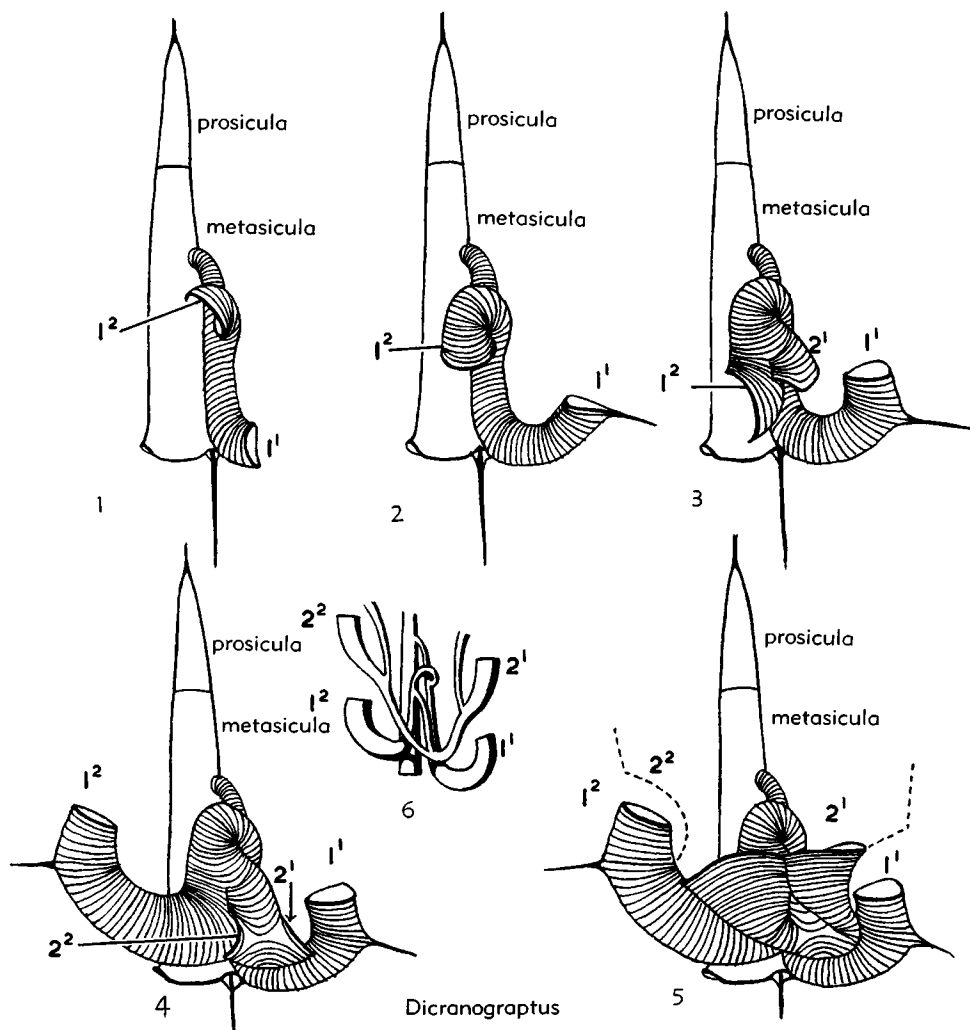

FIG. 43. Diplograptid type of development. Series of growth stages of *Dicranograptus nicholsoni* illustrating *dentatus* type, growth lines slightly schematic, ca. $\times 30$ (9).

(Fig. 45,1-5). Notable contributions have been made by EISENACK (1951), but so little of the rhabdosome is chitinized that the thecal succession remains almost impossible to interpret.

MONOGRAPTID TYPE

In the monograptid type (Fig. 46), a downward direction of growth no longer affects even the initial bud, and $th1^1$ grows upward from its first appearance; the rhabdosome is uniserial throughout (Monograptidae) or at least proximally (Dimorphograptidae). The origin of this development presents another unsolved problem. Failure to produce the 2 buds from, say, $th2^1$, would eliminate the secondary stipe but only produces the remarkable genus *Peiragraptus*. To convert the rhabdosome to a uniserial rhabdosome requires in addition that $th1^2$ either be reduced and lost, or be incor-

porated between $th1^1$ and $th2^1$ (Fig. 37). *Dimorphograptus*, with its proximally uniserial and distally biserial rhabdosome, cannot readily be regarded as an intermediate stage.

GRAPTOGONOPHORES

Extrathecal structures, variously termed "ovarian vesicles," "reproductive sacs," and "graptogonophores," have been figured and described, first by HALL (1859, 1865) in "*Graptolithus whitfieldi*" (referred by RUEDEMANN to *Hallograptus bimucronatus*) and later by HOPKINSON (1871) and NICHOLSON (1866, 1872) in *Diplograptus* spp. These early figures are schematic; some represent the scopulae of lasiograptids, a peculiar spinous or fibrous development from the edges of the median septum comparable with the lacinia, whereas others probably were vesicular, having a firm outline, and seem to

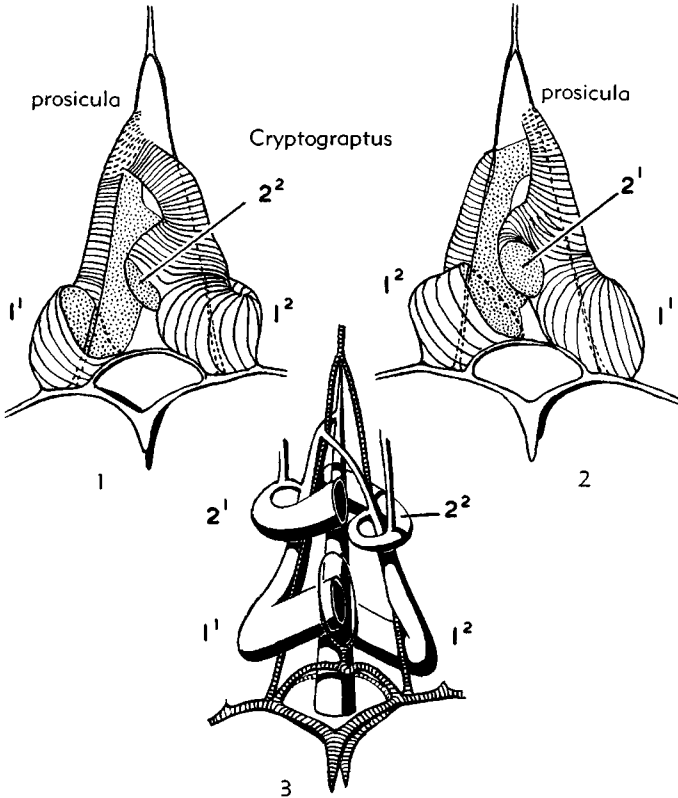

FIG. 44. Cryptograptid development illustrated by very early growth stage of *Cryptograptus tricornis* X20 (9). 1, Reverse view. 2, Obverse view, with thecal diagram and clathrial framework. Growth lines slightly schematic.

have been attached to the apertural region of otherwise normal thecae. Siculae and early growth stages may be abundantly associated with such specimens, and in some they appear to be attached to the vesicles by their nemas, though it is impossible to assert that they are not drifted into juxtaposition. Such capsules were claimed to represent ovicells, but their rarity and restriction to

biserial graptolites is curious, and no convincing interpretation has yet been given.

CLADIA

The Middle Silurian genus *Cyrtograptus* is characterized by its apparently branched rhabdosome, and something similar is becoming recognized as rather widespread among the Monograptidae. The relations

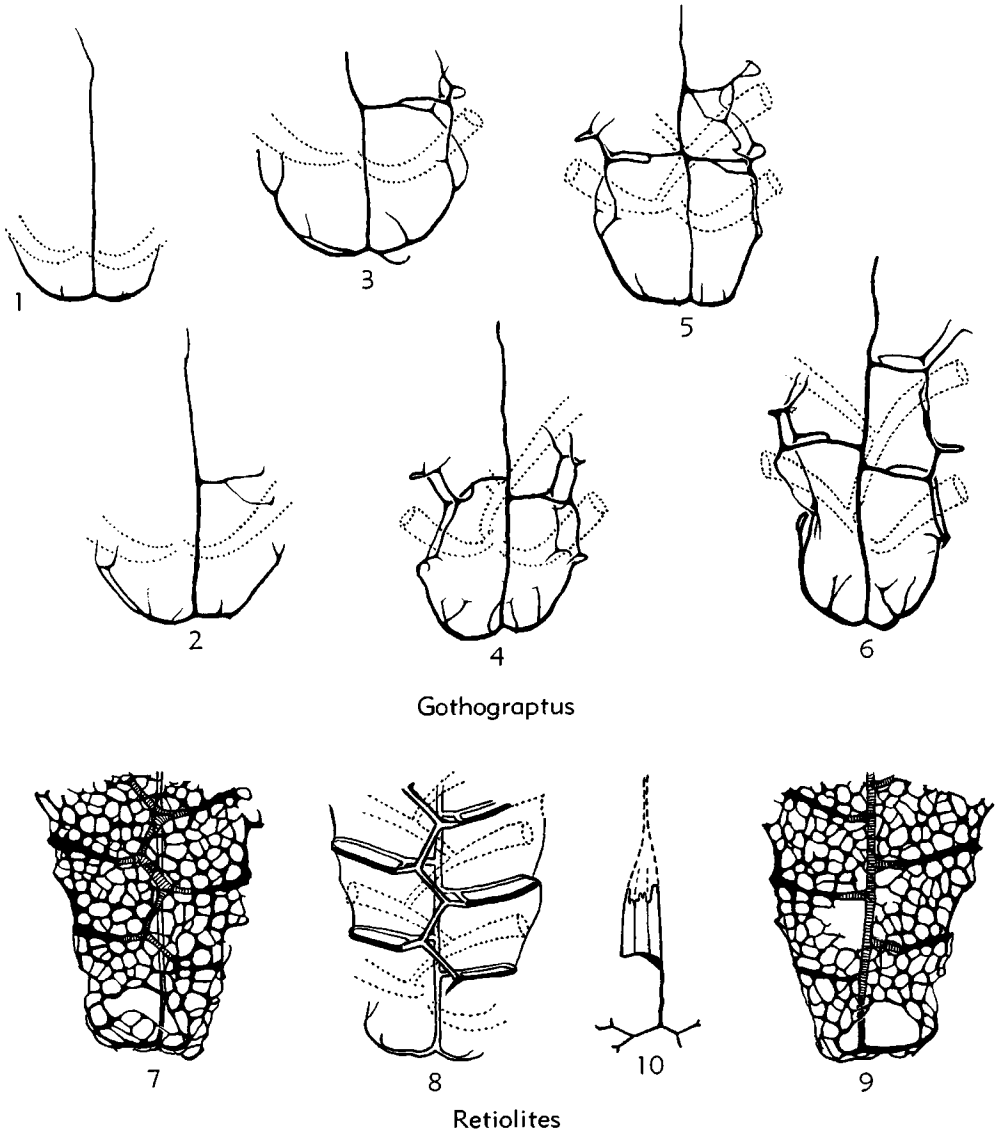

FIG. 45. Retiolitid development. 1-6, Series of growth stages of *Gothograptus tenuis* showing (1) ancora stage and (3) corona stage, ca. $\times 20$ (13). 7-9, Proximal end of *Retiolites geinitzianus* showing corona, reticula and clathria, $\times 20$ (82). 10, Proscicula and ancora stage of *R. geinitzianus*, $\times 20$ (82).

of the cladia to the main stipe have at last been made known through the work of THORSTEINSSON (1955) and stages in development, based on THORSTEINSSON'S data for *C. rigidus* var., are shown in Fig. 47. The first indication is commonly the elongation of one (obverse) of the lateral apertural spines of the mother theca, which is destined to become the virgula of the cladium. This is followed or accompanied by the appearance of the initial flange, and then the ventral hood, which by their ankylosis produce both the tubular initial portion of the cladium and a secondary aperture to the mother theca, the cladial activity retaining at the same time unrestricted communication with the cavity of the parent theca. The cladium appears, therefore, to be developed from an asexually produced bud on one of the main-stipe thecae.

For any given species, the thecal number of the mother theca (counted from the

proximal end) is nearly constant and a more or less constant number of thecae (some 3 or 4) are added to the distal end before the beginnings of cladial generation become manifest. Furthermore, the process of development outlined above occupies a time represented by the formation of several more thecae, so that by the time the first cladial theca is completed, the position of the mother theca has become 7th or 8th from the distal end. Progressive change in thecal form is usual in cyrtograptids and the characters of the first cladial theca correspond closely to those of the contemporary theca on the main stipe; subsequent growth of the cladium keeps in step with the main stipe and any further changes in thecal characters on the main stipe are paralleled by the cladial thecae (Fig. 47,6). Thus, at any time, thecae of the same size and shape are developing at both the free ends of the rhabdosome. The same principle seems to

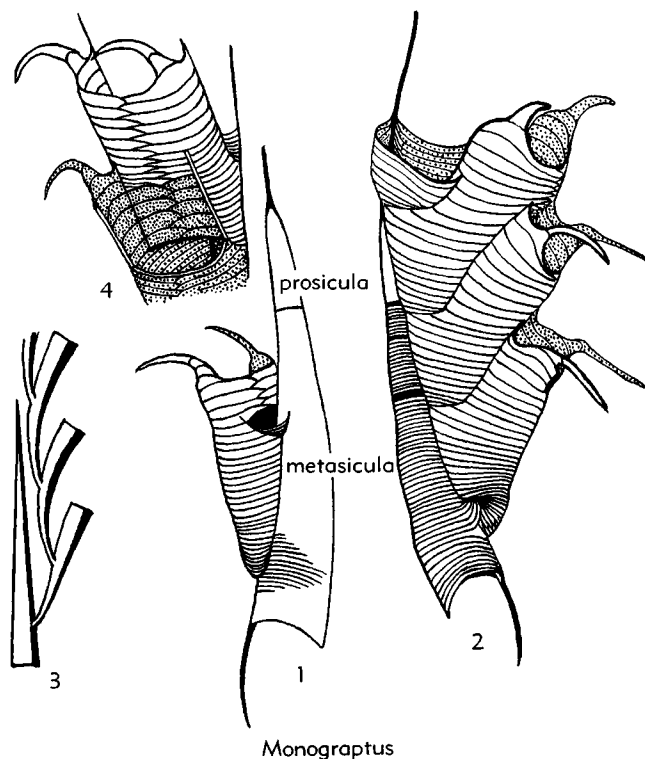

FIG. 46. Monograptid type of development illustrated by *Monograptus chimaera* (93). 1, 2, Early growth stages showing annular deposits in metasicula, primary notch and initial bud, and growth relations of successive thecae, $\times 30$. 3, Thecal diagram. 4, Diagram illustrating formation of interthecal septum.

apply to more complicated cyrtograptids and to those with cladia of several "orders." There does not appear to be any support for the assertion that cladia ever become free of their parent theca.

Comparable details of development for diversograptids are not at present available, but it appears (STRACHAN, 1952) that the bilateral *Diversograptus* rhabdosome results from something in the nature of a sicular cladium, and here possibly the virgella becomes the virgula of the cladial stipe. Nothing can be added regarding the structure of the still more complicated rhabdosomes of *Linograptus*, *Abiesgraptus*, and other genera.

SYNRHABDOSOMES

In 1865, HALL figured a stellate group of *Lasiograptus* [*Retiograptus*] *eucharis* united by their virgulae, and in 1895, RUEDEMANN described a large series of such associations belonging to various biserial graptolites and attempted to relate them to the life cycle. This paper of RUEDEMANN's still provides the best and most completely illustrated description of these synrhabdosomes, as he called them; but a new interpretation has lately been suggested by KOZŁOWSKI.

The synrhabdosome consists essentially of a stellate group of rhabdosomes in various stages of development, surrounding a cen-

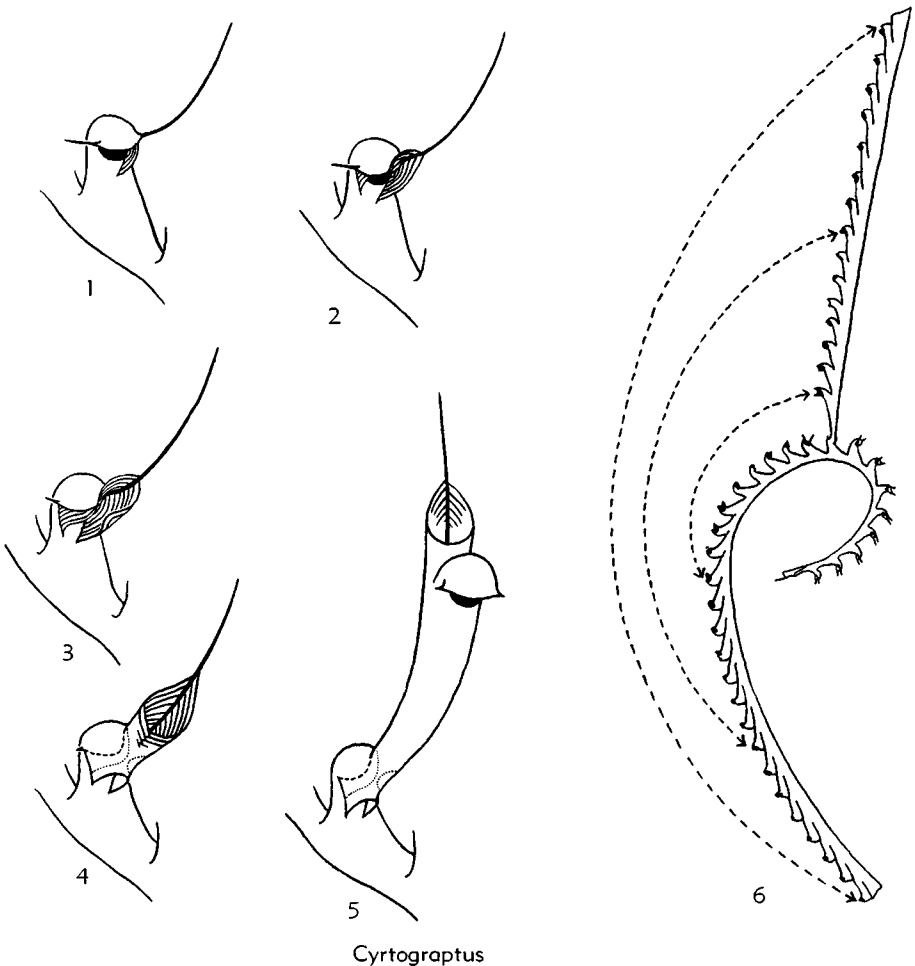

FIG. 47. Cladial generation in *Cyrtograptus rigidus* TULLBERG, var. (56). 1-5, Successive stages, somewhat schematic. 6, Diagram of mature rhabdosome showing thecal relations of cladium and main stipe, $\times 2$.

tral, almost square, chitinous disc; and in better-preserved specimens this squarish disc partially overlies and is surrounded by several oval or circular discs which apparently contain bundles of siculae. In addition to this more or less adult arrangement, however, a series of immature stages was described: a single sicula or a single rhabdosome attached by its virgula to the squarish disc (Fig. 48,1); groups of siculae or very young rhabdosomes so attached (Fig. 48, 2-4); and finally groups of rhabdosomes in all stages of development attached to the disc, with the subsidiary oval discs and their included siculae (Fig. 48,6). RUEDEMANN named the oval discs gonangia, and considered that the central disc was in fact a vesicle or float; but it might have been adhesive (a disc of attachment).

According to KOZŁOWSKI (1949), a clue to the interpretation of these synrhabdosomes is to be sought in the formation of buds on the peduncle (in some on a sterile peduncle) in *Cephalodiscus*. Admittedly these buds, though they may be so numerous as to form a circllet, do not remain attached to

the maternal zooid, but in *Cephalodiscus* the organism itself does not form true colonies. The suggestion then is that synrhabdosomes result from a comparable process of budding from the apical portion of the original sicula, the buds here remaining associated. If this is true, the siculae of synrhabdosomes are not strictly comparable with the sexually produced siculae of normal rhabdosomes and should lack a differentiated prosicula portion; this point has not yet been verified. Such asexually produced siculae were termed pseudosiculae by KOZŁOWSKI.

Synrhabdosomes are comparatively rare, and are known only in a few species of biserial graptolites.

EVOLUTIONARY TRENDS AND FAUNAL SUCCESSION

Graptolites illustrate perhaps better than any other group the operation of comparatively few guiding trends, the recognition and stratigraphical application of which is largely due to the work of ELLES (1922).

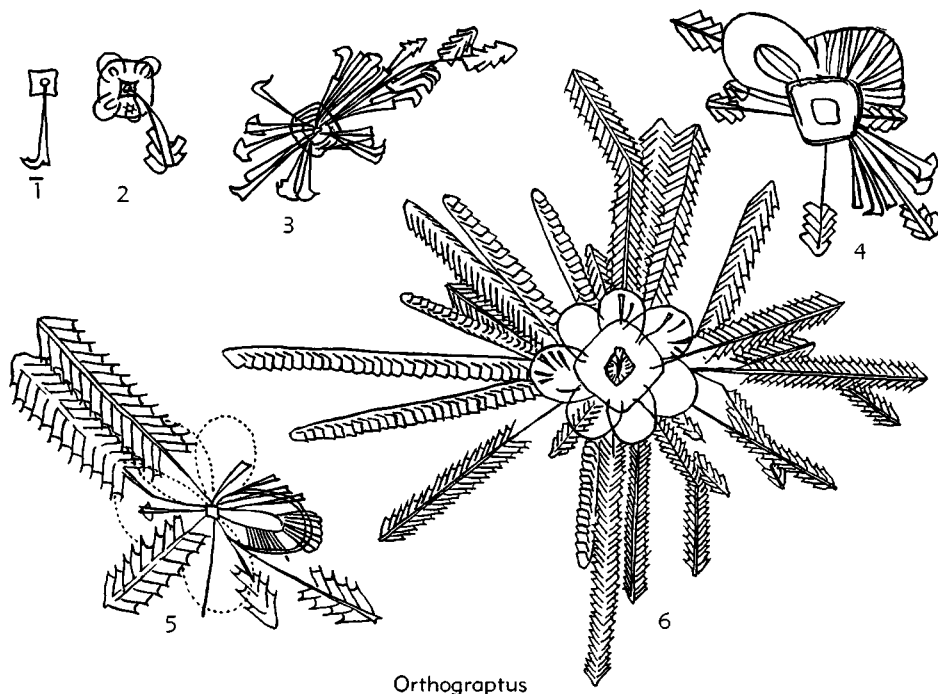

FIG. 48. Development of synrhabdosome in *Orthograptus* sp. (49). 1-4, Successive stages, $\times 3$. 5, Partially developed synrhabdosome, $\times 4$. 6, Fully developed synrhabdosome, $\times 1$.

These influence the whole aspect of successive graptolite faunas to an extent that at least approximate age determination can be made with a minimum of specific identification. Most important of these trends are reduction in number of branches (reaching a very stable phase of 2 in the later Ordovician and eventually one in the Silurian); and change in direction of growth (relative to the nema) from pendent or horizontal to reclined and scandent. Others involve changes in the proximal end (p. V49), phases of thecal elaboration, especially in monograptids (p. V63), and possibly certain aspects of secondary thickening of the periderm.

DICHOGRAPTID FAUNA

The earliest graptolite fauna of the Tremadocian consists of forms here referred to the Dendroidea under the family Anisograptidae; but slightly higher in the Tremadoc these are joined (in Scandinavia, Canada, and New Zealand) by species of small *Didymograptus*.

Above this, in the Arenigian (lower *Didymograptus* shales, lower Deepkill, etc.), the horizontal series of dichograptids is dominant, being represented by some multiramous forms, horizontal tetragraptids and especially the extensiform didymograptids; pendent tetragraptids and the forerunners of the pendent didymograptids (descendants of the *Bryograptus* line) occur to a lesser extent. The higher parts of the Lower Ordovician (Llanvirn, upper *Didymograptus* shales, upper Deepkill, etc.) is characterized by the dominance of the tuning-fork graptolites, whose evolution was slower than that of the extensiform series; but extensiform *Didymograpti* persist along with multiramous forms and biserial graptolites (*Glyptograptus dentatus* series and cryptograptids) become more abundant.

In Australia, there is less emphasis on extensiform *Didymograpti*, though these are a significant component of the Lower Ordovician (Bendigonian). The earliest faunas are better expressed in terms of the pendent reduction series, although the later members of that series are not conspicuous. The Bendigonian is characterized by horizontal multiramous forms with 4- and later 3-branched *Tetragraptus fruticosus*; the Chew-

tonian by *Didymograptus protobifidus*; the Castlemainian by isograptids, and the Yapeenian by *Oncograptus* and *Cardiograptus*.

LEPTOGRAPTID FAUNA

In the leptograptid fauna as a whole (Glenkill, Normanskill, lower *Dicellograptus* shales, etc.), the dichograptid type of theca, hitherto almost universal, now becomes generally replaced by the sigmoid leptograptid type, and the bulk of the genera are simple 2-stiped reclined forms (except for *Nemagraptus*). Scandent biserial graptolites, especially *Glyptograptus*, *Climacograptus* and *Amplexograptus*, become increasingly abundant.

DIPLOGRAPTID FAUNA

The beginning of this fauna (Hartfell, Canajoharie, Utica, middle and upper *Dicellograptus* shales, etc.) is marked by the sudden profusion of diplograptids, particularly orthograptids.¹ *Dicranograptus* is also characteristic, with abundant *Dicellograptus*; these 2 genera exhibit their more elaborate thecal types in the lower and middle part of the beds containing them, apparently reverting to simpler thecal types in the upper portion where the fauna has some of the characteristics of an impoverished fauna (upper Hartfell, Polk Creek, etc.). It persists, minus the axonolipous element, into the base of the Silurian, the lowermost zones of which are characterized by biserial forms along with *Dimorphograptus*.

MONOGRAPTID FAUNA

Silurian. The monograptid fauna is introduced by the profuse development of monograptids slightly but appreciably above the base of the Silurian. Subdivision may be accomplished, principally by reference to thecal type, as follows:

(1) Lower Silurian (Llandovery). (a) Dominance of *Monograptus* of simple thecal type with numerous biserial forms (*Orthograptus*, *Climacograptus*) and *Dimorphograptus* at the base. (b) Dominance of isolate and lobate thecal types among monograptids, and waning of diplograptids. (c)

¹ In most North American faunal lists, the dominance of Orthograpti is obscured by the reference of many species to *Glossograptus*.

Acme of isolate type (*Rastrites*) and dominance of hooked type.

(2) Middle Silurian (Wenlock). Acme of hooked type (*Monograptus priodon*, etc.)

and dominance of cyrtograptids.

(3) Upper Silurian (Lower Ludlow). Dominance of monograptids of simple thecal type.

CLASSIFICATION

PRINCIPLES

The early graptolite genera were founded upon easily recognized features of gross morphology, such as distinctive general form (*Phyllograptus*, *Dicranograptus*), number of branches (*Tetragraptus*, *Dichograptus*, *Monograptus*), or biseriality (*Diplograptus*); occasionally some more minute feature, such as reticulate periderm (*Retiolites*), was utilized, but only rarely were thecal characters employed (*Rastrites*, *Climacograptus*). Thecal characters, including number and size, as well as shape, have been very generally used in specific discrimination, however, often leading to segregation of specific groups within a genus. Thecal characters, usually in combination with other features, have more recently been used generically, as in subdivision of the diplograptids, but it remains broadly true that genera are founded upon characters of the rhabdosome as a whole, while discrimination of species commonly rests largely upon thecal characters.

This procedure had the merits of expediency and has served to keep the total number of genera within reasonable limits, but it has one serious defect. Most of the characters which determine gross morphology seem to be the result of parallel evolution, and in consequence, nearly all graptolite genera, as they have been defined, are polyphyletic. Thecal characters may provide a clue to true phylogeny, but even thecal characters, alone, are not necessarily a safe guide, for thecal trends are recognizable, particularly in the monograptids. Only by the use of all possible characters can probable phylogenetic lines be disentangled and our knowledge is still far from sufficient to attempt the subdivision of existing genera on a basis of true phylogeny. For this reason, the recent Continental tendency to name the species groups (of LAPWORTH, ELLES, and WOOD) within such genera as *Monograptus*, *Orthograptus*, or even *Didymograptus*, is to be

deprecated. Such genera may be large, and are admittedly polyphyletic, but by the use of their names "one is at least told the grade of structure" (BATHER, 1927).

Another difficulty of practical sort may arise from the delicacy of most graptolite rhabdosomes and their manner of preservation. Structural details can only be discerned in material preserved in full relief, and best in preparations made by the solution of a limestone or chert matrix. Such material is rare and its distribution among the whole range of graptolites is capricious. It may afford hints of a more satisfactory basis of classification than the one currently in use (e.g., EISENACK's work on retiolitids); yet the application of such improved classification may remain impracticable simply because it cannot be applied to normal imperfectly preserved specimens in shale. Even specimens preserved in full relief may be difficult to identify when the species has previously only been known from crushed material.

PHYLOGENY

Dichograptidae. The most comprehensive of all graptolite families is the *Dichograptidae*, containing nearly 30 valid genera of very diverse appearance. An attempt was recently made (BULMAN, 1950) to restrict this assemblage slightly and unify it by removal of bitheca-bearing genera to the *Dendroidea* under the family *Anisograptidae*; this course, though not wholly satisfactory, is followed here. The *Anisograptidae* is a family so completely transitional between the *Dendroidea* and *Graptoloidea* that it could be included in either, for the mode of life appears to have been graptoloid, whereas the branch structure remains characteristically dendroid. It is true that bithecae seem to be lost in Ordovician species of *Clonograptus* and have not been conclusively proved in *Bryograptus*, but the inclusion of 1 or 2 forms without bithecae in a dendroid family involves no greater

inconsistency than the inclusion of several with bithecae in a graptoloid family. The position will be unsatisfactory whatever procedure is adopted, for the connection with *Dictyonema* is at least as close as that with later multiramous dichograptids, as here restricted. One effect of removing *Clonograptus* and *Bryograptus* (with other genera) to the Dendroidea is to emphasize the polyphyletic origin of the Dichograptidae; but this could only be avoided, if at all, by extending the Dichograptidae to include *Dictyonema flabelliforme* (*sensu lato*).

It was through their work on certain dichograptids that NICHOLSON & MARR (1895) first recognized the possibility that graptolite genera might be polyphyletic.¹ To these authors, the number of branches in a graptolite rhabdosome (though forming the basis of so many earlier generic definitions) was a feature of less importance than thecal characters, and using the criterion of thecal similarity and (to a less extent) angle of divergence, they recognized 9 groups of *Didymograptus*, *Tetragraptus*, *Bryograptus*, and *Dichograptus* species as establishing the principle of stipe reduction. They stated: "It is comparatively easy to explain the more or less simultaneous existence of forms possessing the same number of stipes, but otherwise only distantly related, if we imagine them to be the result of variation of a number of different ancestral types along similar lines" (p. 537). They were aware that the phylogenies postulated were probably oversimplified, remarking that "it is probable that a whole group of species sprang from an earlier form which possessed a greater number of branches than its descendants" (p. 535), and in 4 of their 9 groups, the multiramous ancestor was "an unknown *Dichograptus*."

The principle thus propounded found favor in the writings of RUEDEMANN, ELLES, and most other authorities. The sequence became extended to include *Clonograptus* and *Loganograptus*; and irregular rhabdosomes of *Loganograptus* and *Dichograptus* lacking the full complement of branches

(although many of these occur at high stratigraphical levels) were regarded as intermediate stages. To stabilize the position as regards generic definition, ELLES & WOOD (1902) laid emphasis on the order of branches present, rather than the precise number of branches, saying, "It is not the actual number of stipes, but the degree of capacity for dichotomy which is the essential characteristic of the genus" (p. 81).

While doubtless valid in certain instances, this well-known series, *Clonograptus-Loganograptus-Dichograptus-Tetragraptus-Didymograptus*, has been challenged recently by Australian workers (especially HARRIS & THOMAS) as a principle of wide application. They have shown the probability that *Tetragraptus* and even *Didymograptus* may arise directly from multiramous ancestors (e.g., *Schizograptus* and *Trochograptus* by way of *Mimograptus*); and while *Dichograptus* may be of fairly common occurrence as an intermediate in the chain, there is no evidence that the 16-branched (*Loganograptus*) stage "marked a degree of stability comparable with that represented by the typical *Dichograptus* eight-branched stage."

Some of the possible lines of descent are indicated in an accompanying table (Fig. 49), which at present must be regarded as purely tentative, for the systematic grouping of dichograptid genera makes claim to be little more than a key.

That reclined tetragraptids have given rise to the scandent *Phyllograptus* can scarcely be doubted, but the distinctive *Tetragraptus phyllograptoides*, though morphologically intermediate, does not seem to represent a phylogenetic link. On the other hand, the relationship of *Isograptus* to *Oncograptus* and *Cardiograptus* is anomalous. Their stratigraphical relations indicate analogy with the *Tetragraptus-Phyllograptus* development, but the only *Oncograptus* investigated in detail (from the Marathon limestone of Texas) possesses a proximal end far more primitive than any known *Isograptus*. *Skiagraptus* is structurally unknown but is provisionally regarded as another biserial dichograptid. *Azygograptus* and *Parazygograptus* represent the end terms of stipe reduction acting on axonolipous rhabdosomes.

¹ WIMAN (1895) seems independently to have postulated a polyphyletic origin for *Monograptus*, regarding some of the different thecal types as implying a distinct ancestry, but he gave no details.

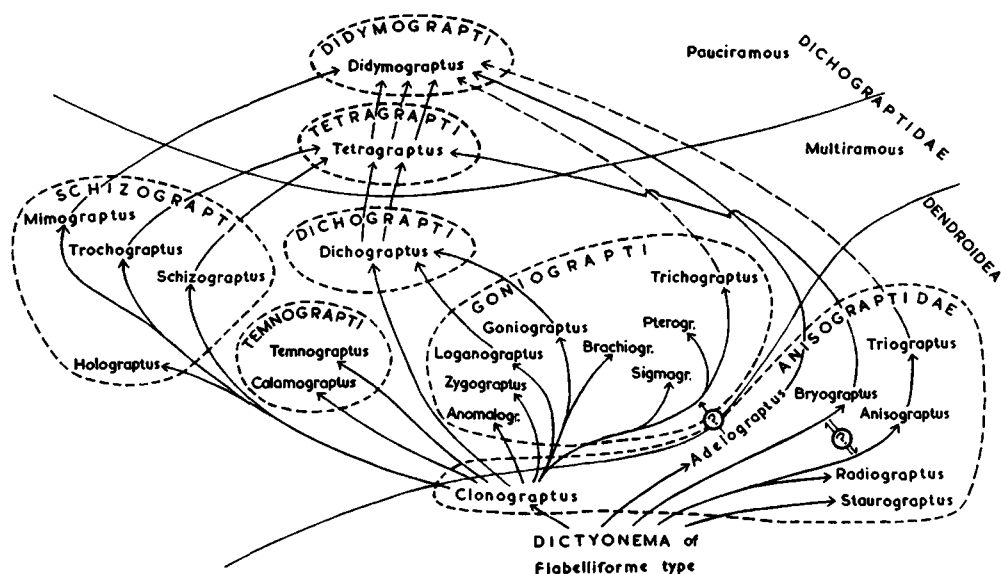

FIG. 49. Phylogeny of *Tetragraptus* and *Didymograptus* (tentative), with suggested grouping of the principal multiramous dichograptid genera and possible relations to the Anisograptidae.

Corynoididae. By the very simplicity of its organization the genus *Corynoides* occupies an isolated position, and the limited number of thecae (not more than 3 in any species) suggests degeneracy or arrested development. The length of the sicula, high position of the initial bud, and alternating origin of the 2 or 3 thecae might indicate derivation from an isograptid ancestor; however, it is separated from that genus by a considerable time interval and the distinctive characters of the thecae are not closely paralleled in any other graptolite.

Leptograptidae. Derivation of the simple *Leptograptus* from extensiform *Didymograptus*-stock presents few difficulties; the leptograptid type of theca is foreshadowed in several *Didymograptus* species, and in an advanced stage of isograptid development the alternating mode of origin of the first 3 or 4 thecae is comparable. But the branched leptograptids are more problematic; their detailed structure has never been described and they possibly arose in more than one way. The occurrence of a few centribrachiote mutations of several species of *Leptograptus* (mostly from the *linearis* zone) suggests an inherent tendency of the stock which might suffice to explain the origin of *Amphigraptus* and

perhaps *Pleurograptus*. On the other hand, *Nemagraptus* may equally well represent a persistent multiramous stock descending from *Sigmagraptus* or some allied form; and even as regards *Amphigraptus*, that genus occurs much lower in North America (Normanskill) than in Europe, and the Normanskill *Syndyograptus* possibly affords a hint of multiramous dichograptid origin.

Dicranograptidae. The derivation of *Dicellograptus* from *Leptograptus* would require but slight changes in mode of development, and early *Dicellograptus* thecae represent little advance upon the leptograptid type; nevertheless *Dicellograptus* occurs considerably earlier than the oldest known *Leptograptus* and an independent origin from dichograptid stock cannot be excluded. *Dicranograptus* is still more problematic. Its initially biserial character generally has been considered to represent an intermediate stage between *Dicellograptus* and a diplograptid, in fact constituting one of several lines of diplograptid descent. Details of the mode of development in *Dicranograptus nicholsoni* (the only species fully known) has cast doubt on this, for this development presents several features reminiscent of the archaic *Glyptograptus dentatus* which are lost in post-Arenig diplograptids and are

unknown in *Dicellograptus*. Moreover, there is no indication that the length of the biserial portion shows any regular tendency toward increase with geological time, and the various species, though showing slight fluctuations, give rather the impression of relatively stable mutations, commonly ranging with negligible change through several graptolite zones.

Biserial graptolites. The "diprionidian" or biserial graptolites form an exceedingly heterogeneous collection, falling into at least 5 families.

Merely by fusion of the dorsal walls of a reclined didymograptid it would be possible to produce a biserial rhabdosome, irrespective of the stage reached in mode of development, and such "biserial dichograptids" are now recognized in such genera as *Onco-graptus* (only partially biserial), *Cardio-graptus*, and probably *Skiagraptus*. Such forms remain essentially dichograptids and are here retained in the family Dichograptidae.

Cryptograptus is so sharply marked off from the typical diplograptids (amongst which it was originally included) as to require the erection of a separate family, and

in some respects this, too, is little more than a biserial dichograptid. Details of the proximal end of *Glossograptus* remain unknown, but it seems to be essentially similar to *Cryptograptus*, and so we follow HADDING in placing these 2 genera in the same family.

The Diplograptidae proper comprised originally the 2 genera, *Climacograptus* and *Diplograptus*, the latter now split into several genera; and this family is characterized by a mode of development in which at least the first 4 thecae are alternating in origin. *Glyptograptus dentatus* appears in the Arenig as a cryptogenetic type, which seems as if it might be ancestral to most of this family; and in the absence of definite evidence to the contrary, it is so indicated in the provisional phylogenetic table (Fig. 50). Characteristics of the *G. dentatus* development are related to more general diplograptid development; the thecae are strongly sigmoidal, and from this both the simpler (orthograptid) and more sharply angular (climacograptid) types seem to have arisen. Attention should be called to the break in continuity of *Glyptograptus* and *Diplograptus* (*Diplograptus*) between the Ordovician and Silurian (Fig. 5), which may indicate

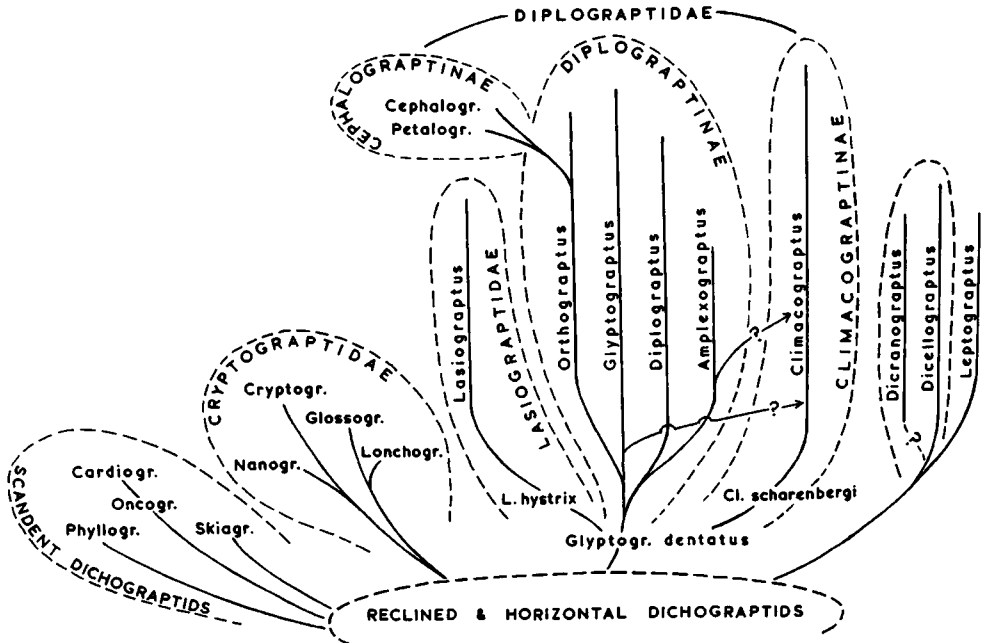

FIG. 50. Phylogeny of the principal genera of biserial graptolites (tentative).

that forms assigned to these genera have originated more than once.

Within *Climacograptus* and various diplograptid genera, species groups were long ago recognized (ELLES & WOOD, 1907, etc.) and it is apparent that many of these reflect considerable and significant structural differences. Such groups, however, intentionally were left unnamed (like the *Dimorphograptus* and *Monograptus* species groups) in the hope that subdivision might eventually be made on the basis of true phylogeny when sufficient evidence had accumulated. The recent application of subgeneric names to these groups, without any addition to knowledge, is considered premature; and although technically valid, these subgenera are cited as synonyms in the taxonomic section that follows.

The Lasiograptidae are here considerably

restricted by the removal of *Glossograptus* and *Reteograptus*, but very possibly they still constitute a polyphyletic assemblage. They originated early in the Ordovician, and at least in part, seem derivable from *Glyptograptus dentatus*.

Much new evidence has come to light recently concerning the Retiolitidae, but it is not yet possible to indicate any definite genetic grouping and they are placed in 3 subfamilies as a matter of taxonomic convenience only. The Ordovician Archiretiolitinae are probably not true retiolitids, and the Plectograptinae may themselves represent several lines of descent.

Dimorphograptidae. The genus *Dimorphograptus* generally has been regarded as intermediate between the diplograptids and *Monograptus*, since it is uniserial proximally and biserial distally; moreover, it is essen-

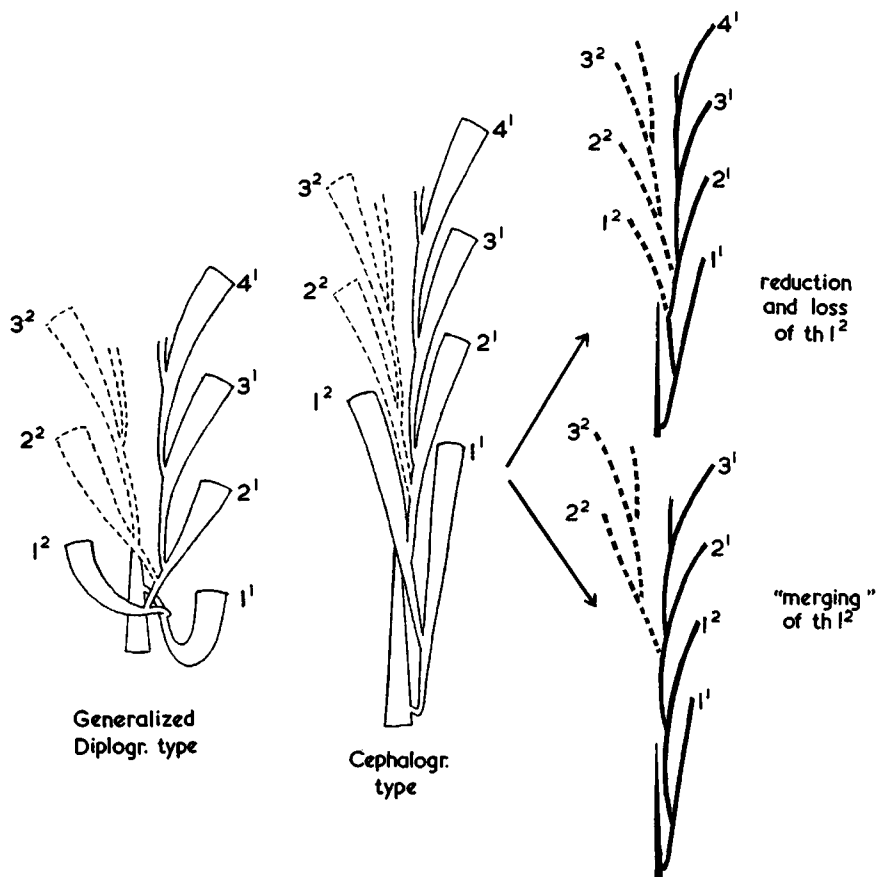

FIG. 51. Diagram illustrating the problem of monograptid origin (72).

tially premonograptid in range. However, its position is very uncertain and it is discussed below under the origin of *Monograptus*.

Monograptidae. Failure to produce the pair of buds, or more exactly, the production of a single bud in place of the pair, cannot by itself convert a diplograptid into a *Monograptus*, for even in the simplest and most generalized diplograptid, the first 4 thecae of the rhabdosome alternate in origin (Fig. 51,1). This is demonstrated by STRACHAN's recently described *Peirograptus*, which exhibits a uniserial rhabdosome apart from $th1^2$ which occurs in its normal diplograptid relation. The change can only be effective after the proximal thecae have substituted a linear arrangement for the alternating arrangement of their diplograptid ancestor. This might arise either by reduction and loss of $th1^2$ and any later "second-order" thecae (Fig. 51,3) or by a "merging" of the thecae of the 2 series (Fig. 51,4), as postulated by WIMAN. Such merging would be combined with the pronounced tendency to an upward direction of growth which affects also the biserial *Petalograptinae* (Fig. 51,2).

Starting from a diplograptid with the most generalized proximal end (a complete septum), it would only be necessary to lose one theca ($th1^2$) or to get $th1^2$ into series between $th1^1$ and $th2^1$, for a subsequent failure of the "double bud" to result immediately in a monograptid rhabdosome (Fig. 51,3,4). The origin of *Monograptus* thus can be seen essentially to present question of the disposal of $th1^2$. The rearrangement, or loss, of numerous proximal thecae in a biserial ancestor with numerous alternating proximal thecae and a delayed septum is more difficult to understand. Yet such must have occurred if *Dimorphograptus* is a true intermediate; and furthermore, the well-defined species groups of *Dimorphograptus* imply that if this was their origin, the change must have occurred several times in independent lines of descent. It may be thought therefore that *Dimorphograptus*, with a uniserial portion commonly of very considerable length, is more likely to be an atavistic form (as WIMAN suggested) or a short-lived sideline than a normal intermediate between *Diplograptus* and *Monograptus*.

With the origin of the monograptids, only a little more than halfway through the geological history of the Graptoloidea, the major phases of structural evolution of the graptolite rhabdosome are completed. The development of the cladia-bearing rhabdosomes of the *Cyrtograptinae* seemingly represent the only rhabdosomal changes still possible. These are in the main a Middle and Upper Silurian development, and seem to represent a sort of trend, paralleling the leptograptid reversion to multiramous rhabdosomes. Thecal elaboration affects the monograptids to an extent exceeding any modifications known in the Ordovician, and it has been remarked that almost invariably there appears an exaggerated development here of the *dorsal* margin of the theca (leading to extroverted thecal forms) quite distinct from the dominant development of the *ventral* lip (and introverted thecae) seen in the Ordovician. Problems of thecal elaboration (and particularly the so-called retrogressive series) are only beginning to be investigated in detail, and it is not yet possible to indicate any phylogenetic grouping. For this reason it is considered desirable to retain the use of the generic term *Monograptus* in its wide sense.

SYSTEMATIC DESCRIPTIONS

Family DICHOGRAPTIDAE Lapworth, 1873

Rhabdosome bilaterally symmetrical, branching dichotomous or lateral, central disc present in some; pendent to scandent, usually declined or horizontal; stipes uniserial, rarely biserial or quadriserial; thecae typically simple, straight or with slight ventral curvature, denticulate, overlapping about one-half their length; development of dichograptid or isograptid type. *L.Ord.*(*Tremadoc.*)-*M.Ord.*

MULTIRAMOUS FORMS

Pendent to horizontal, rarely reclined; branching dichotomously to produce at least third-order branches (first-order branches constitute the "funicle" of HALL), or laterally from one or both sides of 2 or 4 main stipes. *L.Ord.*

Section GONIOGRAPTI

Based on didymograptid or tetragraptid foundation, with compact regular branching either dichotomous or lateral. *L.Ord.*

Goniograptus M'Coy, 1876 [**Didymograpsus thureauii*]. With 4 zigzag main stipes, from angles of which undivided lateral stipes are produced with great regularity, so that form suggests regularly alternating dichotomy (in one subspecies dichot-

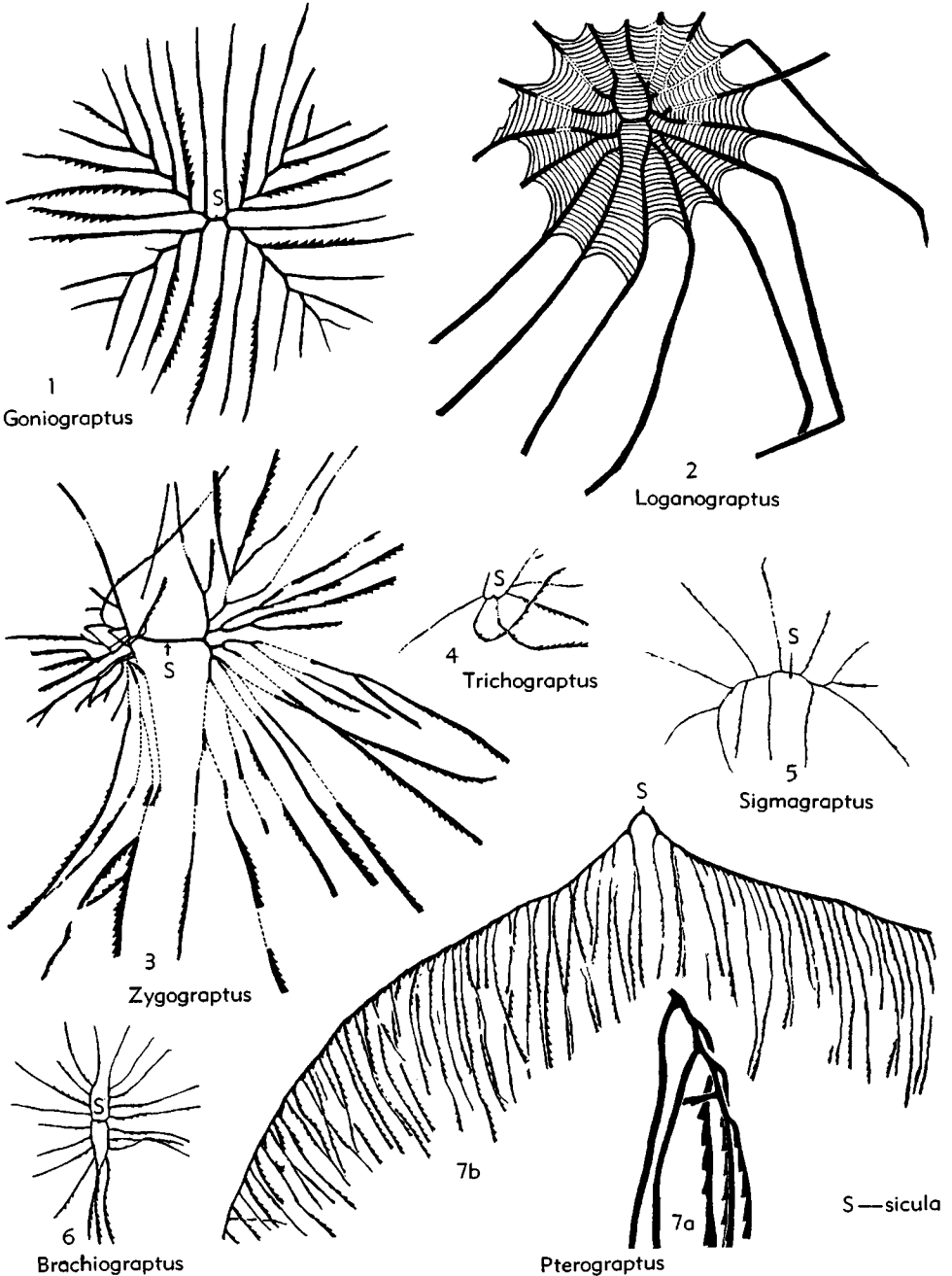

FIG. 52. Dichograptidae, Goniograpti (p. V75-V76).

omous division does occur in some quadrants); thecae with low inclination and slight overlap. *L.Ord.*, N.Am. (Deepkill - ?Normanskill) - N.Z. - Austral. (Bendigon - Castlemain.) - ?NW. Eu. — FIG. 52, 1. **G. thureaui*, Austral.; $\times 1$ (83).

Anomalograptus CLARK, 1924 [**A. reliquus*]. Late aberrant clonograptid with asymmetrical and irregular dichotomies up to 6th order. *L.Ord.* (*dentatus* z.), Que.

Brachiograptus HARRIS & KEBLE, 1932 [**B. etaformis*]. Small, composed of 4 main branches forming with funicle a letter H, from outer sides of which are produced close-set undivided lateral branches; thecae slender, with low inclination and slight overlap. *L.Ord.* (*Llanv.*), N.Am. - S.Am. - Austral. - ?Asia. — FIG. 52, 6. **B. etaformis*, Austral. (Darriwil); $\times 1$ (24).

Loganograptus HALL, 1868 [**Graptolithus logani* HALL, 1858]. Typically 16 to 8 branches, rarely exceeding 4th order, produced by proximally concentrated dichotomy; undivided terminal stipes mostly long and flexuous; central disc commonly present, enclosing proximal dichotomies; thecae moderately inclined with overlap of about one-half. *L.Ord.* (*L. Arenig.-Llanv.-?Normanskill*), NW. Eu. - N.Am. - Austral. - N.Z. — FIG. 52, 2. **L. logani* (HALL), Levis sh., Que.; $\times 1$ (21).

Pterograptus HOLM, 1881 [**P. elegans* (= *Graptolithus gracilis* KJERULF, 1865; non HALL, 1847)]. Pendent or declined, consisting of 2 primary stipes, each giving rise to undivided lateral branches alternately to right and left, forming a somewhat flabelliform rhombosome; thecae denticulate, inclined at moderate angles. *L.Ord.* (*U. Are-*

nig.-Llanv.), NW. Eu. - S.Am. - Austral. — FIG. 52, 7a. **P. elegans*, *U. Didymogr.* sh., S.Swed.; $\times 4$ (75). — FIG. 52, 7b. *P. scanicus* MOBERG, *U. Didymogr.* sh., S.Swed.; $\times 1$ (75).

Sigmagraptus RUEDEMANN, 1904 [**S. praecursor*]. With 2 slender main branches from which slender undivided lateral branches originate alternately on both sides (genus is essentially a 2-stiped *Goniograptus*); thecae extremely slender, inclined at low angles and with slight overlap. *L.Ord.*, N.Am. (Deepkill) - Austral. - N.Z. (Bendigon.) — FIG. 52, 5. **S. praecursor*, Deepkill, N.Y.; $\times 1$ (50).

Trichograptus NICHOLSON, 1876 [**Dichograptus fragilis* NICH., 1869]. With 2 slender primary stipes, straight or flexuous, originating at about 180 degrees from sicula, with slender undivided lateral branches regularly produced from one side only; thecae elongate with low inclination and very slight overlap. *L.Ord.* (*Arenig.-Llanv.*), NW. Eu. - S.Am. - Austral. — FIG. 52, 4. **T. fragilis*, Skiddaw sl., N.Eng.; $\times 1$ (17).

Zylograptus HARRIS & THOMAS, 1941 [**Graptolithus abnormis* HALL, 1857]. With 2 long first-order stipes forming an exaggerated funicle, followed by repeated dichotomies at close intervals to 5th or higher order; thecae with moderate to low inclination and slight overlap. *L.Ord.* (*Arenig.-Llanv.*), Austral. - N.Am. - ?N.Z. — FIG. 52, 3. **Z. abnormis* (HALL), Levis sh., Que.; $\times 1$ (53).

Section TEMNOGRAPTID

Widely and evenly spaced dichotomous branching based on a tetragraptid founda-

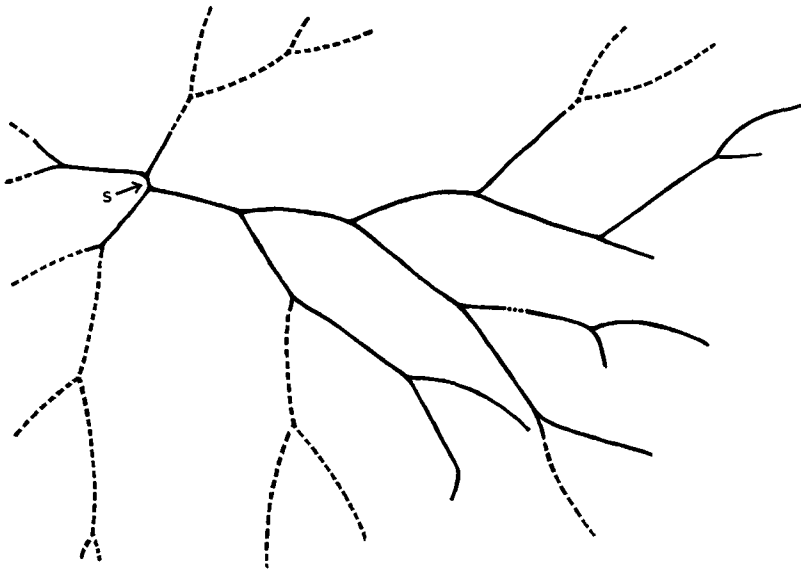

FIG. 53. *Dichograptidae*, *Temnograptus* (p. V77).

tion; rhabdosome usually of large size. *L.Ord.*

Temnograptus NICHOLSON, 1876 [**Dichograpsus multiplex* NICH., 1868]. Like *Clonograptus*, produced by regular dichotomous division but more consistently divergent, with very short funicle and long 2nd-order stipes, successive later orders being approximately equal in length to 2nd; thecae denticulate with moderate inclination and one-half to two-thirds overlap. *L.Ord.*, NW.Eu. (Are-

nig.)-N.Am. (?Athens).—FIG. 53. **T. multiplex*, *Didymogr.* sh., S.Swed.; $\times 0.7$ (61). **Calamograptus** CLARK, 1924 [**C. porrectus*]. Like *Temnograptus* but with branches of 2nd order very long, higher orders slightly decreasing in length. *L.Ord.* (*Levis*), Que.

Section SCHIZOGRAPTI

Usually of large size, based on either didy-mograptid or tetragraptid foundation, with

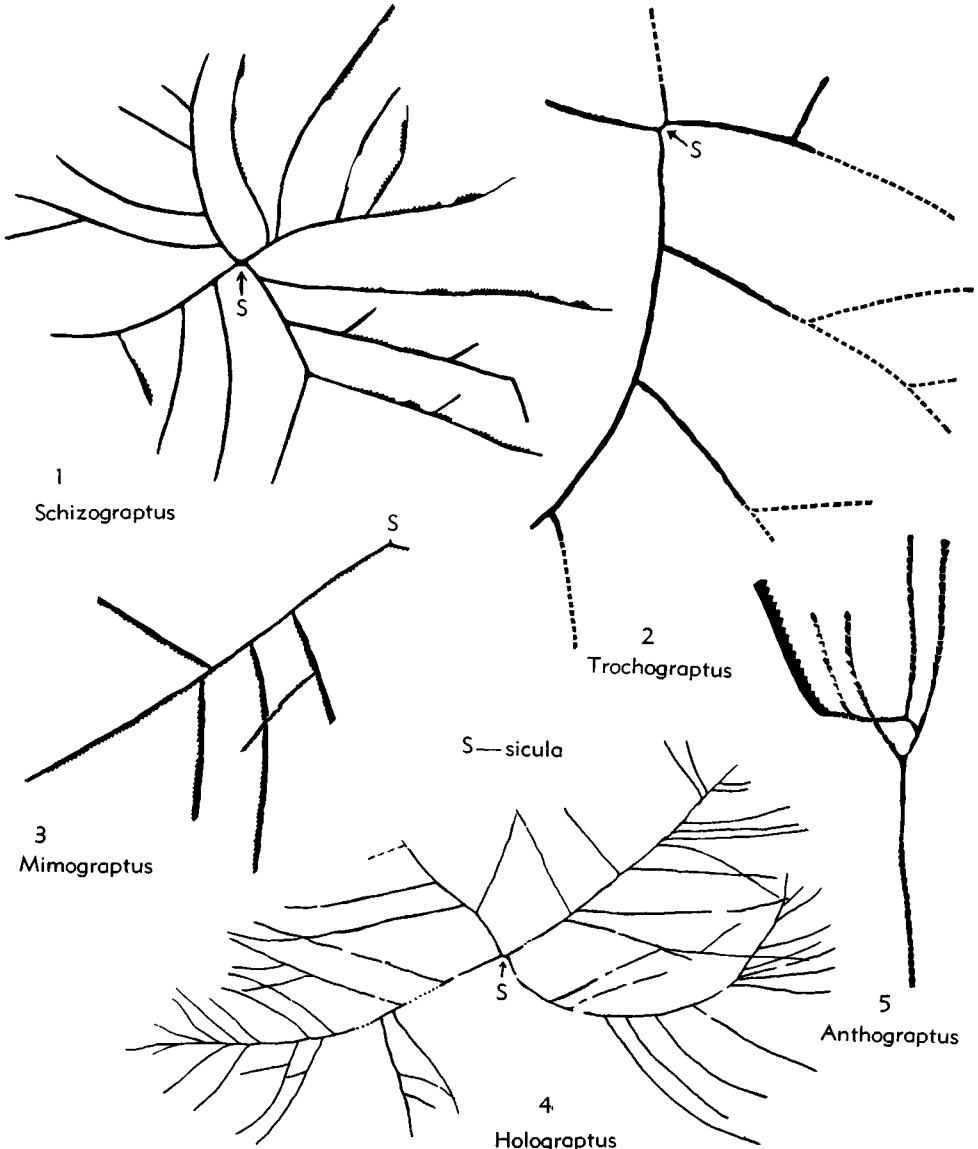

FIG. 54. Dichograptidae, Schizograpti (p. V78).

laterally produced secondary branches.
L.Ord.

Schizograptus NICHOLSON, 1876 [**Dichograptus reticulatus* NICH., 1868]. Rhabdosome based on 4 main stipes produced by dichotomous division from short funicle; lateral branches on one side only of main stipe; tertiary lateral branches rarely developed. *L.Ord.* (*Arenig.*), NW.Eu. - N.Am. - ?S.Am.-Austral.—FIG. 54,1. *S. rotans* TÖRNQUIST, *Didymogr.* sh., S.Swed.; $\times 0.7$ (61).

Holograptus HOLM, 1881 [**H. expansus*] [= *Rouvilligraptus* BARROIS, 1893]. Like *Schizograptus* but lateral branches produced somewhat irregularly from both sides of 4 main stipes, particularly distally. *L.Ord.* (*Arenig.*), NW.Eu.-Bohemia.—FIG. 54,4. *H. deani* ELLES & WOOD, Skiddaw sl., N.Eng.; $\times 0.13$ (17).

Mimograptus HARRIS & THOMAS, 1940 [**M. mutabilis*]. Robust, consisting of 2 main stipes diverging from sicula at less than 180 degrees, bearing lateral branches at irregular intervals which in turn may bear tertiary branches; forms with few or no lateral branches also occur. *L.Ord.* (*Chewton.*), Austral.—FIG. 54,3. **M. mutabilis*; $\times 0.7$ (77).

Trochograptus HOLM, 1881 [**T. diffusus*]. Rhabdosome large, similar to *Schizograptus* but with more widely spaced lateral branches and tertiary branches common. *L.Ord.* (*Arenig.*), NW.Eu.-N.Am.-Austral.—FIG. 54,2. **T. diffusus*, *L. Didymogr.* sh., Oslo; $\times 0.7$ (78).

?**Anthograptus** TÖRNQUIST, 1904 [**A. nidus*]. Proximal end unknown; ?2nd-order stipes of great length, at distal end with lateral branches and stipes of higher order produced by irregular dichotomy. *L.Ord.* (*L. Didymogr. sh.*), S.Swed.—FIG. 54,5. **A. nidus*; $\times 1$ (61).

Section DICHOGRAPTI

With 8 or fewer stipes, dichotomously dividing to 3rd order only; 1st 2 orders generally short, equal in length, 3rd order long and usually flexuous; thecae denticulate, inclined at moderate angles and with considerable overlap, less commonly with low inclination, slight overlap, and (rarely) long apertural spines. *L.Ord.*

Dichograptus SALTER, 1863 [*nom. correct.* HALL, 1865 (*pro Dichograptus* SALTER, 1863) BULMAN, 1955; ICZN pend.] [**Dichograptus sedgwicki*; SD GURLEY, 1896]. Characters of section; central disc in certain species. *L.Ord.* (*Arenig.-Llanv.*), almost world-wide.—FIG. 55, *D. octobrachiatus* (HALL), Levis sh., Que.; $\times 0.5$ (21).

PAUCIRAMOUS FORMS

Pendent, deflexed, declined, horizontal, reflexed, reclined or scandent, wholly or in part; branching dichotomous to 1st or 2nd order only; thecae simple, rarely with sig-

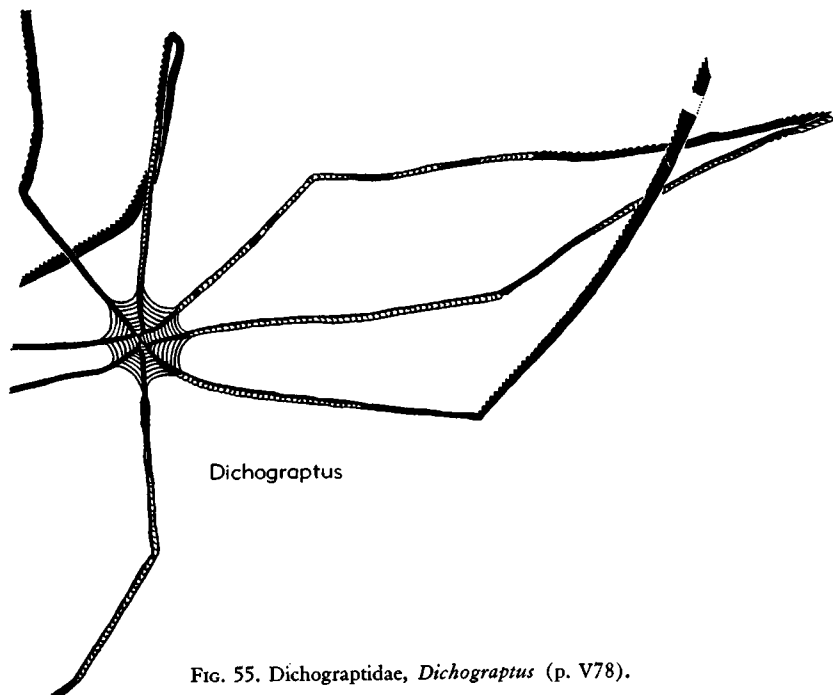

FIG. 55. Dichograptidae, *Dichograptus* (p. V78).

moidal curvature or elaborated apertural modifications. *L.Ord.-M.Ord.*

Section TETRAGRAPTII

Rhabdosome pendent to scandent, composed of 4 stipes of 2nd order; thecae simple, denticulate. *L.Ord.*

Tetragraptus SALTER, 1863 [**Fucoides serra* BRONGNIART, 1828 (= *Graptolithus bryonoides* HALL, 1858)] [= *Graptolithus bryonoides* HALL, 1858)] [= *Etagraptus* RUEDEMANN, 1904; *Eotetragraptus*, *Pendeograptus* BOUČEK & PŘIBYL, 1951]. Bilaterally symmetrical, pendent to reclined; central disc in some horizontal species; funicle usually short, commonly bearing one theca only; development dichograptid or isograptid. *L.Ord.(Arenig.)*, world-wide.—FIG. 56,1a. *T. fruticosus* (HALL), Levis sh., Que.; $\times 1$ (21).—FIG. 56,1b. *T. quadribrachiatus* (HALL), Levis sh., Que.; $\times 1$ (21).—FIG. 56,1c. *T. approximatus* NICHOLSON, *L.Didymogr.* sh., S.Swed.; $\times 1$ (21).—FIG. 56,1d,e. *T. bigsbyi* (HALL), *Orthoceras* ls., Öland, Swed.; 1d,e, lat. and vent. views of specimens dissolved

from limestone, $\times 4$ (27).—FIG. 56,1f,g. *T. phyllograptoides* LINNARSSON, *L.Didymogr.* sh., S.Swed.; $\times 2$ (91). [*Tetragraptus* = *nom. correct.* HALL, 1865 (*pro Tetragraptus* SALTER, 1863) *nom. conserv.* proposed BULMAN, 1955, ICZN pend.]

Phyllograptus HALL, 1858 [**P. typus*]. Quadriserial, composed of 4 scandent 2nd-order stipes; nema unknown; thecae simple, slightly curved, with high inclination and large overlap; development where known isograptid. *L.Ord.(Arenig.-Llanv.)*, world-wide.—FIG. 56,2a. **P. typus*, Levis sh., Que.; $\times 1$ (21).—FIG. 56,2b,c. *P. angustifolius* HALL, *Orthoceras* ls., Öland, Swed.; 2a,b, lat. and vent. views of specimens dissolved from limestone, $\times 4$ (27).

Section DIDYMOGRAPTII

Pendent to scandent, composed of not more than 2 stipes. *L.Ord.-M.Ord.*

Didymograptus M'COY in SEDGWICK & M'COY, 1851 [**Graptolithus murchisoni* BECK, 1839; SD MILLER, 1889] [= *Cladograptus* GEINITZ, 1852; *Atopograptus* HARRIS, 1926; *Expansograptus* BOUČEK &

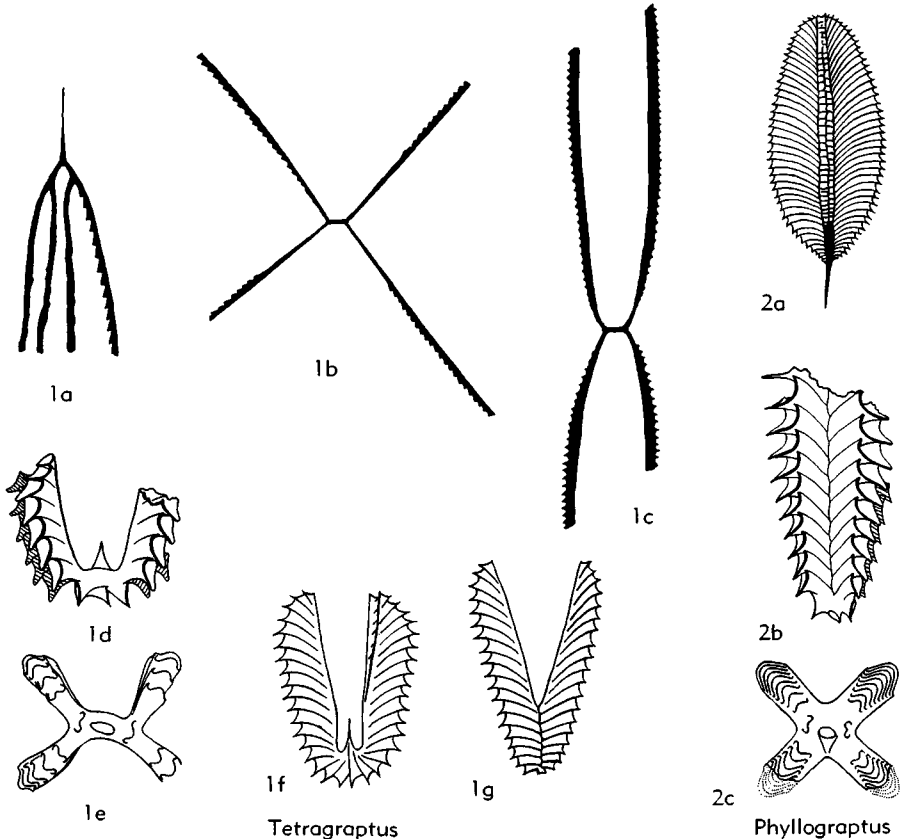

FIG. 56. Dichograptidae, Tetragrapti (p. V79).

PŘIBYL, 1951; *Holmograpthus* KOZŁOWSKI, 1954]. Pendent to reclined; development of dichograptid or isograptid type; thecae typically simple, straight or with slight ventral curvature, rarely sigmoid or with elaborated apertures. *L.Ord.-M.Ord.*; (*Tremadoc.*), Norway-Can.-N.Z.; (*Arenig.-Llanv.*), world-wide; (*Nemagr. gracilis* z.), NW.Eu.-N.Am. —FIG. 57,1a. *D. extensus* (HALL), *L.Ord.*(Levis sh.), Que.; $\times 1$ (21). —FIG. 57,1b. **D. murchisoni* (BECK), *L.Ord.*(Llanv.), S.Wales; $\times 1$ (17). —FIG. 57,1c. *D. nicholsoni* LAPWORTH, *L.Ord.* (Skiddaw sl.), N.Eng.; $\times 1$ (17). —FIG. 57,1d,e. *D. callothea* BULMAN, *L.Ord.*(*Orthoc.* ls.), Öland, Swed.; 1d,e, lat. view and sec. of stipe, $\times 20$ (7). [*Didymograptus* = *nom. correct.* HALL, 1865 (pro *Didymograpsus* M'COY, 1851) *nom. conserv.* proposed BULMAN, 1955, ICZN pend.] *Azygograptus* NICHOLSON & LAPWORTH in NICH., 1875 [**A. lapworthi*] [= *Nicholsonograptus* BOUČEK & PŘIBYL, 1951]. Asymmetrical, unilateral,

composed of a single stipe which may be pendent to reclined. *L.Ord.-M.Ord.*; (*Arenig.-Llanv.*), Eu.-China; (*Normanskill*), N.Am.-S.Am. —FIG. 57,2. *A. succicus* MOBERG, *L.Ord.* (*L.Didymogr.* sh.), S.Swed.; $\times 2$ (85).

Cardiograptus HARRIS & KEBLE, 1916 [**C. morsus*]. Biserial, elongate-ovate, emarginate distally, resembling an *Oncograptus* in which distal uniserial stipes have failed to develop. *L.Ord.*(*U. Yapeen.*), Austral.-China. —FIG. 57,7. **C. morsus*, Vict., Austral.; $\times 1$ (24).

Dinemagraptus KOZŁOWSKI, 1952 [**D. warckae*]. Reclined, each branch reduced to a thread bearing apertural rings without any fusellar periderm; sricula normal. *L.Ord.*(*Arenig.*), Balt. —FIG. 57,9. **D. warckae*, diagrammatic, $\times 4$ (81).

Isograptus MOBERG, 1892 [**Didymograptus gibberulus* NICHOLSON, 1875 (?= *D. caduceus* SALTER, 1853)]. Reclined; thecae elongate with high inclination and large overlap, especially proximally;

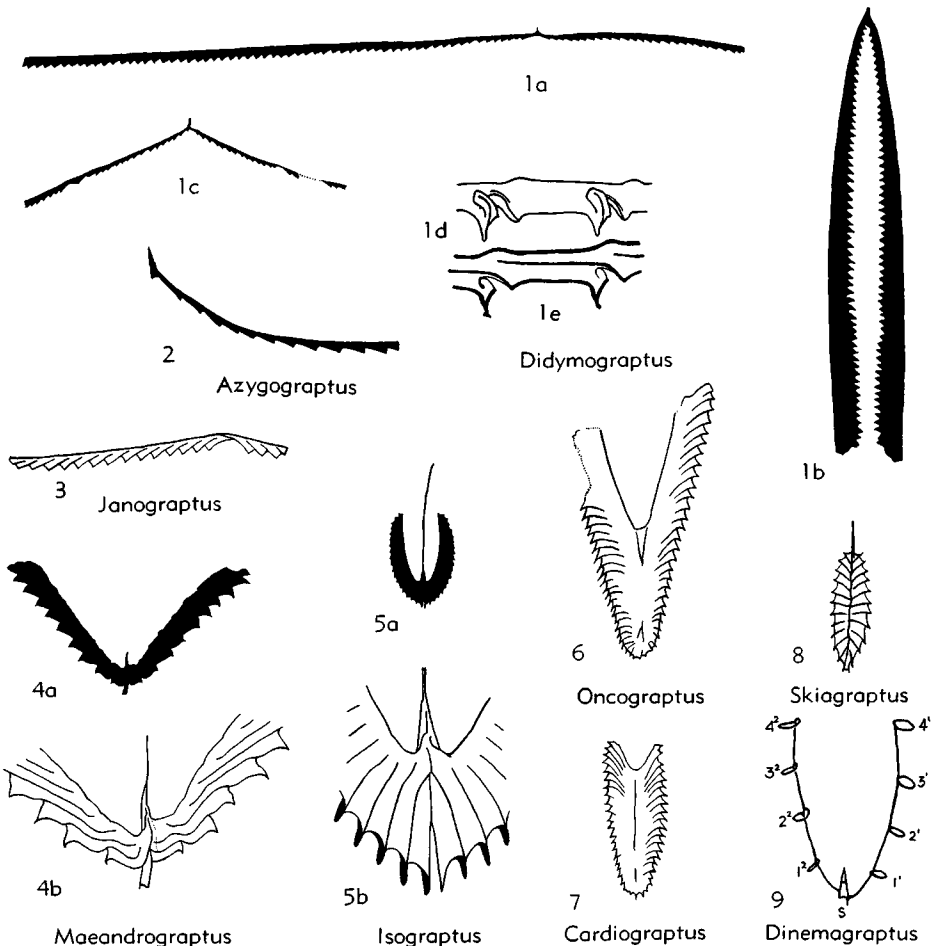

FIG. 57. Dichograptidae, Didymograpti (p. V79-V81).

development isograptid, 1st few thecae growing entirely downward. *L.Ord.*(*Arenig.*), NW.Eu.-N.Am.-S.Am.-Austral.(Castlemain.)-Asia.—FIG. 57,5. **I. gibberulus*, *L.Didymogr.* sh., S.Swed.; 5a, rhabdosome, $\times 1$ (85); 5b, proximal end, $\times 5$ (7).

Janograptus TULLBERG, 1880 [**J. laxatus*]. Resembling an extensiform *Didymograptus* but without apparent sicula; development obscure. *L.Ord.*(*L.Dicellogr.* sh.), Swed.-Norway-S.Am.—FIG. 57,3. **J. laxatus*, S.Swed.; $\times 2$ (92).

Macandrograptus MOBERG, 1892 [**M. schmalenseeii*]. Reclined stipes of uniform width, composed of somewhat undulating elongate thecae with low inclination and large overlap; development of isograptid type, 1st theca of each stipe reclined distally. *L.Ord.*(*L.Didymogr.* sh.), S. Swed.-?Austral.—FIG. 57,4. **M. schmalenseeii*, S.Swed.; 4a, rhabdosome, $\times 2$ (85); 4b, proximal end, $\times 5$ (7).

Oncograptus T.S. HALL, 1914 [**O. upsilon*]. Initially scandent biserial, later diverging; thecae long, slender, with high inclination and considerable overlap; development (where known) of rather primitive dichograptid type, 1st thecae short, downwardly directed, increasing in length distally. *L.Ord.*(*Yapeen.-Arenig.*), Austral.-N.Am.-Ire.—FIG. 57,6. **O. upsilon*, Yapeen., Vict.; $\times 1$ (24).

Parazygograptus KOZŁOWSKI, 1954 [**P. erraticus*]. Like *Azygograptus* but with single stipe based on *th1*² produced from initial bud without metathecal portion of *th1*¹. *L.Ord.*(*Arenig.*), Balt.

Skiagraptus HARRIS, 1933 [**Diplograptus gnomonicus* HARRIS & KEBLE, 1916]. Biserial; thecae short, highly inclined, with large overlap; development apparently dichograptid (?isograptid), proximal thecae growing entirely downward, later thecae horizontal and then distally directed. *L.Ord.*(*Yapeen.*), Austral.—FIG. 57,8. **S. gnomonicus*, Vict.; schematic, $\times 2$ (77).

Family CORYNOIDIDAE Bulman, 1944

[*pro* Corynograptidae HOPKINSON & LAPWORTH, 1875 (ICZN pend.)]

Rhabdosome consisting of very long sicula developing 1 to 3 elongate adnate thecae with 1st one or 2 each bearing a broad lamelliform apertural process like virgella of the sicula, last-formed one being usually rudimentary and its exact nature problematical; initial bud arises high up on prosicula and thecae have alternating origin. *M.Ord.*

Corynoides NICHOLSON, 1867 [**C. calicularis*] [= *Corynograptus* HOPKINSON & LAPWORTH, 1875]. Characters of family. *M.Ord.* (esp. just above *Nemagr. gracilis* z.), NW.Eu.-N.Am.—FIG. 58,1. **C. calicularis*, Ardwell ser., S.Scot.; $\times 13$ (9).—FIG. 58,2. *C. divnoviensis* KOZŁOWSKI, Balt.; $\times 13$ (81).

Family CRYPTOGRAPTIDAE Hadding, 1915

Scandent biserial, with straight stipes in lateral contact so that the common canal of one stipe lies beside thecal apertures of the other; periderm usually much attenuated; development of a modified dichograptid type, with only one crossing canal, 1st 2 thecae (*th1*¹ and *th1*²) growing proximally in contact with sicula for greater part of their length. *L.Ord.-M.Ord.*

Cryptograptus LAPWORTH, 1880 [**Diplograptus tricornis* CARRUTHERS, 1859]. Rhabdosome parallel-sided, with basal spines; thecae inclined at high angle, somewhat climacograptid, with very short free ventral walls, and ringlike apertural lists. *L.Ord.-M.Ord.* almost world-wide.—FIG. 59,1. **C. tricornis*, M.Ord.(Hartfell sh.), S.Scot.; 1a, rhabdosome, $\times 2$ (9); 1b, restoration of proximal part of rhabdosome, ca. $\times 10$ (17).

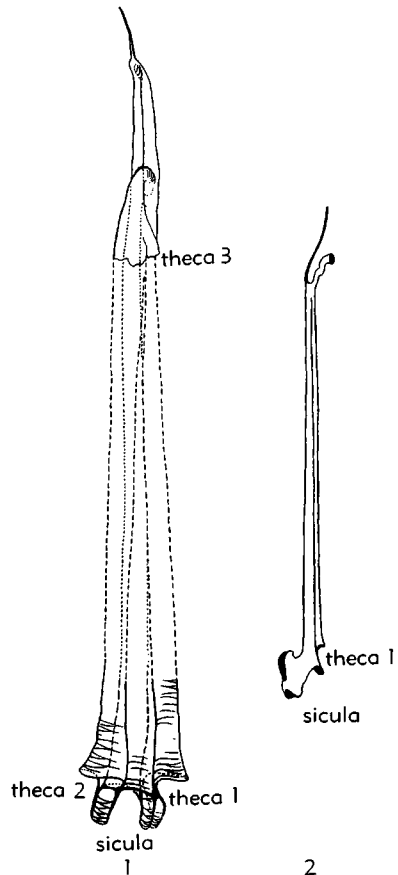

FIG. 58. Corynoididae (p. V81).

Glossograptus EMMONS, 1855 [**G. ciliatus*; SD LAPWORTH, 1873]. Rhabdosome with long apertural spines and still longer dorsal and lateral spines developed in whorls at the level of every 2nd, 3rd, or 4th theca; thecae relatively long, of orthograptid type, with considerable overlap. Development probably as in *Cryptograptus*. *L.Ord.-M.Ord.*, almost world-wide.—FIG. 59,3. *G. hincksi* (HOPKINSON), *M.Ord.*(Glenkiln sh.), S.Scot.; 3*a,b*, biprofile and scalariform views, $\times 2$ (17); 3*c*, restoration of rhabdosome, *ca.* $\times 5$ (72n). [*Glossograptus* = *nom. correct.* HALL, 1865 (*pro Glossograptus* EMMONS, 1855) *nom. conserv.* proposed BULMAN, 1955, ICZN pend.]

Lonchograptus TULLBERG, 1880 [**L. ovatus*]. Like *Glossograptus* but without lateral spines and with dorsal spines represented by single pair of extremely long stout spines. *L.Ord.*, NW.Eu.—FIG. 59,4. **L. ovatus* (*U. Didymogr.* sh.), S.Swed., 4*a*, outline of rhabdosome showing spines, $\times 2$; 4*b*, another specimen showing thecal apertures, $\times 2$ (92).

Nanograptus HADDING, 1915 [**N. lapworthi*; SD BULMAN, 1929]. Rhabdosome minute, not enveloping apical end of rather long sicula; thecae gently curved, bluntly denticulate. *M.Ord.*, NW.Eu.—FIG. 59,2. **N. lapworthi*, *L. Dicellogr.* sh., S.Swed.; 2*a*, rhabdosome, $\times 5$; 2*b*, early growth stage, $\times 5$ (75).

Family LEPTOGRAPTIDAE Lapworth, 1879

Uniserial, bilaterally symmetrical, with 2 slender flexuous stipes having a primary angle of divergence of about 180 degrees; branches (if present) lateral, rarely paired, simple or compound; thecae elongate, typically inclined at low angles and with pronounced sigmoid curvature (leptograptid type); development of leptograptid type. *M.Ord.-U.Ord.*

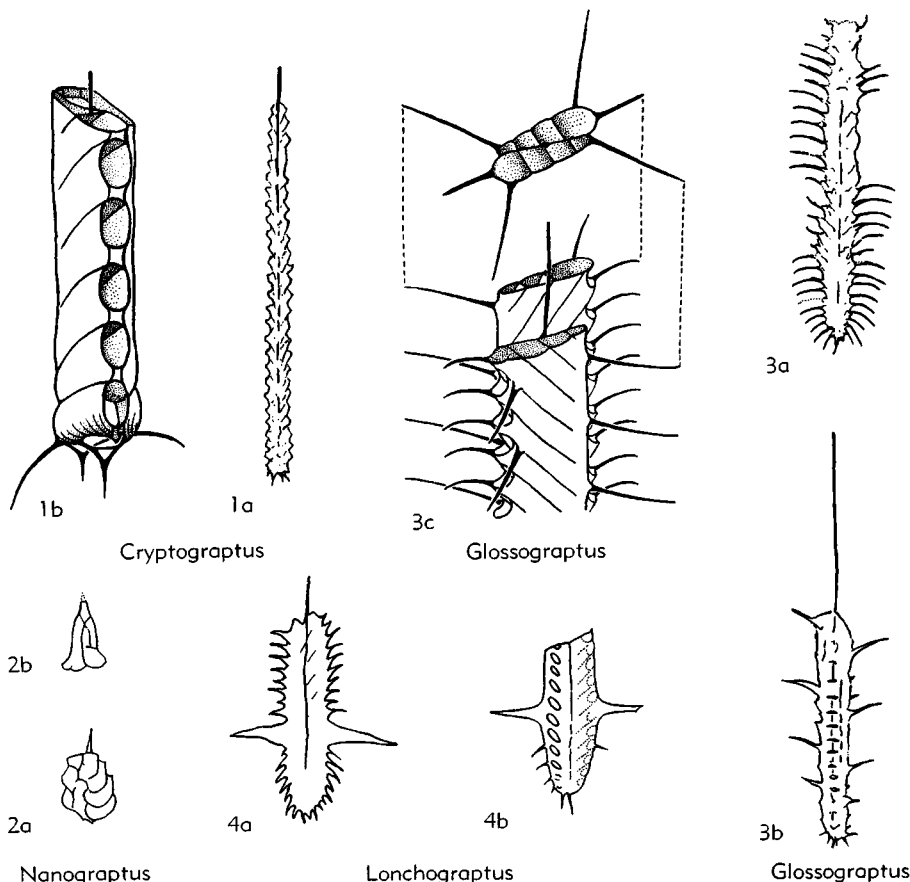

FIG. 59. Cryptograptidae (p. V81-V82).

Leptograptus LAPWORTH, 1873 [**Graptolithus flaccidus* HALL, 1865]. Biramous, stipes, slender, flexuous, slightly reclined, without secondary branches except in centribrachiate mutations. *M.Ord.-U.Ord.* (*Bala-Normanskill-Utica-M.Dicellogr. sh.*), Eu.-N.Am.-Austral.—FIG. 60, *1b,d*.
**L. flaccidus flaccidus* (HALL), *M.Ord.* (Hartfell sh.), S.Scot.; *1b*, centribrachiate form, $\times 1$ (17); *1d*, proximal end, $\times 8$ (72).—FIG. 60, *1a*. *L. flaccidus macilentus* ELLES & WOOD, *M.Ord.* (Hartfell sh.), S.Scot.; $\times 1$ (17).—FIG. 60, *1c*. *L. flaccidus trentonensis* RUEDEMANN, *M.Ord.* (Utica), N.Y.; $\times 3$ (50).

Amphigraptus LAPWORTH, 1873 [**Graptolithus divergens* HALL, 1879] [= *Clematograptus* HOPKINSON, 1875]. Rhabdosome horizontal, composed of 2 straight main stipes with simple or compound, rigid lateral branches, typically produced in pairs. *M.Ord.* (*Normanskill-Hartfell*), Eu.-N.Am.—FIG. 61, *3*. **A. divergens* (HALL); *3a*, rhabdosome from Hartfell sh., S.Scot., $\times 1$ (17); *3b*, proximal end of specimen from Normanskill, N.Y., $\times 3$ (50).

Nemagraptus EMMONS, 1855 [**Graptolithus gracilis* HALL, 1848 (= *Nemagraptus elegans* EMMONS, 1855); SD HALL, 1868] [= *Stephanograptus* GEINITZ, 1866; *Coenograptus* HALL, 1868; *Heliograptus* NICHOLSON, 1868]. Main stipes slender, reclined or more usually curved to form letter S, with regularly produced lateral branches from convex side of each. *M.Ord.* (*Glenkiln-Normanskill*), Eu.-N.Am.-Austral.-Asia.—FIG. 61, *2*. **N. gracilis* (HALL), Glenkiln sh., S.Scot.; $\times 1$ (17). [*Nemagraptus* = *nom. correct.* HALL, 1865 (*pro Nemagraptus* EMMONS, 1855) *nom. conserv.* proposed BULMAN, 1955, ICZN pend.]

Pleurograptus NICHOLSON, 1867 [**Cladograptus linearis* CARRUTHERS, 1858] [= *Cladograptus* CARR., 1858 (*non* EMMONS, 1855)]. Main stipes somewhat flexuous, from one or both sides of which simple or compound branches are given

off rather irregularly. *M.Ord.* (*Hartfell-Utica*), NW.Eu.-N.Am.-?Austral.—FIG. 61, *1*. **P. linearis* (CARR.), Hartfell sh., S.Scot.; $\times 1$ (17). [*Pleurograptus* = *nom. correct.* LAPWORTH, 1873 (*pro Pleurograptus* NICH., 1867) *nom. conserv.* proposed BULMAN, 1955, ICZN pend.]
Syndyograptus RUEDEMANN, 1908 [**S. pecten*]. Like *Amphigraptus* but with reclined main stipes and paired erect branches. *M.Ord.*, N.Am.—FIG. 61, *4*. **S. pecten*, Normanskill, N.Y.; $\times 1$ (50).

Family DICRANOGRAPTIDAE
Lapworth, 1873

Uniserial or uni-biserial, reclined or initially scandent, without branches; thecae with conspicuous sigmoid curvature, some species elaborated; development of leptograptid or diplograptid type. *M.Ord.-U.Ord.*

Dicellograptus HOPKINSON, 1871 [**Didymograptus elegans* CARRUTHERS, 1868; SD GURLEY, 1896]. Rhabdosome of 2 reclined uniserial stipes, straight or curved; development of leptograptid type (*geniculatus* stage). *M.Ord.-U.Ord.* (*Glenkiln-Hartfell-Dicellogr. sh.*), Eu.-N.Am.-Austral.-Asia.—FIG. 62, *1a*. **D. elegans* (CARR.), *M.Ord.* (Hartfell sh.), S.Scot.; $\times 1$ (17).—FIG. 62, *1b*. *D. morrissi*, *M.Ord.* (*Dicellogr. sh.*), Swed.; $\times 4$ (72n). [*Dicellograptus* = *nom. correct.* LAPWORTH, 1873 (*pro Dicellograptus* HOPK., 1871) *nom. conserv.* proposed BULMAN, 1955, ICZN pend.]

Dicranograptus HALL, 1865 [*Cladograptus* EMMONS, 1855 (*non* GEINITZ, 1852)] [**Graptolithus ramosus* HALL, 1848]. Proximally biserial, dividing distally to 2 uniserial reclined stipes; development of diplograptid type (including *dentatus* stage). *M.Ord.* (*Hartfell-Utica*), Eu.-N.Am.-S.Am.-Austral.-Asia.—FIG. 62, *2a*. *D. ramosus longicaulis* ELLES & WOOD, Hartfell sh., S.Scot.; $\times 1$ (17).—FIG. 62, *2b*. *D. nicholsoni* HOPKINSON, Balclatchie, S.Scot.; $\times 4$ (9).

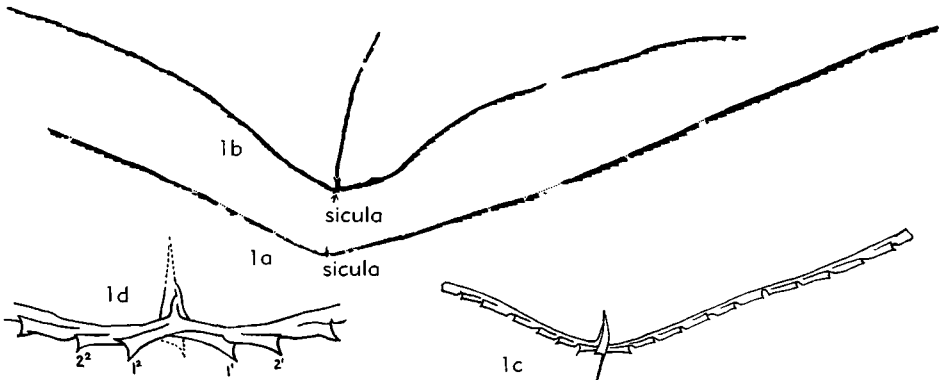

FIG. 60. Leptograptidae, *Leptograptus* (p. V83).

Family DIPLOGRAPTIDAE Lapworth,
1873

Scandent biserial, with straight stipes, adnate dorsally, with or without median septum or with incomplete or partial septum;

thecae straight or with varying degrees of sigmoidal curvature; usually unspined or with apertural or mesial spines restricted to base of rhabdosome, which is oval, circular or rectangular in cross section; periderm

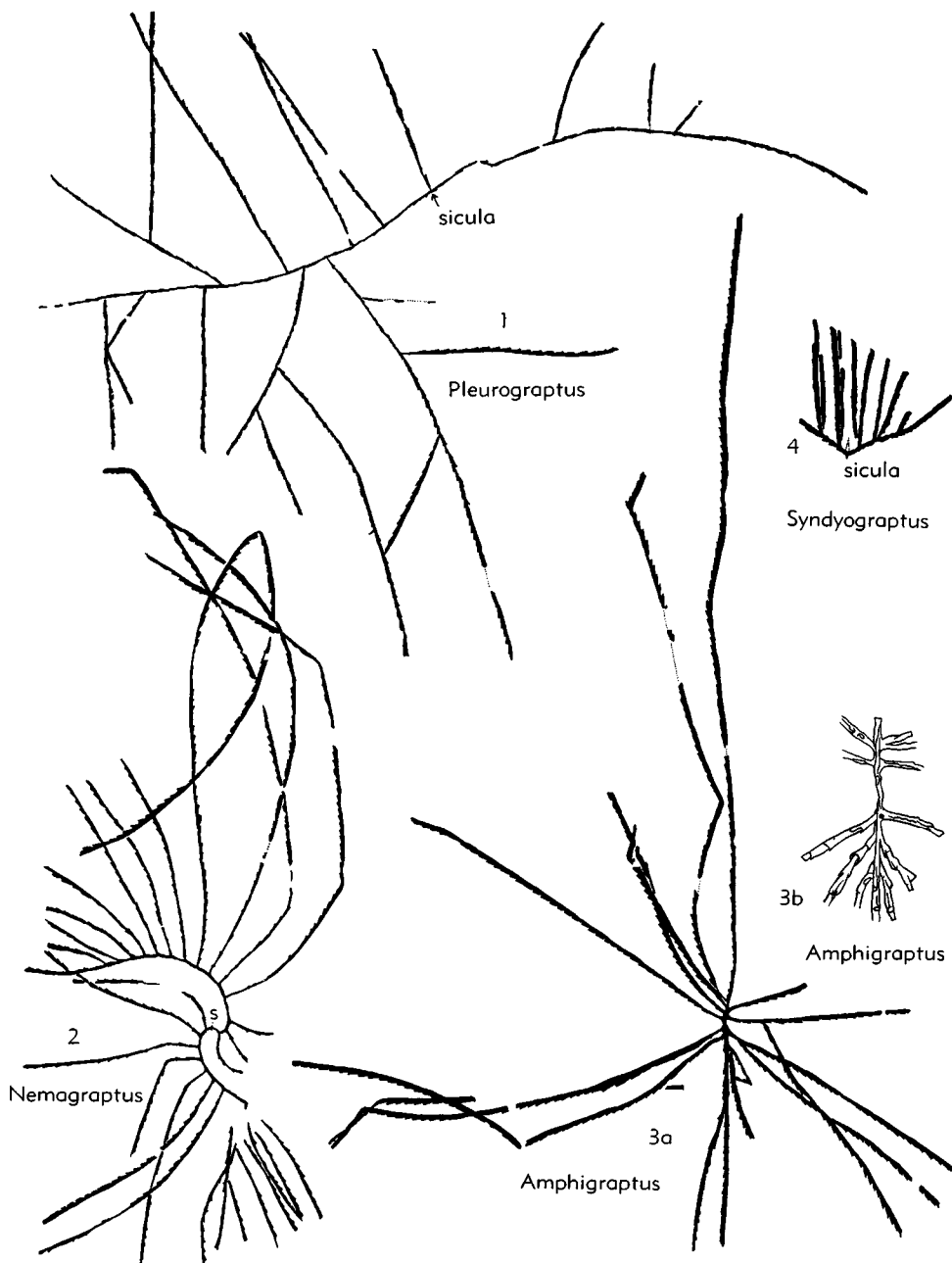

FIG. 61. Leptograptidae (p. V83).

continuous, rarely attenuated or supported by lists; development of diplograptid type. *L.Ord.-L.Sil.*

Subfamily CLIMACOGRAPTINAE Frech, 1897

[*nom. transl.* PŘIBYL, 1948 (*ex* Climacograptidi FRECH, 1897)]

Thecae with angular sigmoidal curvature, part of free ventral wall being parallel to axis of rhabdosome and apertures being situated in narrow excavations; rhabdosome nearly circular in cross section and scalariform views consequently common. *L.Ord.-L.Sil.*

Climacograptus HALL, 1865 [**Graptolithus bicornis* HALL, 1848] [= *Paraclimacograptus* PŘIBYL, 1947; *Pseudoclimacograptus* PŘIBYL, 1948]. Distinction from *Amplexograptus* and *Lasio-graptus* not always easy, especially if apertural excavations are relatively wide or thecae less angularly sigmoidal or bear mesial spines. *L.Ord.-L.Sil.*, world-wide.—FIG. 63,1a. **C. bicornis* (HALL), M.Ord.(Hartfell sh.), S.Scot.; $\times 2$ (17). —FIG. 63,1b. *C. scharenbergi* LAPWORTH, M.Ord.(Balclatchie), S.Scot.; $\times 6$ (9). —FIG. 63,1c. *C. rectangularis* (M'COY), L.Sil.(Birkhill

sh.), S.Scot.; $\times 2$ (17). —FIG. 63,1d. *C. innatus* NICHOLSON, L.Sil.(Birkhill sh.), S.Scot.; $\times 2$ (17).

Subfamily DIPLOGRAPTINAE Lapworth, 1873

[*nom. transl.* PŘIBYL, 1948 (*ex* Diplograptidae LAPWORTH, 1873)]

Thecae straight or with varying degrees of sigmoidal curvature; rhabdosome rectangular or ovoid in cross section. *L.Ord.-L.Sil.*

Diplograptus M'COY, 1850 [**Prionotus pristis* HISINGER, 1837; SD GURLEY, 1896] [= *Mesograptus* ELLES & WOOD, 1907]. Thecae strongly sigmoidal with apertures in broad semicircular excavations (amplexograptid at proximal end, gradually becoming more gently sigmoid (glyptograptid) and almost straight distally; periderm attenuated and with apertural lists proximally; cross section ovoid or nearly rectangular. *M.Ord.-L.Sil.*, Eu.-N.Am.-Austral.-Asia. — FIG. 63,2a. **D. pristis* (His.), U.Ord.(Trinucleus sh.), Swed.; $\times 2$ (92). — FIG. 63,2b. *D. foliaceus* (MURCHISON), M.Ord.(Meadowtown ls.), Eng.; $\times 2$ (72n). [*Diplograptus* = *nom. correct.* HALL, 1865 (*pro* *Diplograpsis* M'COY, 1850) *nom. conserv.* proposed BULMAN, 1955, ICZN pend.]

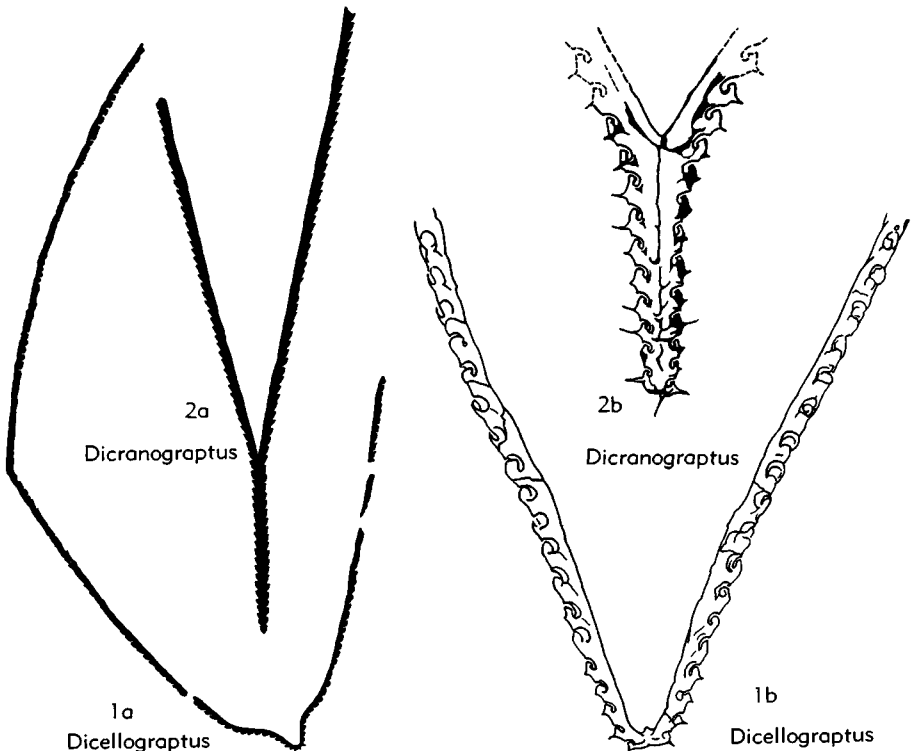

FIG. 62. Dicranograptidae (p. V83).

Amplexograptus ELLES & WOOD, 1907 [*Diplograptus perexcavatus* LAPWORTH, 1876]. Like *Diplograptus* but thecae of amplexograptid type throughout; rhabdosome with attenuated periderm and apertural lists; cross section more or less rectangular. Compression of the attenuated

periderm may produce glyptograptid appearance. *L.Ord.-M.Ord.*, world-wide.—FIG. 63,3. **A. perexcavatus* (LAPWORTH), *M.Ord.*(Glenkiln sh.), S.Scot.; $\times 2$ (17).

Glyptograptus LAPWORTH, 1873 [*Diplograptus tamariscus* NICHOLSON, 1868]. Thecae with gently

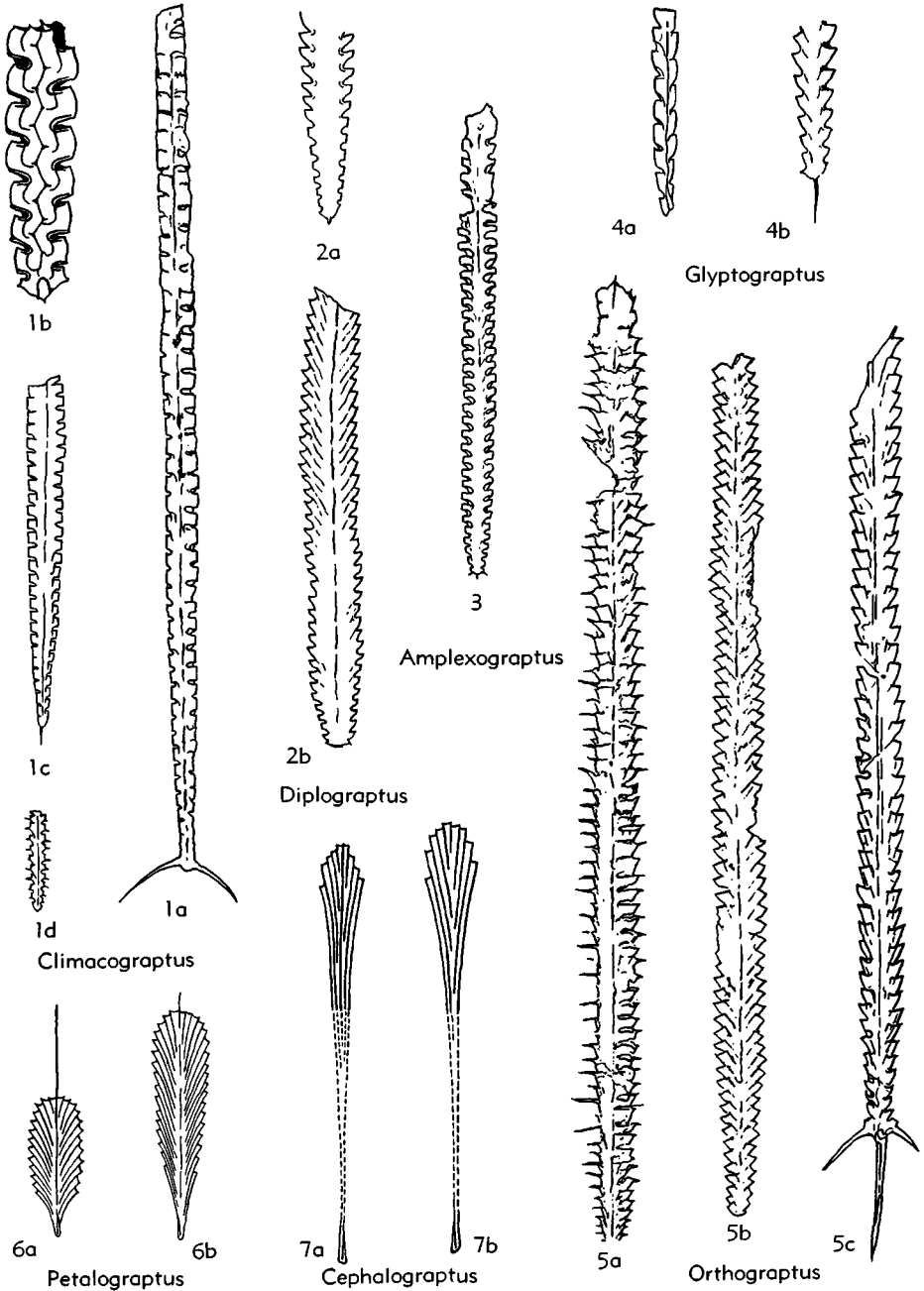

FIG. 63. Diplograptidae (p. V85-V87).

sigmoidal curvature, apertural margins commonly undulate; cross section ovoid or nearly circular. *L.Ord.-L.Sil.*, world-wide.—FIG. 63,4a. **G. tamariscus* (NICH.), *L.Sil.* (Birkhill sh.), S.Scot.; $\times 4$ (17).—FIG. 63,4b. *G. dentatus-teretiusculus* transient, *L.Ord.* (*Orthoceras* ls.), Öland, Swed.; $\times 4$ (7).

Orthograptus LAPWORTH, 1873 [**Graptolithus quadrimucronatus* HALL, 1865] [= *Cystograptus* HUNDT, 1942; *Glossograptus* RUEDEMANN, 1947 *partim* (non EMMONS, 1855); *Rectograptus* PRIBYL, 1949]. Thecae straight or with very slight sigmoid curvature, paired apertural spines in one group, large basal spines not uncommon; rhabdosome rectangular or ovoid in cross section. [*O. quadrimucronatus* and other spined species often have been placed in *Glossograptus* but structure of the rhabdosome and mode of development is that of an undoubted diplograptid.] *M.Ord.-L.Sil.*, world-wide.—FIG. 63,5a. **O. quadrimucronatus* (HALL), *M.Ord.* (Hartfell sh.), S.Scot.; $\times 2$ (17).—FIG. 63,5b. *O. truncatus* (LAPWORTH), *M.Ord.* (Hartfell sh.), S.Scot.; $\times 2$ (17).—FIG. 63,5c. *O. calcaratus* (LAPWORTH), *M.Ord.* (Hartfell sh.), S.Scot.; $\times 2$ (17).

Sufamily PETALOGRAPTINAE Bulman, nov.

Thecae long, nearly straight or with gentle ventral curvature, with large overlap; *th1*¹ and *th1*² with pronounced upward direction of growth, leaving sicula much exposed; rhabdosome tabular, exaggeratedly rectangular in cross section; septum partial or absent. *L.Sil.*

Petalograptus SUESS, 1851 [*pro Diprion* BARRANDE, 1850 and *Petalolithus* SUESS, 1851 (ICZN pend.)] [**Prionotus folium* HISINGER, 1837; SD LAPWORTH, 1873]. Rhabdosome foliate, thecae at a considerable angle to axis of rhabdosome. *L.Sil.*, Eu.-Austral.-China.-N.Afr.-?N.Am.—FIG. 63,6, **P. folium* (HIS.), *Rastrites* sh., S. Swed.; 6a,b, obverse and reverse views, $\times 2$ (92).

Cephalograptus HOPKINSON, 1869 [**Diplograptus cometa* GEINITZ, 1852]. An extreme development of *Petalograptus*; rhabdosome more or less triangular, composed of few elongate thecae. *L.Sil.*, Eu.-China.—FIG. 63,7. **C. cometa* (GEINITZ), *Rastrites* sh., S.Swed.; 7a,b, obverse and reverse views, $\times 2$ (59). [*Cephalograptus* = *nom. correct.* LAPWORTH, 1873 (*pro Cephalograptus* HOPKINSON, 1869) *nom. conserv.* proposed BULMAN, 1955, ICZN pend.]

Family ?Diplograptidae Incertae Sedis

Trigonograptus NICHOLSON, 1869 [**T. lanceolatus*]. Rhabdosome fusiform, concavo-convex or trigonal in cross section, thecae markedly alternating, almost straight, overlapping for their entire length, apertural margins forming an even line. Development unknown. *L.Ord.*, Eu.-N.Am.-Austral.—FIG. 64,1. *T. ensiformis* (HALL), Skiddaw sl.,

N.Eng.; $\times 2$ (17). [*Trigonograptus* = *nom. correct.* LAPWORTH, 1873 (*pro Trigonograptus* NICH., 1869) *nom. conserv.* proposed BULMAN, 1955, ICZN pend.]

Gymnograptus BULMAN, 1953 (*ex TULLBERG MS*) [**Diplograptus linnarssoni*! MOBERG, 1896 (*ex TULLBERG MS*)] [?= *Idiograptus* LAPWORTH, 1880]. Rhabdosome somewhat flattened and more or less tabular in cross section, with well-developed parietal lists and zigzag median list on both sides; thecae straight, orthograptid, highly inclined to axis and provided with long apertural spines; development diplograptid. *L.Ord.*, NW.Eu.—FIG. 64,2. **G. linnarssoni* (MOBERG), *Ogygiocaris* ser., Norway; $\times 3$ (72).

Peiragraptus STRACHAN, 1954 [**P. fallax*]. Rhabdosome uniserial except for presence of *th1*²; development of incomplete diplograptid type. *U.Ord.*, Can.

Family LASIOGRAPTIDAE Bulman, nov.

Scandent biserial rhabdosomes, with attenuated periderm, more or less well-developed clathria, and conspicuous development of thecal and septal spines, usually with lacinia. Thecae of orthograptid or amplexograptid type; development, where known, of diplograptid type. *Ord.*

Lasiograptus LAPWORTH, 1873 [**L. costatus*] [= *Thysanograptus* ELLES & WOOD, 1908]. Thecae of amplexograptid type; clathria especially of pleural and apertural lists, periderm attenuated; conspicuous apertural and mesial spines, commonly forming lacinia distally. *Ord.* (*U. Arenig-Bala*), Eu.-

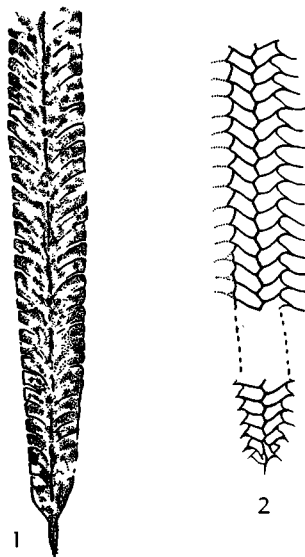

Trigonograptus Gymnograptus

FIG. 64. ?Diplograptidae (p. V87).

S.Am.-?N.Am.-Austral.—FIG. 65,2a,b. *L. hystrix* BULMAN, L.Ord.(*Orthoceras* ls.), S.Swed.; 2a, rhabdosome, $\times 6$; 2b, proximal end, $\times 14$ (?).—FIG. 65,2c. **L. costatus*, M.Ord.(Hartfell sh.), S.Scot.; $\times 2$ (17).

Hallograptus LAPWORTH, 1877 (ex CARRUTHERS MS) [**Graptolithus mucronatus* HALL, 1847; SD ELLES & WOOD, 1908]. Thecae of orthograptid type, with long, apparently paired, apertural spines; clathria weakly developed, lacinia absent; septal processes (scopulae) visible in scalariform view. Ord.(*Arenig-L.Bala*), Eu.-N.Am.—FIG. 65,1a. **H. mucronatus bimucronatus* (NICH.), M. Ord. (Glenkiln sh.), S. Scot.; $\times 2$ (17).—FIG. 65,1b. **H. mucronatus mucronatus* (HALL), Glenkiln sh., S.Scot.; $\times 2$ (17).

Neurograptus ELLES & WOOD, 1908 [=LAPWORTH, 1875 (nom. nud.)] [**Lasiograptus margaritatus* LAPWORTH, 1876; SD BULMAN, 1929]. Thecae as in *Hallograptus*; apertural spines breaking up distally into a highly developed lacinia; scopulate septal processes also well developed. M.Ord., Eu.-N.Am.-Austral.—FIG. 65,3. **N. margaritatus* (LAPWORTH), M.Ord.(Hartfell sh.), S.Scot.; $\times 2$ (17).

Nymphograptus ELLES & WOOD, 1908 (ex LAPWORTH MS) [**N. velatus*]. Thecae apparently as in *Hallograptus*; septal strands very strongly developed to form elaborate lacinia enveloping rhabdosome. U.Ord., Eu.-Austral.—FIG. 65,4. **N. velatus*, Hartfell sh., S.Scot.; $\times 2$ (17).

Family RETIOLITIDAE Lapworth, 1873

Scandent biserial, with straight stipes,

adnate dorsally; periderm reduced to mesh-work composed of reticula or clathria or both, lacinia present in some forms. Thecae markedly alternate. M.Ord.-U.Sil.

This undoubtedly is a polyphyletic assemblage which may for convenience be provisionally divided into the following groups.

Subfamily ARCHIRETIOLITINAE Bulman, nov.

Sicula to some extent chitinized; development of diplograptid type. M.Ord.-U.Ord.

Archiretiolites EISENACK, 1935 [**A. regimontanus*]. Reticula well developed; sicula alone fully chitinized. U.Ord., NW.Eu.—FIG. 66,2. **A. regimontanus*, U.Ord., Balt.; $\times 8$ (74).

Orthoretiolites WHITTINGTON, 1954 [**O. hami*]. Clathria only, with unpaired apertural spines; sicula and proximal parts of *th1*¹ and *th1*² chitinized. M.Ord., N.Am.—FIG. 66,1. **O. hami*, Okla.; $\times 8$ (95).

Plegmatograptus ELLES & WOOD, 1908 [**P. nebula*; SD BULMAN, 1929]. Reticula with well-developed lacinia; ?membranous periderm and chitinized sicula. Development unknown. M.Ord., NW.Eu.-?N.Am.-Austral.—FIG. 66,4. **P. nebula*, Hartfell sh., S.Scot.; $\times 2$ (17).

Retiograptus HALL, 1859 [**R. geinitzianus*] [=Clathrograptus LAPWORTH, 1873]. Clathria only, supporting a membranous periderm at proximal end of rhabdosome; sicula ?chitinized. M.Ord., Eu.-N.Am.-China.—FIG. 66,3. **R. geinitzianus*, Normanskill, N.Y.; $\times 4$ (50).

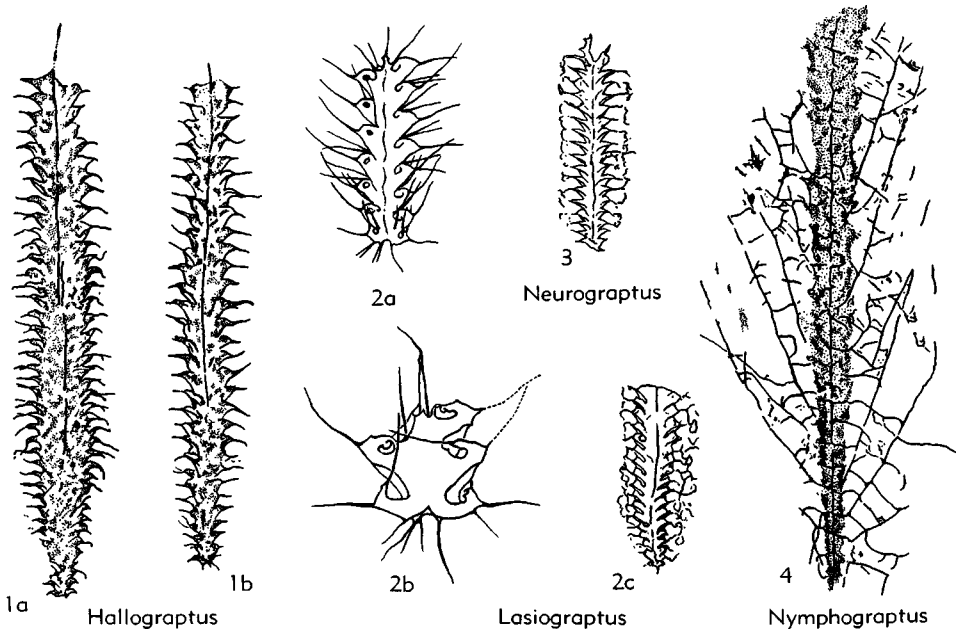

FIG. 65. Lasiograptidae (p. V87-V88).

Subfamily RETIOLITINAE Lapworth, 1873

[*nom. transl.* BOUČEK & MÜNCH, 1952 (*ex* Retiolitidae LAPWORTH, 1873)]

Well-developed reticula supported on a distinct clathria, sicula unchitinized or par-

tially chitinized (prosicula); development with partially developed ancora stage. *L.Sil.*

Retiolites BARRANDE, 1850 [*nom. conserv.* (ICZN Opinion 199)] [**Gladiolites geinitzianus*] [= *Gladiolites* BARRANDE, 1850; *Gladigraptus* LAP-

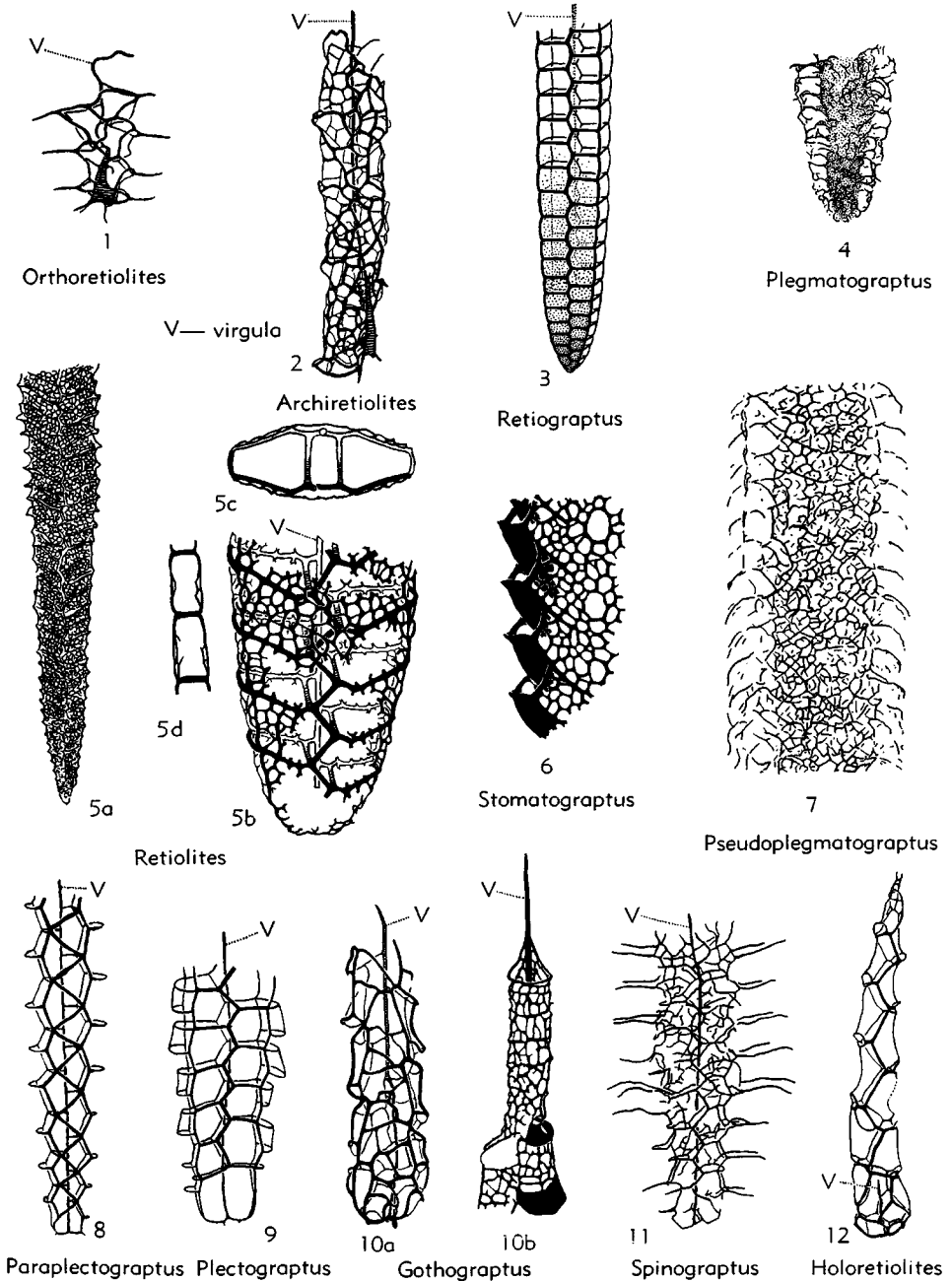

FIG. 66. Retiolitidae (p. V88-V90).

WORTH, 1875; *Dimyktograptus* HABERFELNER, 1936; *Pseudoretiolites* BOUČEK & MÜNCH, 1944]. Reticula on strongly developed clathria of parietal, pleural, apertural and aboral lists, with virgula rapidly incorporated on one side and dorsal list ("zigzag virgula") on other. *L.Sil.-M.Sil.*, Eu.-N.Am.-N.Afr.-? Austral.—FIG. 66,5. **R. geinitzianus*, 5a, rhabdosome from *L.Sil.*, Bohemia, $\times 2$ (4); 5b-d, structural details of specimen from *L.Sil.*, Dalarne, Swed., $\times 12$ (26).

Pseudoplegmatograptus PŘIBYL, 1948 [**Retiolites perlatus obesus* LAPWORTH, 1877]. Like *Retiolites* but with somewhat ill-defined clathria and well-developed lacinia. *L.Sil.*, Eu.—FIG. 66,7. **P. obesus* (LAPWORTH), Gala, S.Scot.; $\times 4$ (17).

Stomatograptus TULLBERG, 1883 [**S. törnquisti* (= *Retiolites grandis* SUESS, 1851)]. Like *Retiolites* but with solid interthecal septa, less overlapping thecae, and median row of large pores in reticula. *L.Sil.-M.Sil.*, Eu.-Austral.—FIG. 66,6. **S. grandis* (SUESS), *L.Sil.*, Dalarne, Swed., $\times 12$ (26).

Subfamily PLECTOGRAPTINAE Bouček & Münch, 1952

Clathria well developed, commonly without reticula, lacinia absent; development with ancora stage; proximal end of rhabdosome usually somewhat inflated (corona), narrowing distally and in some genera terminating in a slender tubular "appendix." *M.Sil.-U.Sil.*, ?*L.Sil.*

Plectograptus MOBERG & TÖRNQUIST, 1909 [**Retiolites macilentus* TÖRNQUIST, 1887]. Rhabdosome rectangular in cross section, composed of open, subhexagonal meshes (clathria) with subordinate reticula, open distally, with central (free) virgula. *M.Sil.-U.Sil.*, Eu.—FIG. 66,9. **P. macilentus* (TÖRNQUIST), *L.Ludlow*, Bohemia; proximal portion of rhabdosome, $\times 4$ (4).

Gothograptus FRECH, 1897 [**Retiolites nassa* HOLM, 1890]. More or less circular in cross section, thecal apertures connected by ventral instead of pleural lists, reticula usually fairly well developed; rhabdosome tapering distally and terminating in tubular appendix; virgula central in the corona, later incorporated in lateral wall. *U.Sil.*, Eu.—FIG. 66,10b. **G. nassa* (HOLM), Balt.; $\times 12$ (67). —FIG. 66,10a. *G. intermedius* BOUČEK & MÜNCH, Balt.; $\times 12$ (67).

Holoretiolites EISENACK, 1951 [**Retiolites mančki* MÜNCH, 1931] [= *Balticograptus* BOUČEK & MÜNCH, 1952]. Tapering rhabdosome with inflated corona, usually with distal appendix, composed of clathria only; thecae climacograptid, their apertures connected by ventral lists; virgula central, confined to proximal end (corona). *U.Sil.*, Eu.—FIG. 66,12. **H. mančki* (MÜNCH), Balt.; $\times 10$ (67).

Paraplectograptus BOUČEK & MÜNCH, 1948 [**Retiolites eiseli* MANCK, 1917]. More or less square in cross section, with virgula embedded in one wall and pleural lists arranged in zigzag line in other; reticula subordinate or absent. ?*L.Sil.*, *M.Sil.*, Eu.-? Austral.—FIG. 66,8. **R. eiseli* (MANCK), *M.Sil.*, Bohemia; $\times 4$ (4).

Spinograptus BOUČEK & MÜNCH, 1952 [**Retiolites spinosus* WOOD, 1900]. Like *Plectograptus* but with better-developed reticula and paired apertural spines. *U.Sil.*, Eu.—FIG. 66,11. **S. spinosus* (WOOD), *L.Ludlow*, Bohemia; $\times 4$ (4).

Family DIMORPHOGRAPTIDAE Elles & Wood, 1908

Proximal portion of rhabdosome uniserial with loss of *th1*² and generally further thecae of the secondary series, becoming biserial distally; biserial portion usually with partial septum; development more or less of monograptid type. *L.Sil.*

Dimorphograptus LAPWORTH, 1876 [**D. elongatus*; SD BASSLER, 1915] [= *Bulmanograptus* PŘIBYL, 1948]. Thecae of orthograptid or glyptograptid

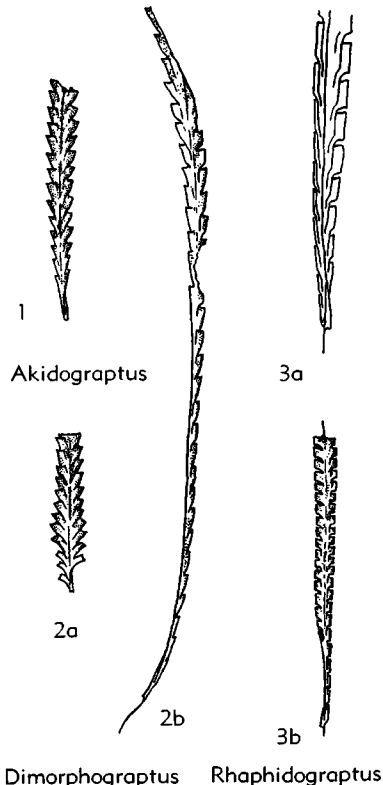

FIG. 67. Dimorphograptidae (p. V90-V91).

type with a tendency in some species toward isolation of apertural region; uniseriate portion of varying length; development monograptid with initial bud upwardly directed at origin. *L.Sil.*, Eu.—China. —FIG. 67,2a. *D. decussatus* ELLES & WOOD, Birkhill sh., S.Scot.; $\times 2$ (17). —FIG. 67,2b. **D. elongatus*, Birkhill sh., S.Scot.; $\times 2$ (17).

Akidograptus DAVIES, 1929 [**A. ascensus*]. Thecae climacograptid or orthograptid; proximal end characterized by loss or reduction of $th1^2$; but owing to the shortening of $th2^2$ there is no appar-

ent uniseriate portion; initial bud downwardly directed at origin. *L.Sil.*, Eu.—?China. —FIG. 67,1. *A. acuminatus* (NICHOLSON), L.Birkhill sh., S.Scot.; $\times 2$ (17).

Rhaphidograptus BULMAN, 1936 [**Climacograptus törnquisti* ELLES & WOOD, 1906] [= *Metadimorphograptus* PŘIBYL, 1948]. Like *Dimorphograptus* but with thecae of climacograptid type; initial bud downwardly or upwardly directed at origin. *L.Sil.*, Eu. —FIG. 67,3a. **R. törnquisti* (ELLES & WOOD), Wales; $\times 3$ (72). —FIG. 67,3b. *R. extenuatus* (ELLES & WOOD), Birkhill sh., S.Scot.; $\times 2$ (17).

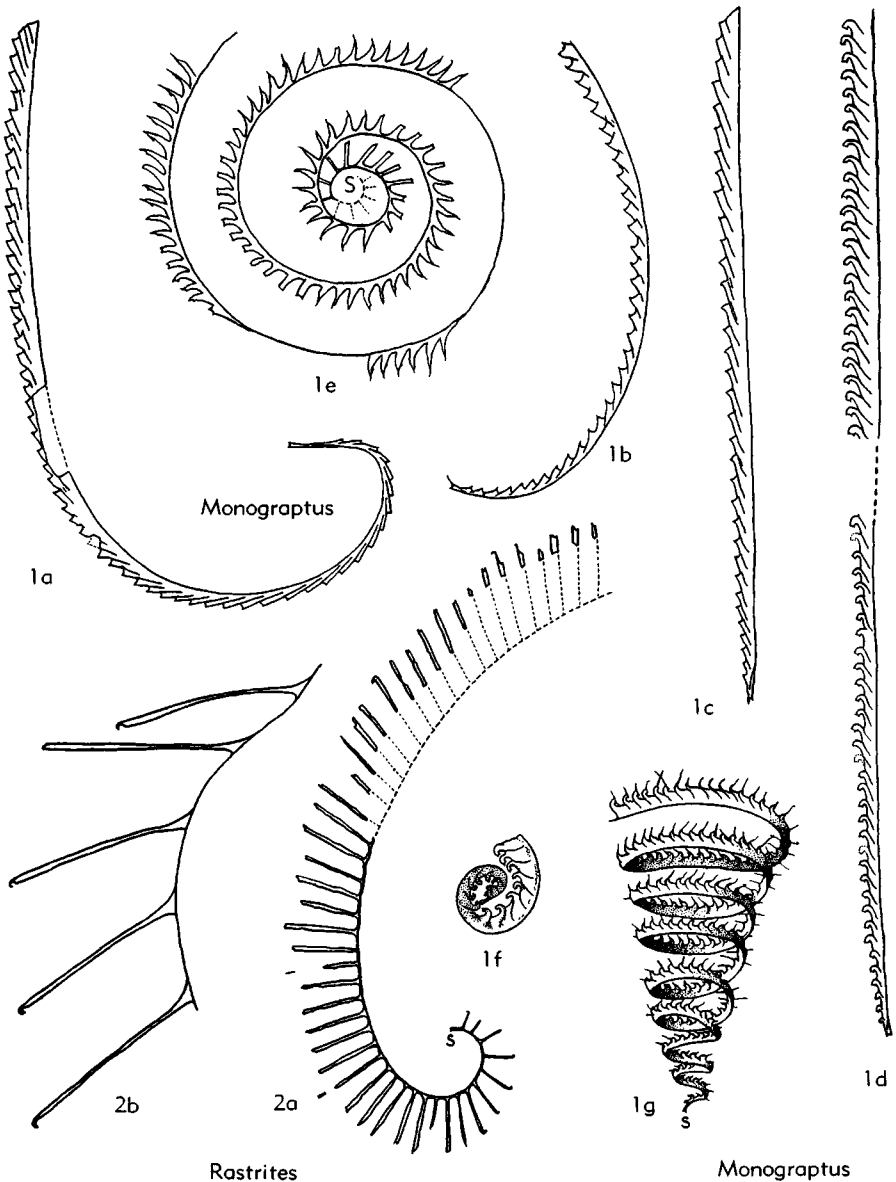

FIG. 68. Monograptidae, Monograptinae (p. V92-V93).

Family MONOGRAPTIDAE Lapworth, 1873

Scandent uniserial rhabdosomes, straight or curved, simple or compound (with cladia); thecae very variable in form; development of monograptid type, first theca growing upward from its origin. *Sil.*

Subfamily MONOGRAPTINAE Lapworth, 1873

[*nom. transl.* YIN, 1937 (*ex Monograptidae LAPWORTH, 1873*)]
 Rhabdosomes simple. *L.Sil.-U.Sil.*

Monograptus GEINITZ, 1852 [*pro Lomatoceras* BRONN, 1835 (*etiam Monoprion* BARRANDE, 1850) (ICZN Opinion 198)] [**Lomatoceras priodon* BRONN, 1835; SD BASSLER, 1915] [= *Pomatograptus* JAEKEL, 1889] [Following names, proposed mostly for assemblages classed as subgenera, are considered to be technically valid but here are included as synonyms (see p. V69): *Pristiograptus* JAEKEL, 1889 (**P. frequens*); *Monoclimacis* FRECH, 1897 (**Graptolites vomerinus* NICHOLSON, 1872); *Spirograptus* GÜRICH, 1908 (**Graptolithus turriculatus* BARRANDE, 1850;

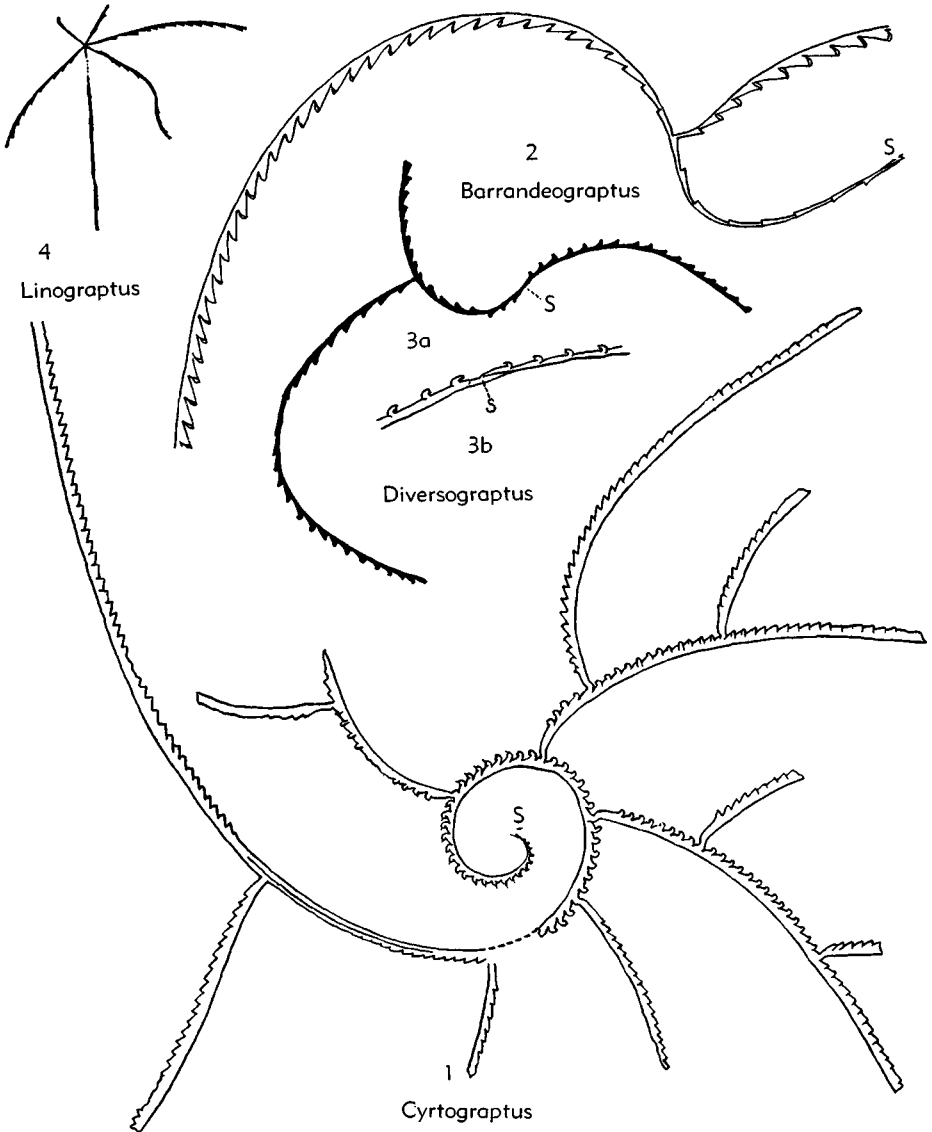

FIG. 69. Monograptidae, Cyrtograptinae (p. V93-V94).

SD BULMAN, 1929); *Demirastrites* EISEL, 1912 (**Rastrites triangulatus* HARKNESS, 1951; SD BULMAN, 1929); *Sireptograptus* YIN, 1937 (**Monograptus nodifer* TÖRNQUIST, 1881); *Colonograptus* PŘIBYL, 1942 (**Graptolithus colonus* BARRANDE, 1850); *Pernerograptus* PŘIBYL, 1941 (**Graptolites argenteus* NICH., 1872); *Saetograptus* PŘIBYL, 1942 (**Graptolithus chimaera* BARRANDE, 1850); *Globosograptus* BOUČEK & PŘIBYL, 1948 (**Monograptus wimani* BOUČEK, 1932); *Mediograptus* BOUČEK & PŘIBYL, 1948 (**Monograptus olihai* BOUČEK, 1932); *Cucullograptus* URBANEK, 1954 (**C. pazdroi*]). Thecae highly variable, straight (dichograptid), curved (glyptograptid or climacograptid), or distally isolate (hooked, lobate, triangulate); in many species with at least 2 thecal types in same rhabdosome, one proximally and other distally (biform monograptids). *Sil.*, world-wide.—FIG. 68,1a. *M. cyphus* LAPWORTH, L.Sil.(L. Birkhill sh.), S.Scot.; $\times 2$ (17).—FIG. 68,1b. *M. bohemicus* (BARRANDE), U.Sil.(L.Ludlow sh.), Wales; $\times 2$ (17).—FIG. 68,1c. *M. dubius* (Suess), U.Sil.(L.Ludlow sh.), Eng.; $\times 2$ (17).—FIG. 68,1d. **M. priodon* (BRONN), L.Sil.(Gala), S.Scot.; proximal and distal ends of long rhabdosome, $\times 2$ (17).—FIG. 68,1e. *M. convolutus* (HISINGER), L.Sil.(*Rastrites* sh.), S.Swed.; $\times 2$ (60).—FIG. 68,1f. *M. discus* TÖRNQUIST, L.Sil.(Tarannon), Wales; $\times 4$ (17).—FIG. 68,1g. *M. turriculatus* (BARRANDE), L.Sil., Bohemia; $\times 2$ (1).

Rastrites BARRANDE, 1850 [**R. peregrinus*; SD MILLER, 1889] [= *Rastrograptus* HOPKINSON & LAPWORTH, 1875]. Rhabdosome curved or hook-

shaped, common canal threadlike, thecae widely spaced, straight, isolated, with tiny hooked apertures, extending from common canal at high angles. *L.Sil.*(mid. and up.parts), Eu.-N.Afr.-Asia-?Austral.-Greenl.—FIG. 68,2a. *R. longispinus* (PERNER), Birkhill sh., S.Scot.; $\times 2$ (17).—FIG. 68,2b. *R. maximus* CARRUTHERS, U.Birkhill sh., S.Scot.; $\times 2$ (17).

Subfamily CYRTOGRAPTINAE Bouček, 1933

[*nom. transl.* YIN, 1937 (*ex* Cyrtograptidae Bouček, 1933)]

Rhabdosomes compound. *L.Sil.*-*U.Sil.*

Cyrtograptus CARRUTHERS, 1867 [**C. purchisoni*] [= *Lapworthograptus* BOUČEK & PŘIBYL, 1952]. Rhabdosome more or less spirally coiled, helicoidally at proximal end, with cladia developed on main stipe (primary cladia) (p. V65) and in many species on cladia themselves (2nd and higher orders); thecae biform, proximally triangulate with lateral apertural spines, becoming simpler distally. *M.Sil.*, Eu.-N.Am.-N.Afr.-Asia.—FIG. 69,1. **C. purchisoni*, Bohemia; $\times 2$ (3). [*Cyrtograptus* = *nom. correct.* LAPWORTH, 1873 (*pro* *Cyrtograptus* CARR., 1867) *nom. conserv.* proposed BULMAN, 1955, ICZN pend.]

Abiesgraptus HUNDT, 1935 [**A. multiramosus*; SD BULMAN, 1938] [= *Gangliograptus* HUNDT, 1939]. Rhabdosome compound, ?bilateral, with numerous paired secondary "branches" (?cladia) diverging at high angles from a straight main stipe; thecae simple. *U.Sil.*(Ludlow), Ger.—FIG. 70. **A. multiramosus*; $\times 0.7$ (80).

Barrandeograptus BOUČEK, 1933 [**Cyrtograptus pulchellus* TULLBERG, 1883]. Rhabdosome slender;

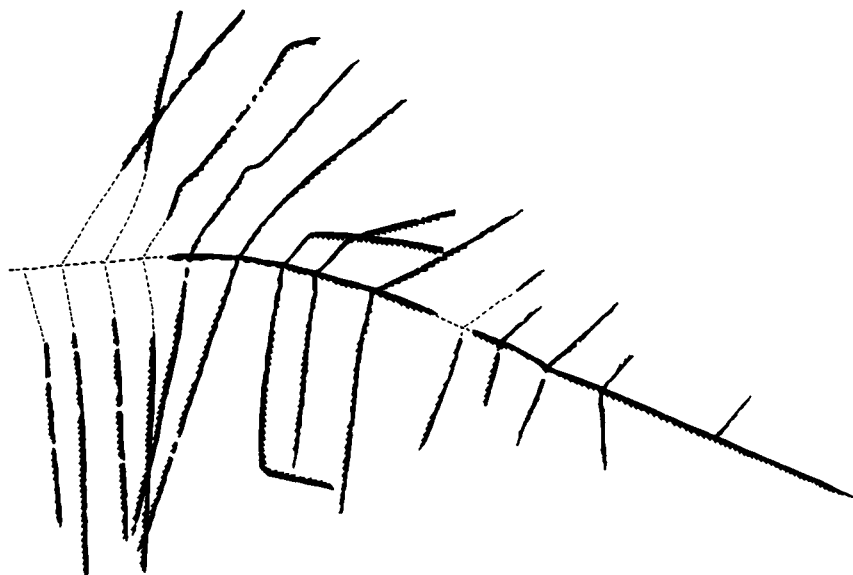

FIG. 70. Monograptidae, *Abiesgraptus* (p. V93).

thecae without apertural spines, simple in form throughout, or at most with very slight hook in proximal thecae. *M.Sil.*, Eu.-?N.Am.—FIG. 69,2. **B. pulchellus* (TULLBERG), S.Swed.; $\times 2$ (62). *Diversograptus* MANCK, 1923 [**D. ramosus*; SD BULMAN, 1929]. Rhabdosome bilateral, with one cladium developed from the sicula, with or without cladia on main stipe and this secondary stipe; stipes usually slender, thecae more or less lobate, *L.Sil.*, Eu.-?N.Am.—FIG. 69,3a. **D. ramosus*,

Ger.; $\times 2$ (84).—FIG. 69,3b. *D. runcinatus* (LAPWORTH), Gala, S.Scot.; $\times 4$ (90).

Linograptus FRECH, 1897 [**Dicranograptus posthumus* RICHTER, 1875 (= *Linograptus nilssoni* FRECH, 1897; non *Graptolithus nilssoni* BARRANDE, 1850)]. Rhabdosome compound, consisting of 3 to 6 or more uniserial simple stipes radiating from a common point of origin (?sicular cladia). *U.Sil.* (Ludlow), Eu.-N.Am.-Austral.—FIG. 69,4. **L. posthumus* (RICHTER), Silesia; $\times 3$ (73).

GRAPTOLITHINA INCERTAE SEDIS

Group GRAPTOVERMIDA Kozłowski, 1949

Small irregularly coiled chitinous tubes with fusellar structure. *Ord.*

Graptovermis KOZŁOWSKI, 1949 [**G. spiralis*]. Flexuous or irregularly coiled chitinous tubes with a diameter of 100 to 400 microns, attached by one surface; growth by addition of fusellar segments as in Graptolithina. *L.Ord.*(*Tremadoc.*), Pol.

?*Melanostrophus* ÖPİK, 1930 [**M. fokini*]. Long, irregularly bent and coiled tubes in confused associations; presence of growth lines demonstrated by EISENACK. *Ord.*(*B₃*, *C₁*, *C₂*, *D₁*), Balt.

Group GRAPTOBLASTI Kozłowski, 1949

Small, ovoid chitinous bodies attached by the lower surface, upper surface with 2 series of transverse ridges meeting in a longitudinal zigzag crest; spaces between ridges appear to correspond to fusellar segments of Graptolithina. So-called anterior end provided with a spine (filium), posterior

with a rounded protuberance called ombilic, which may contain a circular pore (cryptostyle). The vesicle may be undivided or be divided into 2 chambers by a complete transverse partition (Fig. 71). Anterior chamber (usually smaller) is completely sealed off, posterior one may communicate with exterior by cryptopyle. *L.Ord.*(*Tremadoc.*).

Graptoblastus KOZŁOWSKI, 1949 [**G. planus*]. Divided by transverse partition into anterior and posterior chambers. *Tremadoc.*, Pol.—FIG. 71. **G. planus*; reconstr., $\times 40$ (32).

Graptoblastoides KOZŁOWSKI, 1949 [**G. nowaki*]. Without transverse partition. *Tremadoc.*, Pol.

Group ACANTHASTIDA Kozłowski, 1949

Small chitinous bodies with somewhat complicated structure which appear to represent secretion of sessile colonial organism of an unknown nature. Colony discoidal, 4 to 5 mm. in diameter, attached by flattened lower surface; upper surface convex, composed of central perforated area (reticulum) bearing a few large spines surrounded by a ring of long spines; these together with the subreticular cavity constitute the spinarium. Around the spinarium lies a peripheral region with an irregularly rugose or even spinose surface, called calotte (Fig. 72). A number of radially arranged chambers underlie the calotte and spinarium; these do not communicate with one another or with the exterior but their upper portion extends into adjacent trabeculae of the reticulum. *L.Ord.*(*Tremadoc.*).

Acanthastus KOZŁOWSKI, 1949 [**A. luniewski*]. *Tremadoc.*, Pol.—FIG. 72. **A. luniewski*; reconstr., $\times 15$ (32).

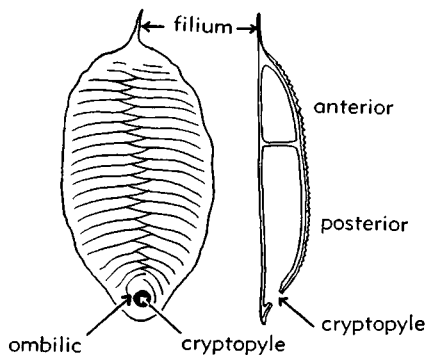

FIG. 71. Restoration of *Graptoblastus* in dorsal view showing transverse ridges and median crest, and in median section showing anterior and posterior chambers, ca. $\times 40$ (32).

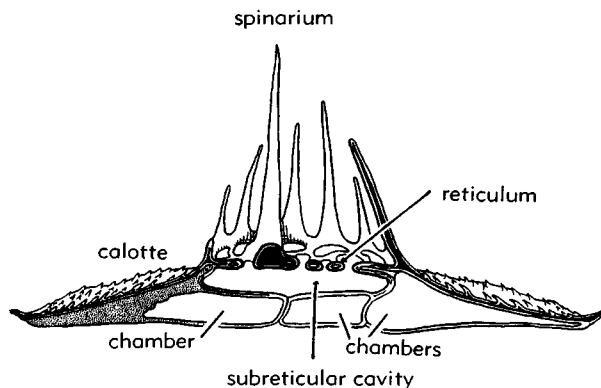

FIG. 72. Restoration of *Acanthastus*, in median section, ca. $\times 15$ (32).

UNRECOGNIZABLE GENERA

The following genera are not accepted as graptolites or are too imperfectly known for description and taxonomic placement.

Birastrites GEINITZ, 1866.

Buthograptus HALL, 1861.

Conograptus RUEDEMANN, 1947.

Ctenograptus NICHOLSON, 1876.

Dawsonia NICHOLSON, 1873.

Leveillites FOERSTE, 1923.

Megalograptus MILLER, 1874.

Nereograptus GEINITZ, 1852.

Phycograptus GURLEY, 1896.

Planktograptus YAKOVLEV, 1933.

Procyrtograptus POULSEN, 1943.

Protistograptus MCLEARN, 1915.

Protograptus MATTHEW, 1886.

Protovirgularia M'COY, 1850.

Stelechograptus RUEDEMANN, 1947.

Strophograptus RUEDEMANN, 1904.

Thamnograptus HALL, 1859.

Triaenograptus T.S.HALL, 1914.

Triplograptus RICHTER, 1871.

Undagraptus HEMMANN, 1951.

REFERENCES

This is only an abbreviated list containing what are judged to be the more important and generally useful references. An almost complete bibliography (with abstracts) to 1925 may be found in (17) and (5), and a list up to 1940 in (53).

Barrande, Joachim

- (1) 1850, *Graptolites de Bohême*: (Prague, vi + 74 p., 4 pl.

niho úst. Geologického, Sv. 19, p. 104-151 (in Eng.), pl. 1, fig. 1-14.

Benson, W. N., Keble, R. A., King, L. C., & McKee, J. T.

- (2) 1936, *Ordovician graptolites of North-West Nelson, N.Z.*: Trans. Roy. Soc. N.Z., v. 65, p. 357-382, fig. 1-6.

Bulman, O. M. B.

- (5) 1927-34, *Monograph of British dendroid graptolites*: pts. I-III. Palaeontograph. Soc., London, p. 1x + 92 p., 10 pl., 43 fig.
 (6) 1931, *South American graptolites*: Arkiv. f. Zool., Band 22A, no. 3, p. 1-111, pl. 1-12, fig. 1-41.
 (7) 1932-36, *On the graptolites prepared by Holm, I-VII*. Arkiv. f. Zool. 24A, no. 8, p. 1-46, pl. 1-9, fig. 1-18; no. 9, p. 1-29, pl. 1-9, fig. 1-12; Band 26A, no. 5, p. 1-52, pl. 1-9, fig. 1-19; Band 28A, no. 17, p. 1-107, pl. 1-4, fig. 1-30.
 (8) 1938, *Graptolithina*: in SCHINDEWOLF, O. H., Handb. der Paläozool., Borntraeger (Berlin), Band 2D, Lief. 2, p. 1-92, fig. 1-42.
 (9) 1944-47, *Monograph of Caradoc (Balclatchie) graptolites from limestones in Laggan*

Bouček, Bedřich

- (3) 1933, *Monographie der obersilurischen Graptolithen aus der Familie Cyrtograptidae*: Práce geol.-pal. úst. Karlovy univ., číslo 1, p. 1-84, pl. 1-7, fig. 1-19.

— & Münch, A.

- (4) 1952, *Central European Retiolites of the Upper Wenlock and Ludlow*: Sbornik Ústřed-