

The Trashumante Theatre

SARA P. SIMON

“Ay, mirad como pintaron el trailer de naranja. Como nuevecito quedó!” And the children who last February were admiring the orange trailer were right. It did look new compared to its previous dull gray appearance, the paint peeling off in spots. However, now that its budget had been renewed by the new mayor, the Trashumante traveling theatre was being renovated to continue bringing plays, puppet and variety shows to the people who live in the more modest outlying areas of this expanding industrial city of one million in north Mexico.

Some of the older *barrios* are in poor condition, but they do have their own civic centers consisting of an open air patio where seats can be placed, plus a library. Up to the present not one of these libraries has been known to contain any books, but they have tables and chairs which serve as a study hall for those students who lack the necessary space and privacy in their own homes. The outdoor stage is utilized primarily on legal holidays and Sundays (blue collar personnel still have a forty-eight hour work week here). The entertainment during authorized legal holidays will vary from patriotic declamations by selected school children to cliché-ridden orations by local politicians. Plays are sometimes presented, together with bands playing the regional *norteño* music of this area. Lately, in deference to the tastes of the younger generation, rock bands occasionally play. Magicians and puppet shows are occasionally offered. All this is provided by the city of Monterrey. On an ordinary Sunday afternoon a combination of any of the above types of entertainment may be offered.

Some of the plays, all one-acts, are for children only. They always end with the same admonition: “Never run away from home and always tell your parents where you are going.” This is not mere rhetoric. Children from these poorer areas (teen-agers in particular) do mysteriously disappear only to be found dead later, or are never heard from again.

Where are the entertainers from and how do they get their training? The musicians are usually professionals, members of the musicians' union. Both regional dances and the majority of the plays were performed by dance and

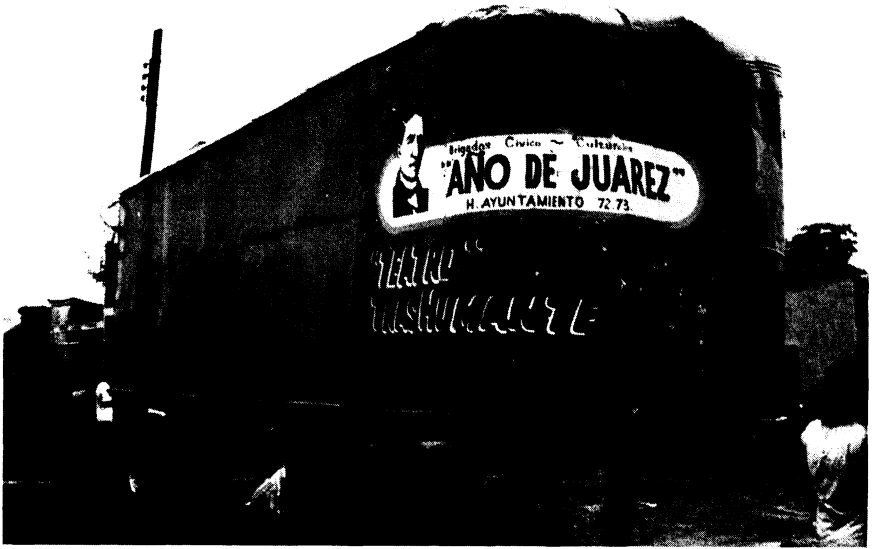

drama students from the Prestaciones Culturales division of the federally administered Bureau of Mexican Social Security.

The main function of this government bureau is the control, administration, and disbursement of compulsory medical, maternity and old age benefits. The Prestaciones Culturales division was created by the Social Security institution to give courses from four to nine daily "for the enrichment of the people both occupationally and culturally." At the end of each semester (December and June) exhibits of the pupils' work are placed in the main lobby of the building. The plays, dance and chorus recitals are given in the auditorium free of charge to an audience ranging from government officials to shoe-shine boys.

The dances and songs are authentically "folklorico." Their execution is based on instructions received from the research department located in Mexico City. Costumes representing each Mexican region as well as different historical eras are stored in the Prestaciones warehouse, also in Mexico City. Upon request, they are loaned to the dance and drama departments throughout the country. The plays have a national theme or one that is expected to appeal to a lower class audience. From three to seven shows are given. Upon request from the city government, the dances and plays are then presented in the more centrally located plazas and civic centers. If the programming committee of the Trashumante Theatre thinks that these shows will appeal to their audiences, they notify the proper municipal authorities. The message is then passed on to Prestaciones so that both dance and drama directors can make the necessary modifications in choreography and blocking for presentation on the stage at the trailer theatre.

The two plays most liked by Trashumante's audiences were: *Farsa y justicia del Corregidor*, by the early twentieth-century playwright, Alejandro Casona, and the French farce, *Monsieur Badin*, by Georges Coutelade. The former received the heaviest applause when presented for the inauguration of the theatre on

May 1, 1971. This date is the legal Labor Day here when everything is closed and even the humblest worker does not work. Much of the audience is from rural areas where far more serious perversions of justice than the ones so ironically expressed in this hilarious farce, still do occur.

In Casona's play, one sentence meted out by the judge, for charges brought against his district attorney friend, is to order the latter to break three of the plaintiff's ribs; but only the ones corresponding to the first three previously broken by the district attorney. The latter is also ordered to re-impregnate another plaintiff whom he had frightened into miscarrying. After hearing similar "justices" meted out to the subsequent plaintiffs, the last chooses not to press

OUTSIDE VIEWS OF THEATRE (Closed)

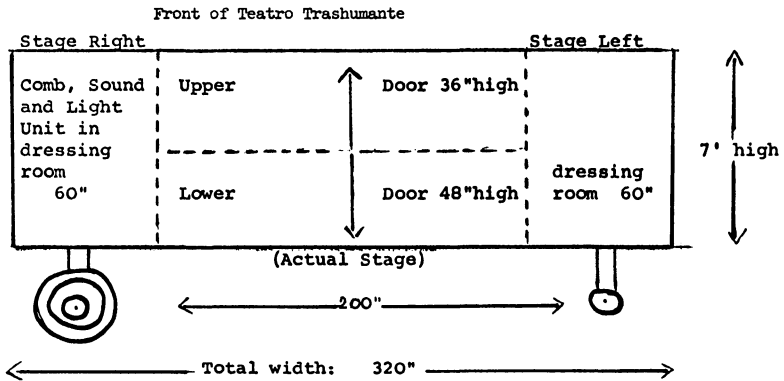

Rear of Teatro Trashumante

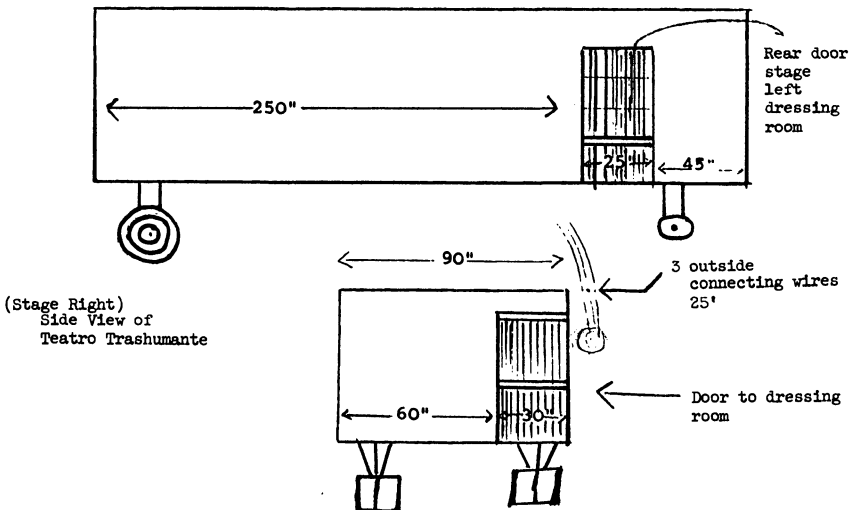

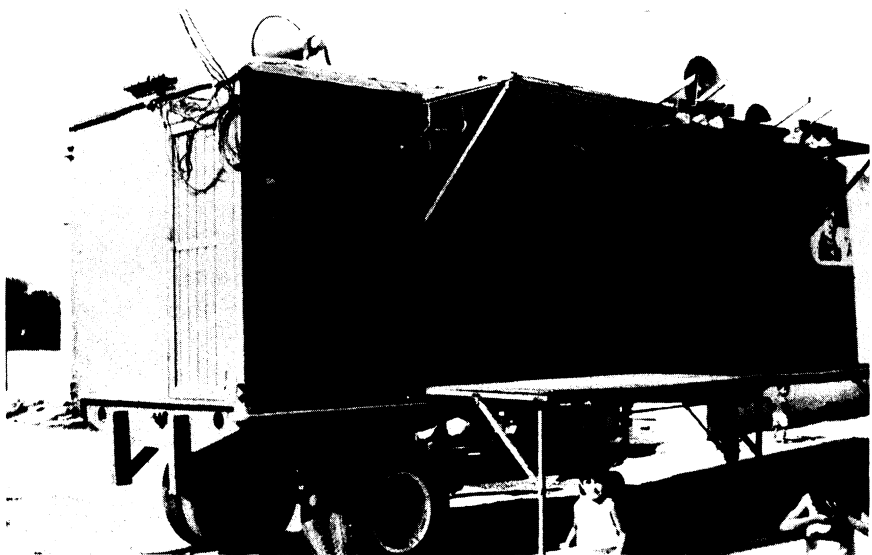

charges but dashes out behind the others, all of whom are running away as rapidly as possible.

Monsieur Badin deals with an inveterate but inept liar whose ridiculous alibis for his continued absences bring smiles of recognition to some of the audience. However, when he realizes the futility of continuing to lie and sincerely expresses the real reason for his absenteeism—he cannot face the meaningless and monotonous tasks assigned him day after day—many in the audience are no longer smiling. They too are in the same situation.

The director of both plays was René Silva. The cast for *Farsa y justicia* . . . was made up of pupils in his Prestaciones Culturales course. However by the time Badin's play was presented in October of the same year, the director was able to draw his cast from the workers of a local factory that had hired him to give drama lessons. Since Prestaciones Culturales salaries for all its teachers are excellent, those teaching dramatics have had previous experience as actors, directors or both. Some manage quite well on their Prestaciones salaries combined with radio and television engagements. Other teachers will have routine 9-5 jobs, but express themselves creatively through these classes whose students are usually factory and office workers.

The Trashumante's "longest run" and largest audience (100,000) was at the Home Fair held in Parque España. This twelve acre park, built and donated by the owner of a nearby smelter, is located in a working-class district. Its civic center is larger than those built by the city. The fair was held in August and September of 1971 and lasted forty-two days. Unlike other audiences, this one was from all economic and social classes who were interested in buying reasonably priced handicraft articles directly from the artisans themselves.

Trashumante audiences at the fair still preferred their own regional *norteño* music particularly when presented to a capacity audience on Mexican Inde-

pendence Day, September 16th. The musicians wore *charro* costumes: black velvet trousers, matching bolero jacket, and frilled white shirt. Their broad-brimmed black felt hats were sequined in red, white and green, the colors of the Mexican flag. The songstress' full-length, wide-skirted *norteño* costume was made up of the same three colors.

On that day there were more food vendors than usual, with menus varying from tacos to a four-course meal. The male diners who were sitting closest to the musicians let out *gritos*, raucous by even *norteño* standards. The *grito*, which sounds like a cross between a swiss yodel and a coyote's yelp, is given three consecutive times at the end of the first *norteño* stanza by any and every male listener present. Even during week night performances at the fair the shouts of the taco vendors were so overwhelming that the actors had to resort to lip-reading in order not to miss their cues. But they realized that they were one of the minor attractions at the fair; the fair-goers were far more interested in food and trinkets than in theatre.

The idea of the Trashumante ambulatory theatre was originated by Manuel Treviño. (The Trashumantes were a nomadic tribe in central Mexico who disappeared after the Spanish conquest.) While a law student at the state university, Treviño took drama courses and did some amateur acting. He is the 1972-73 director of the recently formed Department of Civic and Cultural affairs. One of his assistants handles the activities of the theatre. In 1970, just after he had been appointed to his previous post as Subdirector of the Municipal Public Relations and Press Department, Treviño read an article in an Oklahoma newspaper which described how one of the counties had converted an old trailer truck into a small theatre unit. Hauled into the more remote areas by a regulation

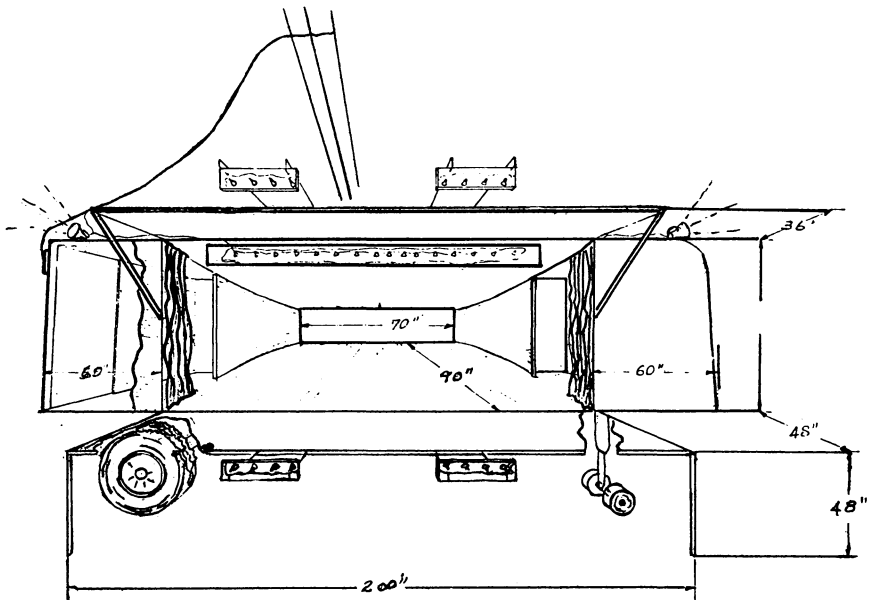

truck unit, it took both theatre and variety shows to the residents. He and René Silva located an abandoned trailer measuring twenty-seven feet long by seven and one half feet wide, quite similar in square feet stage area to several small theatres here. Treviño consulted his superiors about having an ambulatory theatre. They not only authorized him to purchase the trailer but also offered him the services of the city's electricity and carpentry departments.

The trailer was turned into a completely equipped theatre at a cost of ten thousand pesos (eight hundred dollars). The actual width and depth of the stage area inside the trailer when it is closed are seventeen by seven and one half feet. However, when it is opened, the ceiling depth increases to ten and one half feet and the floor depth of the stage to eleven and one half. This is because carpenters, working under Silva's supervision, ingeniously cut through the seven-foot-high front wall (i.e., the one facing the audience when the trailer is closed) so that the upper part of the wall ended up with a height of three feet; the lower with a height of four. When the wall separates in order to open for a performance, the upper part is supported by the two folding braces on either side; the lower by three automobile jacks, placed equidistantly underneath. When the *Trashumante* is not in use, the front wall always remains closed, not only for protection against inclement weather but against vandalism as well since it also functions as a storage box for the cycloramas and the sound and light units.

The three-piece cyclorama sets have recently been repainted in a light blue that matches the ceiling and floor of the stage. The central cyc is stationary and is seventy inches wide. The two slightly concave side cycs are moveable and measure seventy-eight inches each. However, the latter come within twenty-eight inches of the front edge of the ninety inch ara. The remaining space on both sides has curtains which lead into two small areas which, equipped with miniature tables, chair and mirrors, are used as dressing rooms. The two side cycs are both curved and moveable to permit a larger or smaller dressing area according to the type of performance. For example, with a six piece orchestra whose musicians come already costumed, but whose instruments are bulky, the side cycs are pushed out against the walls of the trailer itself. The small dressing room furnishings are placed outside until the performance is over. However, sufficient space is always left in the stage right dressing room for the one person needed to operate the sound and light units. Both dressing rooms can be entered through two doors built especially for that purpose.

The curtains also serve as exits should the script so require. Also, should additional exits be necessary, the side cycs are moved forward to cover the curtains partially. The resulting gaps between the two side cycs and center one yield two more exits. A problem does occur when the script calls for a quick exit and re-entry, if the exits are located on opposite sides. The actor has to dash out of one door, down some portable steps, over to the opposite entrance, and then up again. Plans are underway to attach a half-yard platform to the entire width of the trailer's outside rear wall to facilitate a quick re-entry.

The sound units consist of three amplifiers. The two facing the audience are placed at the front edge of roof, stage left and center. The third which faces the rear of the trailer is located stage right and is attached to the rear edge of the

roof. The light unit is wired so that there are separate circuits for white, blue, green, yellow and red. The electricity for both sound and light is received from three wires, twenty five feet long. They are located directly beneath the light board, and can be connected to any nearby electric pole or wire. René Silva maintains that the entire setting-up procedure (including the connection of the outside wire) can be done in ten minutes.

Since the Trashumante's re-opening in February, 1972, badly needed educational programs have been offered. Doctors, artists, and hair specialists have used slides to give instruction in basic hygiene and sanitation. Educational films on agricultural topics such as soil conservation and methods of increasing orchard yields are shown. Many of those who live in the *barrios*, because of their low earning capacity, may eventually return to their ranchos permanently or during the planting and harvesting time. It is hoped that they will put their new "know-how" not only to use for themselves, but will also pass it on to those who have never left their *ranchos*.

During the spring and summer of 1972, taking advantage of the longer daylight hours, the Trashumante also became a lending library. Hours were from 4-8 every Saturday and the borrowers had to read their books right near the trailer, returning them promptly at eight. Those on loan from the Municipal library are very elementary geography and history books. Those donated by the United States Information Service are in comic book form and invariably describe important historical deeds and personages in the U.S.A.

The most creative effort made to date by the programmers of the theatre is one in which a local artist, standing on the stage and using his easel, gives drawing lessons to children. Here the hours of instruction are determined by the families themselves, since all children must be accompanied by an adult. A social worker goes to each home in the *barrio* and obtains the preferred hours from those who are interested. She then transmits the information to the program committee. After a consensus has been reached, several days before, a sound truck goes through the area and announces what time the classes will take place. When the children arrive they are supplied with materials and the lesson begins. It should be taken into consideration that it is only the most ambitious of these marginal families that will make the effort to bring their children for instruction in such a "non-profit" activity. Or perhaps they hope that one day their child will become a famous national architect. And perhaps when interviewed about his childhood he will reply: "It all began with that ambulating truck; the Teatro Trashumante." Who knows?

Monterrey, Mexico